

## Presostatos diferenciales, tipos MP 54, 55 y 55A

### Introducción



Los presostatos diferenciales de aceite MP 54 y MP 55 se utilizan como interruptores de seguridad para proteger compresores de refrigeración contra presiones de aceite de lubricación insuficientes. En el caso de fallo de la presión de aceite, el presostato diferencial parará el compresor después de transcurrir cierto tiempo. Los MP 54 y 55 se utilizan en sistemas de refrigeración con refrigerantes fluorados.

El MP 55 A se utiliza en sistemas de refrigeración con R 717 (NH<sub>3</sub>), pero también se puede utilizar en sistemas con refrigerantes fluorados. El MP 54 tiene un diferencial de presión fijo e incorpora un relé temporizador térmico con ajuste fijo del tiempo de disparo. Los MP 55 y 55A tienen un diferencial de presión ajustable y pueden suministrarse con y sin relé temporizador térmico.

### Características

- *Amplia gama de regulación:* Pueden utilizarse en instalaciones de congelación, refrigeración y aire acondicionado.
- *Pueden utilizarse para todos los refrigerantes fluorados normales.*
- *Conexiones eléctricas en la parte frontal del aparato.*
- *Adecuados para corriente alterna y continua.*
- *Entrada de cable roscada para cables de 6 a 14 mm de diámetro*
- *Diferencial de conmutación pequeña*
- *Cumple con los requisitos de EN 60947*

### Homologaciones

M DEMKO, Dinamarca  
 O NEMKO, Noruega  
 W FIMKO, Finlandia  
 DSRK, Deutsche-Schiffs-Revision und -Klassifikation, Alemania  
 P Polski Rejestr Statków, Polonia  
 F Germanischer Lloyd, Alemania

EZU, República Checa  
 RINA, Italia  
 Marca CE según norma EN 60947-5

Bajo pedido, pueden suministrarse versiones homologadas por UL y CSA.

### Materiales en contacto con el medio

Tipo de unidad	Material
MP 54 MP 55	Acero inoxidable 19/11, n° 1.4306 según DIN 17440 Chapa de acero estirada, n° 1.0338 según DIN 1624 Acero para herramientas n° 1.0718 según DIN 1651
MP 55A	Acero inoxidable 19/11, n° 1.4306 según DIN 17440 Chapa de acero estirada, n° 1.0338 según DIN 1624 Acero para herramientas n° 1.0401 según DIN 1652

## Presostatos diferenciales, tipos MP 54, 55 y 55A

### Datos técnicos

*Tensión de control*  
230 V ó 115 V, c.a. o c.c.

*Temperatura máxima de los fuelles*  
100 °C

*Variación de tensión admisible*  
+10 → -15%

*Protección*  
IP 20 según IEC 529

*Presión de trabajo máxima*  
PB = 17 bar

*Cargas de los contactos*  
*Tipo A:*  
En los contactos M-S de salida del relé temporizador:  
AC15: 2 A, 250 V  
DC13: 0.2 A, 250 V

*Presión de prueba máxima*  
p' = 22 bar

*Tipo B sin relé temporizador*  
AC15: 0.1 A, 250 V  
DC13: 12 W, 125 V

*Compensación de temperatura*  
El relé temporizador tiene compensación de temperatura en la gama -40 a 60°C

*Tipo C sin relé temporizador*  
AC1: 10 A, 250 V  
AC3: 4 A, 250 V  
DC13: 12 W, 125 V

*Entrada de cable roscada*  
Pg 13.5

*Diámetro del cable*  
6 → 14 mm

### Pedidos

#### Para refrigerantes fluorados

Tipo	Diferencial $\Delta p$ bar	Diferencial de conmutación máxima $\Delta p$ bar	Gama de funcionamiento, lado de baja presión bar	Tiempo de apertura del relé temporizador s	Carga de los contactos (ver datos técnicos)	N° de código		
						Conexión		
						1/4" / 6 mm abocardada	1 m tubo capilar 1/4" soldar ODF	Conector por anillo de corte (cutting ring) 6 mm
MP 54	Fijo 0.65	0.2	-1 → +12	0 <sup>2)</sup>	B	<b>060B0297</b>		
	Fijo 0.65	0.2	-1 → +12	45	A	<b>060B0166</b>		
	Fijo 0.9	0.2	-1 → +12	60	A	<b>060B0167</b>		
	Fijo 0.65	0.2	-1 → +12	90	A	<b>060B0168</b>		
	Fijo 0.65	0.2	-1 → +12	120	A	<b>060B0169<sup>3)</sup></b>		
MP 55	0.3 → 4.5	0.2	-1 → +12	45	A	<b>060B0170</b>	<b>060B0133</b>	
	0.3 → 4.5	0.2	-1 → +12	60	A	<b>060B0171</b>	<b>060B0134</b>	<b>060B0188</b>
	0.3 → 4.5	0.2	-1 → +12	60	A	<b>060B0178<sup>1)</sup></b>		
	0.3 → 4.5	0.2	-1 → +12	90	A	<b>060B0172</b>		
	0.3 → 4.5	0.2	-1 → +12	120	A	<b>060B0173</b>	<b>060B0136</b>	
	0.3 → 4.5	0.2	-1 → +12	0 <sup>2)</sup>	B	<b>060B0299</b>		<b>060B0295</b>
	0.65 → 4.5	0.4	-1 → +12	0 <sup>2)</sup>	C	<b>060B0294<sup>4)</sup></b>		

#### Para refrigerantes fluorados y R 717 (NH<sub>3</sub>)

Tipo	Diferencial $\Delta p$ bar	Diferencial de conmutación máxima $\Delta p$ bar	Gama de funcionamiento, lado de baja presión bar	Tiempo de apertura del relé temporizador s	Carga de los contactos (ver datos técnicos)	N° de código	
						Conexión	
						∅ 6,5 / ∅ 10 mm manguito soldado	Conector por anillo de corte (cutting ring) 6 mm
MP 55A	0.3 → 4.5	0.2	-1 → +12	45	A	<b>060B0174</b>	<b>060B0182</b>
	0.3 → 4.5	0.2	-1 → +12	60	A	<b>060B0175</b>	<b>060B0183</b>
	0.3 → 4.5	0.2	-1 → +12	60	A	<b>060B0179<sup>1)</sup></b>	
	0.3 → 4.5	0.2	-1 → +12	90	A	<b>060B0176</b>	<b>060B0184</b>
	0.3 → 4.5	0.2	-1 → +12	120	A	<b>060B0177</b>	<b>060B0185</b>
	0.3 → 4.5	0.2	-1 → +12	0 <sup>2)</sup>	B	<b>060B0298<sup>2)</sup></b>	<b>060B0296</b>

<sup>1)</sup> Con luz piloto de funcionamiento que permanece encendida durante el funcionamiento normal.

**Nota:** si la luz piloto se apaga, el compresor no debe seguir funcionando un tiempo superior al de apertura del relé.

<sup>2)</sup> Las versiones sin relé temporizador son para aplicaciones en las que se necesita un relé temporizador externo, quizá con un tiempo de apertura distinto del especificado.

<sup>3)</sup> El 60B069 cumple las especificaciones Copeland. Pueden suministrarse versiones homologadas por UL.

<sup>4)</sup> Homologado según la norma EN 6097-4, -5.

## Differential pressure controls, type MP 54, 55 and 55A

### Design

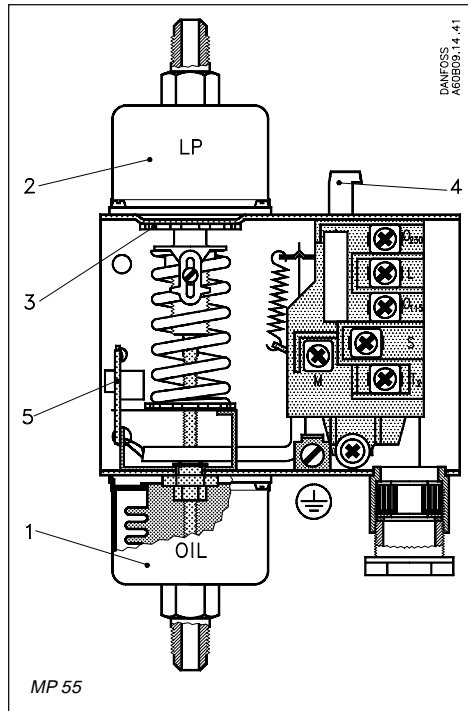

1. Connection to pressure side of lubrication system, OIL
2. Connection to suction side of refrigeration plant, LP
3. Setting disc
4. Reset button
5. Test device

The operation of the pressure control is conditional only on the differential pressure, i.e. the difference in pressure between the two counteracting bellows, whereas it is independent of the absolute pressure acting on both bellows.

The MP 55 and 55A can be set for different differential pressures by the setting disc (3). The set differential pressure can be read from the internal scale.

The MP 54 has a fixed differential and has no pressure setting disc. The factory-set differential pressure is stamped on the front plate of the control.

### Terminology

#### Differential range

The pressure difference between LP and OIL connections within which the control can be set to operate.

#### Scale reading

The differential between the oil pump pressure and the pressure in the crankcase that exists at the moment the contact system cuts in current to the time relay on falling oil pressure.

#### Operating range

The pressure range on the LP connection within which the control can operate.

#### Contact differential

The pressure rise above the set differential pressure (scale reading) necessary to cut off current to the time relay.

#### Release time

The period for which the differential pressure control allows the compressor to run with too low an oil pressure during start-up and operation.

### Function

If there is no oil pressure on starting, or if the oil pressure falls below the set pressure during operation, the compressor will stop after the release time has elapsed. The electrical circuit is divided into two completely separate circuits, a safety circuit and an operational circuit.

The timer (e) in the safety circuit is activated when the effective lubricating oil pressure, *the oil differential pressure* (the difference between the oil pump pressure and suction pressure), is lower than the set value.

The timer is deactivated when the oil differential pressure is more than the set value plus the contact differential.

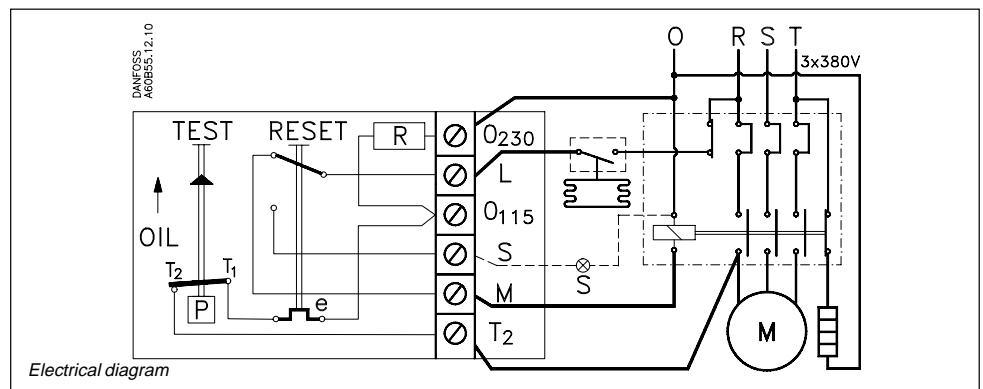

## Differential pressure controls, type MP 54, 55 and 55A

### Function (continued)

The two diagrams below explain the terms "oil differential pressure" and "contact differential", both have to be considered when using oil differential pressure controls.

The first diagram shows the function of the differential control during start; the second shows the function of the control during operation.

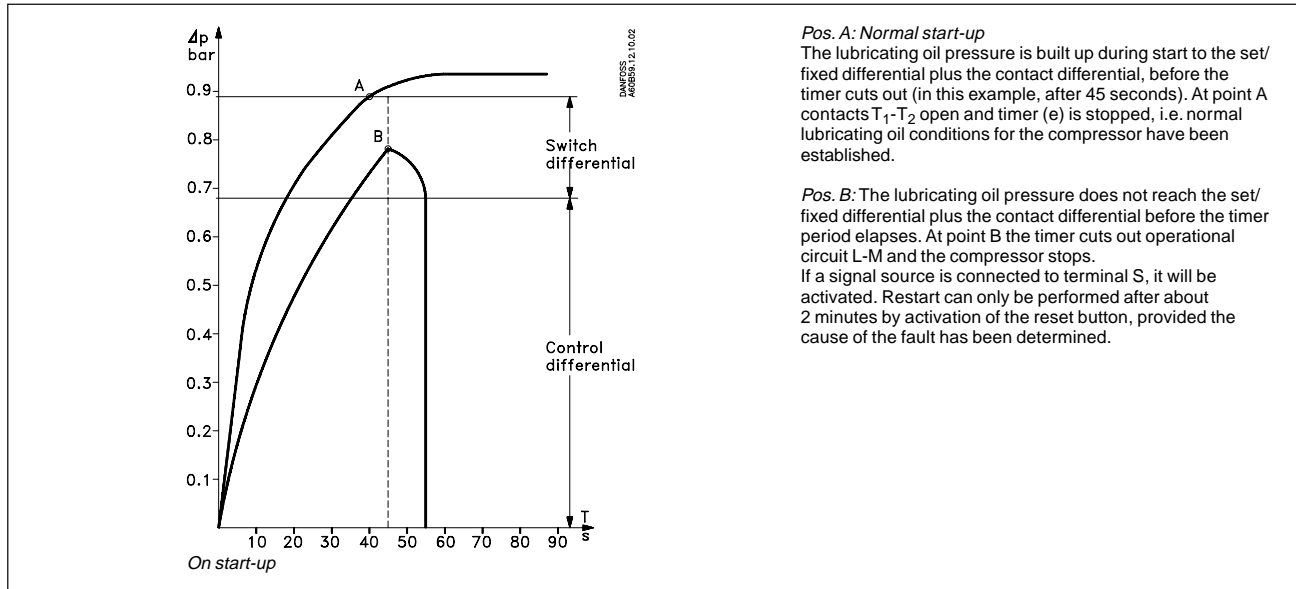

#### Pos. A: Normal start-up

The lubricating oil pressure is built up during start to the set/ fixed differential plus the contact differential, before the timer cuts out (in this example, after 45 seconds). At point A contacts  $T_1$ - $T_2$  open and timer (e) is stopped, i.e. normal lubricating oil conditions for the compressor have been established.

**Pos. B:** The lubricating oil pressure does not reach the set/ fixed differential plus the contact differential before the timer period elapses. At point B the timer cuts out operational circuit L-M and the compressor stops.

If a signal source is connected to terminal S, it will be activated. Restart can only be performed after about 2 minutes by activation of the reset button, provided the cause of the fault has been determined.

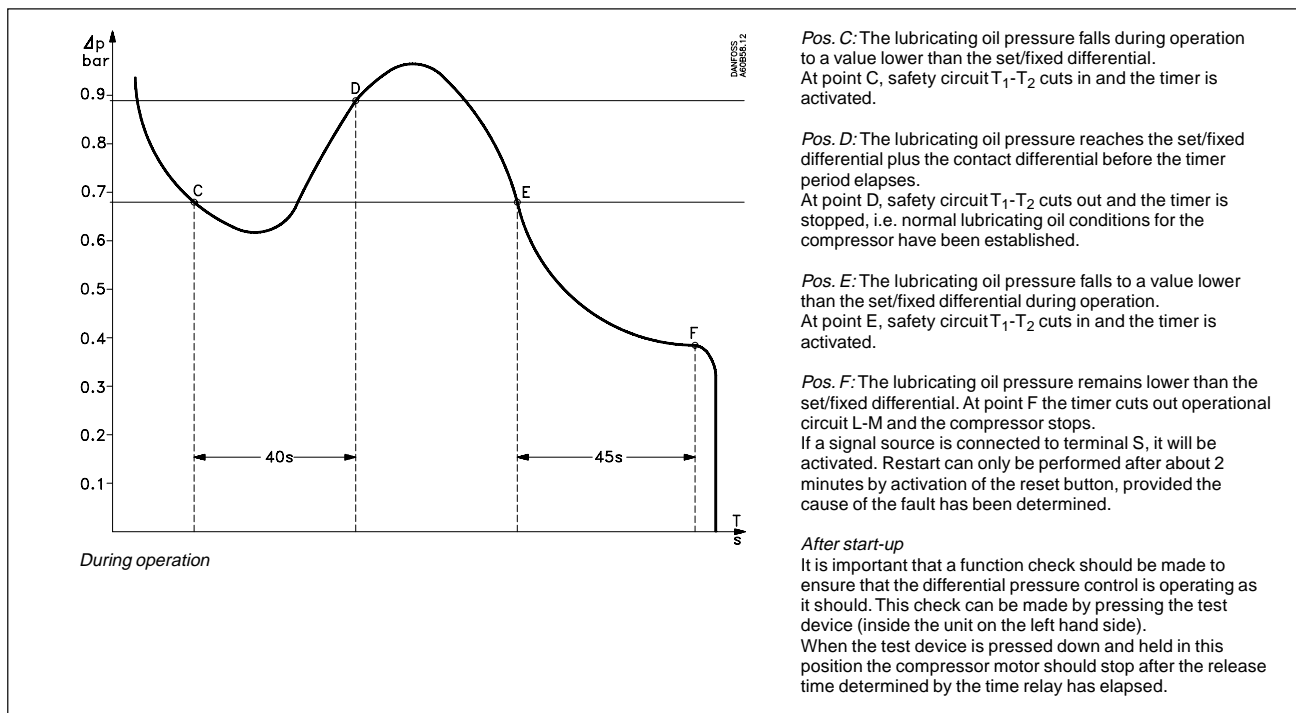

**Pos. C:** The lubricating oil pressure falls during operation to a value lower than the set/ fixed differential. At point C, safety circuit  $T_1$ - $T_2$  cuts in and the timer is activated.

**Pos. D:** The lubricating oil pressure reaches the set/ fixed differential plus the contact differential before the timer period elapses. At point D, safety circuit  $T_1$ - $T_2$  cuts out and the timer is stopped, i.e. normal lubricating oil conditions for the compressor have been established.

**Pos. E:** The lubricating oil pressure falls to a value lower than the set/ fixed differential during operation. At point E, safety circuit  $T_1$ - $T_2$  cuts in and the timer is activated.

**Pos. F:** The lubricating oil pressure remains lower than the set/ fixed differential. At point F the timer cuts out operational circuit L-M and the compressor stops. If a signal source is connected to terminal S, it will be activated. Restart can only be performed after about 2 minutes by activation of the reset button, provided the cause of the fault has been determined.

#### After start-up

It is important that a function check should be made to ensure that the differential pressure control is operating as it should. This check can be made by pressing the test device (inside the unit on the left hand side).

When the test device is pressed down and held in this position the compressor motor should stop after the release time determined by the time relay has elapsed.

Differential pressure controls, type MP 54, 55 and 55A

Dimensions and weight

