



RS300P Series

Robertshaw[®]

Premier 7-Day Programmable Thermostats

**Standard (Gas/Electric/Oil)
up to 2 Heat / 2 Cool**

**Heat Pump (Standard and Dual Fuel)
up to 3-Heat / 2-Cool**

Advanced Remote Bus with up to

**10 Remote Sensors; up to 6 Indoor,
1 Outdoor, and 3 Auxiliary**

GENERAL DESCRIPTION:

The RS300P Premier Programmable series of thermostats from Robertshaw are designed for new and replacement commercial or residential applications. The RS300P family has a beautiful new blue backlight and secondary display for the remote sensor bus. The RS300P family thermostats are direct replacements for the Robertshaw 300 series programmable products. They can be configured to control conventional HVAC equipment or heat pump equipment with both traditional and dual fuel heat pumps. The pushbuttons on the thermostat can be locked to give restricted override capabilities, and the optional Occupancy Sensor enables automatic energy savings. The advanced remote sensor bus allows up to 6 indoor remote sensors, an outdoor sensor, and up to 3 auxiliary sensors for needs such as supply air, return air, water temperature, walk-in freezers and refrigerators, and any other temperature monitoring desired.

Model	Equipment	Replaces
RS321P	2H/1C – Gas, Elec, Oil, Heat Pump	300-225, 300-226

STANDARD FEATURES:

- 7-Day Programmable, 5-2 Day Programmable or Manual Operation
- Auto Heat/Cool Changeover, Heating Only or Cooling Only Control
- Intuitive Setup Menu for Easy Configuration of Options
- Fan Selector for Automatic, Continuous or Recirculation Fan Operation
- Adjustable Fan Purge Timer to Use All Conditioned Air at the End of a Heating or Cooling Call
- Adjustable Min/Max Heating and Cooling Setpoint Limits
- Room Sensor and Remote Sensor Calibration Offset
- Commercial Lockout Mode with adjustable 0 to 24 Hour Override in 10min Increments
- Resume Button for Cancelling Commercial Override
- +/- 3°F (1°C) or +/-5°F (2°C) Restricted Temperature Adjustment in Commercial Lockout Mode
- 2 Occupied (Day-Cool & Day-Heat) and 2 Unoccupied (Night-Cool & Night-Heat) Setpoints
- Adjustable Balance Points for Heat Pump Compressor and Aux Heat Lockout when Used with Outdoor Sensor
- Selectable Fahrenheit or Celsius Display
- Lockable Access Cover
- HVAC equipment control using dry contact relays
- Two Digital Inputs with LEDs: LED1 (Green - Filter) and LED2 (Yellow – Fault) with or without LCD icon indications
- LED3 (Red - Emergency Heat; HP Operation Only)
- Setback Input for Use as Occupied/Unoccupied Trigger with Optional Occupancy Sensors (Ceiling and Wall Mount)
- Advanced Remote Sensor Bus Sensors allow up to 6 Indoor, plus Outdoor, Aux1, Aux2, and Aux3 (think supply air, return air... all on a 3-wire bus)
- Random Restart on power up randomly staggers restart of HVAC system after a power outage to minimize peak in-rush current for any installation
- Economizer Control on RS332PE and RS332PEH
- Humidity Control on RS332PEH

SPECIFICATIONS:

Rated Voltage:	20V to 30VAC, 24VAC nominal
Rated A.C. / D.C. Current:	0.05 to 0.75 AC / 0.0 to 0.75 DC Amp continuous, per output, surges to 3 Amps max.
Control Range:	Heating: 38 to 88°F (6 to 30°C) in 1° steps Cooling: 60 to 108°F (16 to 40°C) in 1° steps
Thermostat Sensing Range:	20 to 124°F (0 to 48°C) Control Accuracy: +/-1°F @ 68°F (0.5°C @ 20°C)
Minimum Deadband:	(between Heat and Cool) 2°F (1°C)
Dimensions:	4.5"H x 4"W x 1"D (114mm x 102mm x 26mm)
Thermostat LEDs:	Red – Emergency Heat, Yellow – Fault, Green – Filter
Equipment Terminations:	R - 24V switching voltage, W1 - Heat1 or Aux/Emer Heat, G - Fan, Y1-Compressor1, Y2 - Compressor2, O/W2 - Heat2 or Rev. Valve in Cooling, B-Rev. Valve in Heating
Power Terminations:	24V - remote power by removing jumper, 24V(c) - power common (from HVAC equipment)
Input Terminations:	LED1 (Green LED / Filter Icon), LED2 (Yellow LED / Fault Icon)
Occupancy Terminations:	CLK1 (+), CLK2 (-)
Remote Sensor Terminations:	RS+V - Power, RS2 - Return, RS1 - Data

WIRING DIAGRAMS:

**Not all terminals available on all models.
See thermostat manuals for specific wiring options.**

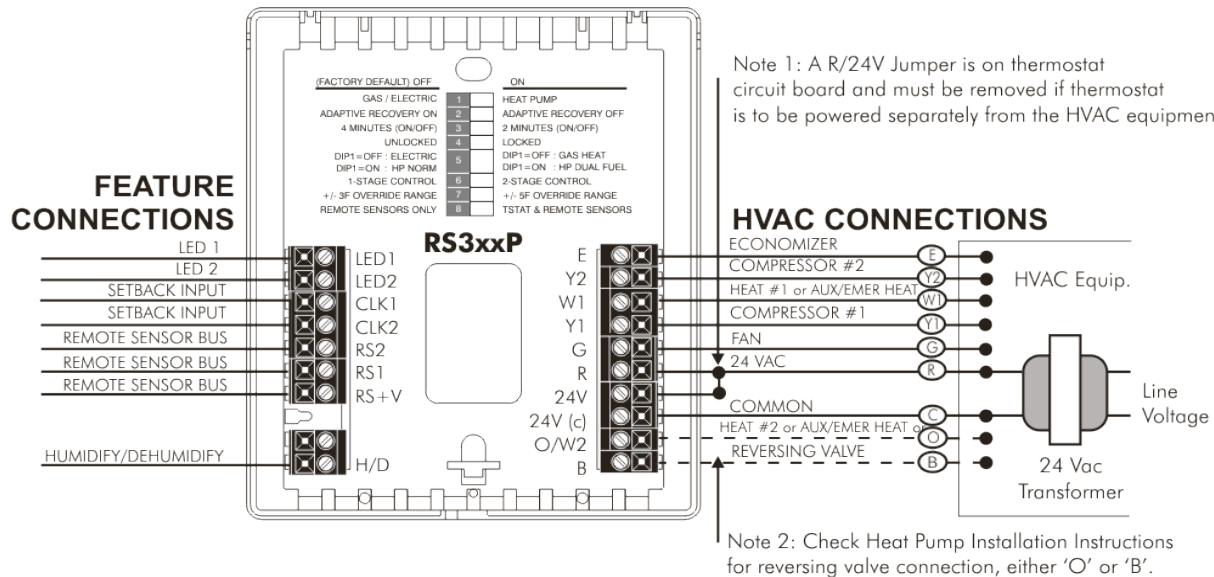

OUTPUT TERMINAL FUNCTIONS

LED1 Free light for status or function indication
LED2 Free light for status or function indication
CLK1 Dry contact closure input for setback
CLK2 Dry contact closure input for setback
RS2 Remote indoor, outdoor and/or wet
RS1 location sensor
RS+V Power for remote sensors
H/D Humidify/Dehumidify

E Energizes on an Economizer call
Y2 Energizes compressor for second stage cooling, or for heat pumps, either second stage heating or cooling
W1 Energizes heater for first stage heating, or for heat pumps, aux/emmer heat
Y1 Energizes compressor for first stage cooling, or for heat pumps, either first stage heating or cooling
G Energizes fan circuit with a call for heating or cooling
R Independent Switching Voltage from HVAC equip
24V 24Vac
24V(c) 24Vac Common
O/W2 Energizes heater for second stage heating, or for heat pumps, energizes the reversing valve in cooling mode



Customer Service (Americas) +1.800.304.6563
 Customer Service Facsimile +1.800.426.0804
 HVACCustomerService@robertshaw.com

For Technical Service
 Telephone +1.800.445.8299
 TechnicalService@robertshaw.com

Robertshaw® is a trademark of Robertshaw, its subsidiaries and/or affiliated companies. All other brands mentioned may be the trademarks of their respective owners.

www.robertshaw.com
 ©2020 Robertshaw
 02/20 – 150-2762