

Robertshaw®

RS3110

ECONOMY SERIES



ELECTRIC

GAS

OIL

HEAT PUMP

MILLIVOLT
RS3110 only

5 - 2 Day Programmable

RS3110 – 1 Heat / 1 Cool

COD. ANSAL 955630

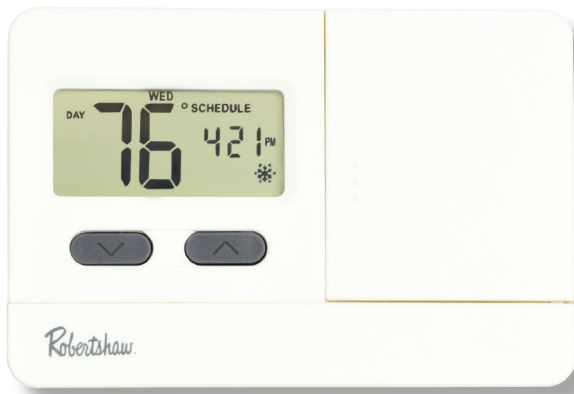

Affordable Comfort Control

The Robertshaw® RS3000 thermostat family is *Simply The Right Choice™* when it comes to programmable temperature control that can help reduce energy costs up to 25%.

With the comfort, convenience, and efficiency features that homeowners and contractors want, the RS3000 family provides custom program options in value-packed thermostats for an economical price.

- Simple touch button controls to set weekly programs for summer and winter.
- Automated temperature settings for increased heating/cooling comfort.
- Worry-free memory retention to maintain temperature settings even during power outages.

All RS3000 thermostats are fully compatible with all standard 24V AC heating and cooling systems. The RS3210 offers additional compatibility with single and multi-stage gas/electric furnaces and heat pump systems.

Add in easy installation, expert technical service, and quality you can depend on, and you have the Robertshaw RS3000 thermostat family – *Simply The Right Choice.*

Features and Benefits

5 - 2 Day Programming

Set the weekly program once with four time and temperature settings. The four set points are followed for five consecutive days. On the weekend, four different set points can be set for all day comfort.

Multi-Stage 2 Heat / 1 Cool – RS3210 only

Operates on both multi-stage gas/electric furnaces and heat pumps to reduce inventory needed.

New Improved Display

Makes viewing and setting the temperature easier.

Adjustable Temperature Differential

Maintains optimal customer comfort.

Worry-Free Memory Retention – RS3210 only

Maintains programmed parameters, even during power outages.

Filter Monitor

Provides notice when filters need changing.

Automatic Compressor Short Cycle Protection

Reduces wear and tear of HVAC equipment with this system safeguard.

Temporary Program Override

Allows for manual temperature adjustment.

Quick Wire Terminal Block

Uses sturdy wire clamps – no wrap-around of screws for fast and easy installation.

California Title
24 Compliant

2 Year
Limited
Warranty



Terminal Designations

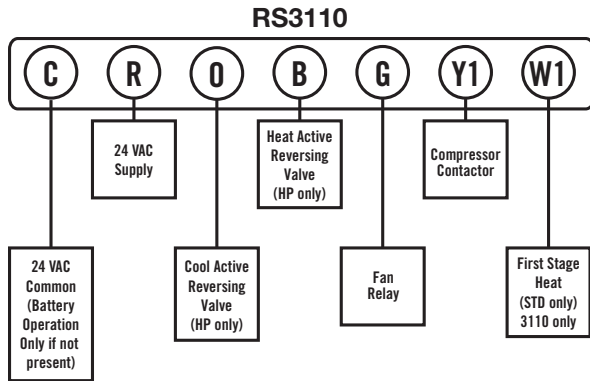

Technical Specifications

Product Weight	10.4 oz.
Electrical Rating	24V AC (18-30V AC) 1 amp maximum load per terminal 3 amp total maximum load (all terminals combined)
Temp. Control Range	45°F to 90°F (7°C to 32°C)
Accuracy	± 1°F (± 0.5°C)
Power	24V AC with battery back-up OR 3V DC battery powered

System Configurations **RS3110** – Single stage electric, gas, oil or millivolt heating or heating/cooling systems including single stage heat pump systems. Not to be used with split transformer systems or 3-wire Hydronic (Hot Water) Zone Heat 110/220 Volts.

RS3210 – Multi-stage electric, gas or oil heating or heating/cooling systems including multi-stage heat pump systems. Not to be used with split transformer systems or 3-wire Hydronic (Hot Water) Zone Heat 110/220 Volts.

Terminations **RS3110** – C, R, O, B, G, Y1, W1
RS3210 – C, R, O, B, G, Y1, W1, E/W1, W2, L

Replacement Chart

RS3110	
Robertshaw®	8600, 8601
Braeburn®	2000, 2010, 2000NC
Lux	TX500, TX500E
Honeywell	TH2110D
White-Rodgers	1F78-151

Verify specific application requirements before substitution.

Shipping Specifications

Individual Carton Dimensions	6.75" x 4.375" x 1.625"
Master Carton Quantity	6
Master Carton Dimensions	9.25" x 5.625" x 7.625"
Master Carton Weight	4.2 lbs.