

SPECIFICATION for APPROVAL

Reciprocating Compressor

MODEL: CMA062LHEG

Ansal

LG Electronics

2017.04.10

Approver

Design Manager

Remark

Please return one copy on your approval.

Please read this specification thoroughly before installation or operating.

Revision History

No	Date	Article	Description	Writer

Contents

1. Accessory List
2. Result of Check for Customer
3. Safety Precaution
4. Specification of Compressor
5. Technical Bulletin
6. Compressor Housing
7. PTC and OLP Assembly
8. Electrical Components Cover
9. PTC Starter
10. Overload Protector
11. Mounting Accessory
12. Transportation
13. Compressor Packing
14. Compressor Label

1. Accessory List

1.1 Electrical

Description	Q'ty	Supply From LG	Part No.	Specification
PTC	1	YES	6749C-0013E	QP2-33MC1
Overload Protector	1	YES	EAF61770702	4TM213SFB
Cover PTC	1	YES	3550CT0008B	JUSU
Fixing Screw	1	YES	FAB30638601	-

1.2 Mounting

Description	Q'ty	Supply From LG	Part No.	Remark
Earth Screw	1	YES	FAB30047001	-
Seat Rubber	4	YES	5166CT0002A	-
Sleeve Bolt	4	YES	4816CT0001D	-
Bolt Assembly	4	YES	1BZZCT0006A	-
Nut Common	4	YES	1NZZCT0002A	-

1.3 Others

Description	Q'ty	Charging From LG	Specification	Remark
Lubricant Oil	150cc	YES	8cst	

Customer Approval: _____ (signature)

2. Result of Check for Customer

2.1 Information of Cabinet

No.	Check Items	Result
1	Product model name	
2	Product type	<input type="checkbox"/> Refrigerator <input type="checkbox"/> Freezer <input type="checkbox"/> Water Dispenser <input type="checkbox"/> etc. ()
3	Cooling type, comp	<input type="checkbox"/> Direct <input type="checkbox"/> Indirect / <input type="checkbox"/> Fan <input checked="" type="checkbox"/> Natural
4	Nominal capacity	() liters
5	Refrigerant charging quantity	<input type="checkbox"/> R12 <input checked="" type="checkbox"/> R134a <input type="checkbox"/> R600a () grams
6	Running comp model	Model name : CMA062LHEG

*Please leave as they are, if you don't need check items.

2.2 Set Matching

No.	Check Items	Result	Remark
1	Starting : Be satisfied ?	Yes / No	
2	Energy consumption : Be satisfied ?	Yes / No	
3	Noise : Be satisfied ?	Yes / No	
4	Etc. mounting is satisfied ?	Yes / No	

*Please leave as they are, if you don't need check items.

2.3 Reliability

No.	Check Items	Result	Remark
1	Is the result good?	Yes / No	
2	Would you give us compressor test's sample after reliability test?	Yes / No	

*Please leave as they are, if you don't need check items.

3. Safety Precaution

IMPORTANT SAFETY INSTRUCTIONS

The following precautions is to prevent unexpected hazard.

▲ WARNING You can be killed or seriously injured if you don't follow instructions.

Service should be performed by trained personnel only.

Install the refrigerant, lubricant oil and electrical component (PTC, OLP, Capacitor and PTC Cover) specified by compressor manufacturer.

It can cause fire or electrical shock.

Connect the electrical wiring correctly in accordance with manufacturer's instruction.

It can cause fire or electrical shock.

Compressor must be grounded whenever power is supplied.

Do not use earth screw, except for ground.

It can cause electrical shock.

Before servicing, always remove the power plug from outlet.

It can cause electrical shock.

Before welding, always remove refrigerant in the compressor.

Do not operate compressor in the air or vacuum status.

It can cause explosion

Do not touch the compressor with bare hands during operation or after stoppage instantly.

It can cause get burnt.

SPECIFICATION OF COMPRESSOR

•**Model : CMA062LHEG**

•**Normal Voltage / Frequency : 220~240 V / 50Hz**

1.Application			4.Electrical Device		
Refrigerant	R134a	Low Back Pressure	<u>Starting Device Type</u>	PTC	
Evaporating temp-range	-35 °C ~ -31 °F	-5 °C ~ 23 °F	Model Name	QP2-33MC	
Expansion-Device	Capillary tube		Resistance	33 ohm	+/- 20 %
Compressor Cooling	Static		at	25 °C	77 °F
Operating Voltage	220~240 V	50 Hz	<u>Overload Protector</u>	OLP	
2.Normal Performance			Model Name	4TM213SFB	
Cooling Capacity	153.0 Kcal/h	-5 %	Opening Temp	130 °C	+/- 5 °C
	177.9 W/h	-5 %	Closing Temp	61 °C	+/- 9 °C
Power Consumption	122.0 W	+7 %	Ultimate Trip Current	1.62~2.19	A
EER	4.98 Btu/Wh	-5 %	Short Trip Current	6.7	A
COP	1.46 W/W	-5 %	<u>Running Capacitor</u>	uF	Vac
Current	0.88 A		<u>Starting Capacitor</u>	uF	Vac
Noise(ASHRAE)	39dB	Max 42dB	5. Motor		
* Test Condition	(ASHRAE)		<u>Starting Type</u>	RSIR	
Evaporating Temp	- 23.3 °C	- 9.9 °F	<u>Voltage/Frequency</u>	220~240 V	50 Hz
Condensing Temp	54.4 °C	129.9 °F	<u>Run Winding</u>	21.90 Ohm	+/- 5 %
Ambient Temp	32.2 °C	90.0 °F	at	75 °C	167.0 °F
Return Gas Temp	32.2 °C	90.0 °F	<u>Start Winding</u>	10.40 Ohm	+/- 10 %
Liquid Subcooled Temp	32.2 °C	90.0 °F	at	75 °C	167.0 °F
Test Voltage	220 V	50 Hz	<u>Lock Rotor Current</u>	10.2	A
3.Mechanical Data			6. Certification		
Displacement	6.2 cm ³	0.37 inch ³	VDE/CCC		
Bore	23.0 mm	0.92 inch	7. Remark		
Stroke	15.0 mm	0.60 inch			
Oil Charge	150 cc (cm ³)	+/-10 cc			
Lubricant type	Ester				
Viscosity	8cst				
Weight(with Oil)	7.60 Kg	16.7 lb			

Although these components have passed test for use with this compressor, LG assumes no Responsibility whatsoever for these or any other components sourced by the refrigerator manufacturer from third parties.

5. Technical Bulletin (Application Specification for R134a)

The life time of a compressor used in appliance is not only affected by the durability of compressor but also depended upon the operating conditions imposed on it by design on the refrigeration system it is used in. This bulletin covers the specification and usage limits for LG R134a low back pressure (LBP) compressor.

The limits and guidelines set forth in this publication should be observed.

Compressor operating range. The Compressor can operate within the limits of the outlined area. Outside these operating fields, the system cause early defects in the compressor.

The compressor defects caused by applications operating outside the outlined area will not be considered under the warranty. If the appliance be operated out of the operating range, it must be agreed with the supplier.

	Normal operation		Peak conditions at maximum load (at initial pull-down) (Area "A", "B" and "C" on chart)
	Stabilized condition (Area "A" on chart)	Transition running (Area "A" and "B" on chart)	
Discharge Pressure	17.1kgf/cm ² abs (equal to condensing temp. of 60°C)		21.6kgf/cm ² abs (equal to condensing temp. of 70°C)
Suction Pressure	0.68 to 2.49kgf/cm ² abs (equal to evap. temp. of -35°C to -5°C)	0.68 to 7.0kgf/cm ² abs	
Motor Winding Temp. "D-Tube" Temp.	Under 120 °C 1* (CMA, M*, L* / MS*53) : Under 110 °C, 2* (TS, CSB, NS* / MS*43 ↓) : Under 120 °C		Under 130 °C 1* / 2* : Under 120 °C / 130 °C

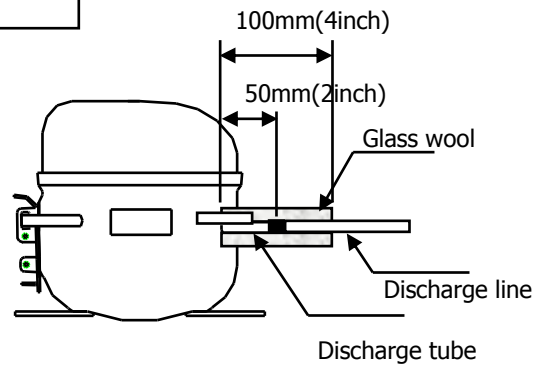
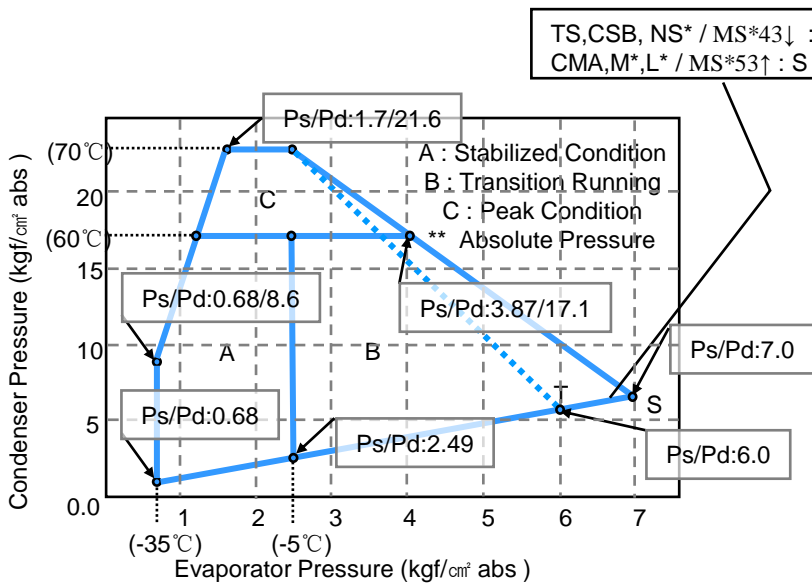

Locating the thermocouple for "D-Tube" Temperature determination

5. Technical Bulletin (Application Specification for R134a)

Application Specification for R134a

No	Item	Standard & Designation	Conditions & Remark
1	Refrigerant	R134a	-
2	Ambient temp.	-5 ~ 43 °C	Operating ambient temperature should be kept
3	Evaporation temp.	L.B.P : -35 ~ -5 °C (-31~23 °F)	Except for the short period such as pull-down tec.
4	Condensing temp.	60 °C (140 °F) max. 70 °C (158 °F) max.	In stabilized at ambient temp. 43 °C (110 °F), At the peak in pull-down in ambient temp. 43 °C (110 °F)
5	Equalized pressure at starting	Equalized pressure : • TS, CSB, NS* / MS*43↓ : 6.0kgf/cm ² abs or less •CMA, M* , L* / MS*53 : 7.0kgf/cm ² abs or less	Cabinet startability should be confirmed for a compressor dome temperature greater than 65 °C •Shell temperature : -5 to 65 °C •If exceed, must be verified the startability with set test.
6	Voltage range	-15% ~ +15% * rating	At the terminals of compressor
7	Cycle time	On time : 5 minutes or more Off time : 5 minutes or more	Recommended to start up at balanced Hi-Lo Pressures in 5 minutes after stand still.
8	Refrigerant charge	Below 200g	Minimize meeting cooling performance, start ability, temperature limits, pressures limits, pressures limits.
9	Evacuation levels	0.5 Torr max.	Evacuation should be done from both the high and low sides
10	Oil Moisture	25 ppm max.	-
11	System Moisture	150mg max.	In a refrigeration system, due to degradation of ester oil caused by moisture
12	Pressure rise at abnormal situation	35kgf/cm ² abs max.	Even in case of condenser fan-blocked.
13	Non-condensable gas	Total : 1%(Vol.) Max. Oxygen : 0.01%(Vol.) Max.	Against total inner volume of refrigeration system.
14	Degree of tilt	5 deg. Max.	On running. Compressor shall not be tilted more than 5 degrees in all direction.

5. Technical Bulletin (Application Specification for R134a)

Note :

1. Do not leave the Compressor with it's pinch plug open for more than about 15 minutes.
2. Purchased compressor with/without oil charged and sealed be used within 12months from the production date shown on the name plate.
3. Never run the Compressor with any air other than the refrigerant.
4. Never run the Compressor without refrigerant properly filled inside.
5. A dropped Compressor must not be used.
6. To avoid any contamination on the refrigerator assembly line, a dedicated charging station (refrigerant or oil) must be used.
7. All materials used in the process must be compatible with the R134a.
8. When vacuuming the whole cycle system, for air or hazardous gases not to contaminate the cycle, evacuate it sufficiently using the high efficient vacuum pump.
The refrigerant must be charged in state of compressor OFF.
9. Due to high flammability of R134a, refrigeration system welded securely not to occur leakage, and leakage test equipment exclusively designed for R134a application should be prepared separately.
Special dryer is needed when using .(for instance XH-7 or XH-9), Usually a 20% larger dryer is recommended.
10. Electrical accessories
 - *The compressor's electrical accessories should be used within specification and within their permissible ambient temperature
 - *Vinyl chloride and chloride compounds should not be used as a material for electrical terminal covers and electrical connections.
11. Brazing - Compatible materials and proper brazing techniques must be used to assure complete not oxidized joints, and to avoid flux, particles or dust from entering the sealed systems.
12. Motor protector

All accidents can not be prevented by motor protectors.

An earth terminal should be installed to prevent electrical accidents caused by the following factors.

 - wrong power source, - Wrong wiring - Wrong electrical parts
 - Operation in a system leak , - Operation under a vacuum condition,
 - Abnormal parts, Lightning damage
 - Corrective or oxidizing gaseous atmosphere , - Dust
 - Volatile or flammable gaseous atmosphere.

- Abnormal atmosphere pressure. Water or high humidity levels approximating dew point.
 - Salt water or salty mist, oils, chemicals agents and solvent.
- Especially, do not use polyvinyl chlorine (PVC) as an insulation material around the terminal connection to the PTC element as these may release chlorine when subject to higher temperatures, causing the PTC the malfunction.

13. Liquid back

Excessive liquid back in refrigeration system should be avoided to prevent an abnormal wear at a friction area by a cause of a lubrication malfunction. In addition, liquid back can cause damage to the crank shaft, calve plate and head gaskets, causing them to break.

14. In case of change in cycle construction or parts related to compressor or compressor specification without agreement of LGE.

Please notify that the responsibility for all case of problem issues is to the customer.

15-1. Materials compatible to R134a should be used in refrigeration system

15-2. Equipments for refrigerant charging and vacuuming exclusively designed for R134a application should be need.

15-3. Leakage test equipment exclusively designed for R134a application should be prepared separately.

15-4. Maximum water content in refrigeration system must not exceed 150mg.

15-5. When compressor is attached to refrigeration system, give attention to the following notices.

1) Nitrogen is charged and sealed before compressor is shipped.

A compressor should be handled carefully not to be unplugged or damage sealing caps during transportation or in warehouse.

2) Compressor with rubber cap removed must be attached to the cycle as soon as possible.

3) During deposition or transportation, keep compressors in upright position and be cautious not to drop it.

4) When compressor is attached to cycle, clean and ventilate the vicinity so that pollutants such as dust, steel tip or flux are not included.

5) Since the paint of compressor is made of epoxy polyamide resin, when the paint peels off, by accident repaint.

16. Protecting Reverse Operation

The Compressor must be operated by proper voltage in accordance with the frequency without reverse revolution condition. The reverse revolution condition can be avoided by just keeping right order of phase supplied power source.

6. Compressor Housing

Part	Name	ID	Thickness	Length	Bending
Pipe	Suction	6.54	0.7	46	Inner 45°, Up 0°
	Process	6.54	0.7	46	Inner 45°, Up 0°
	Discharge	5.0	0.85	37	Inner 20°, Up 0°

Height	171
---------------	------------

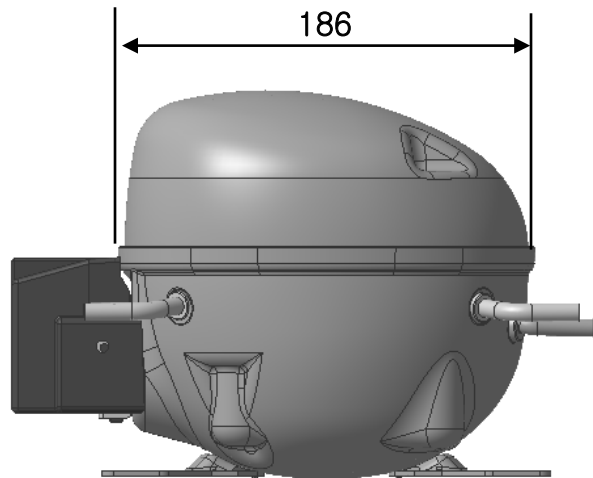
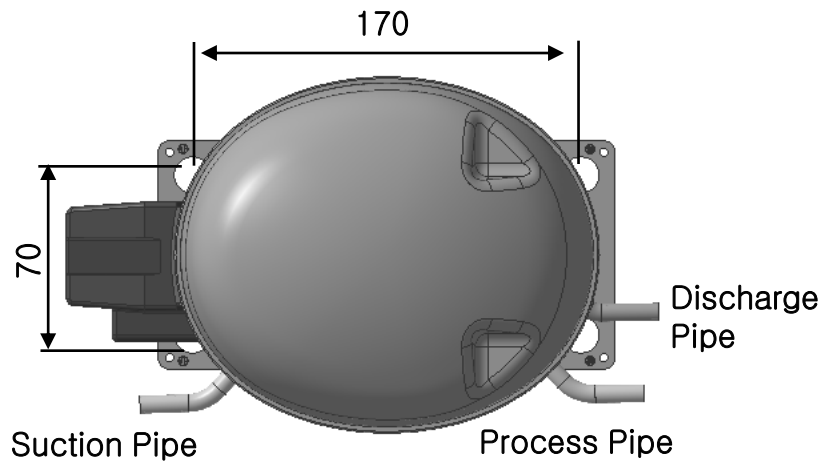
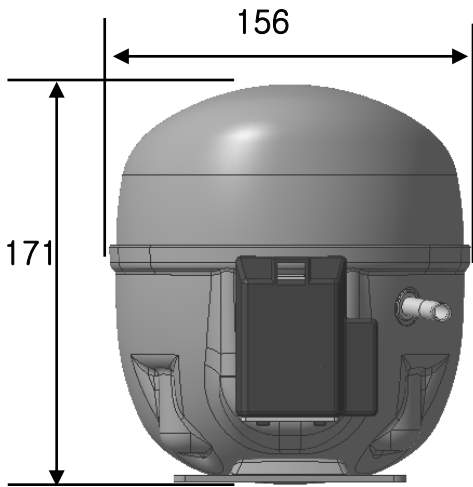

7. PTC and OLP Assembly

Exploded View

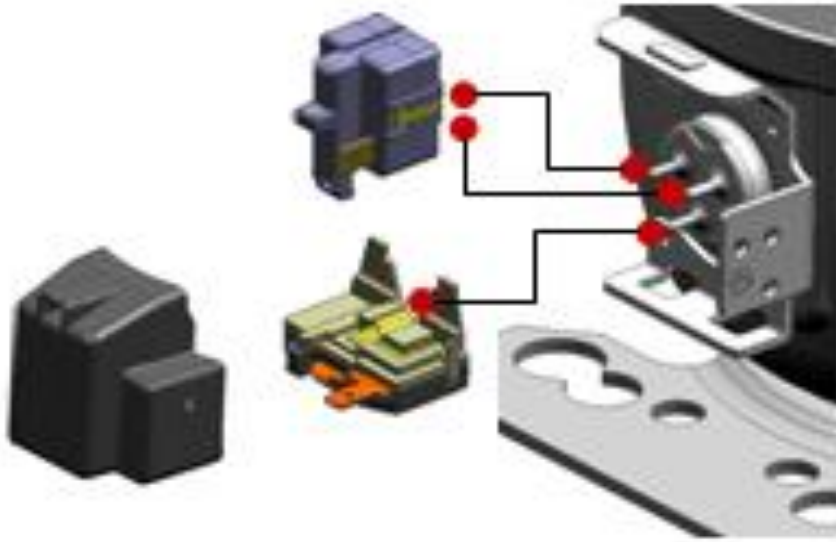

Wire Diagram

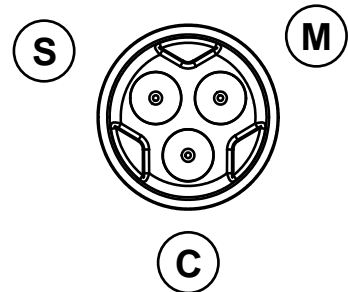
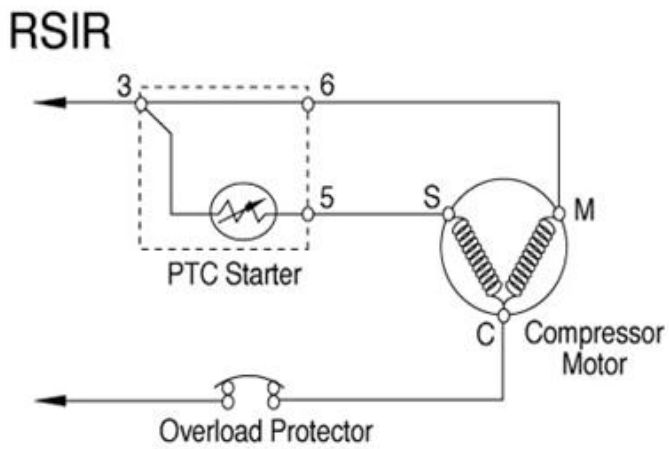

8. Electrical Components Cover

Specification	Cover PTC
Material	ABS

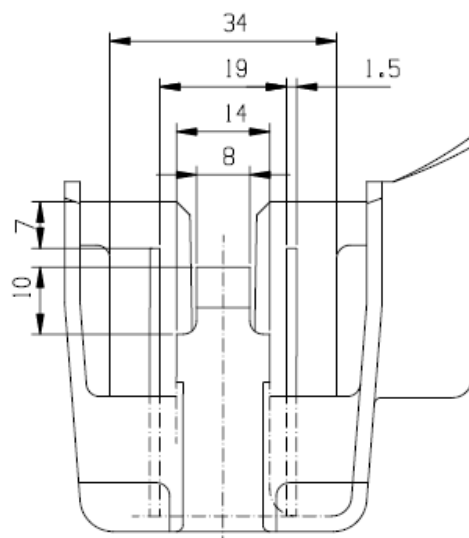
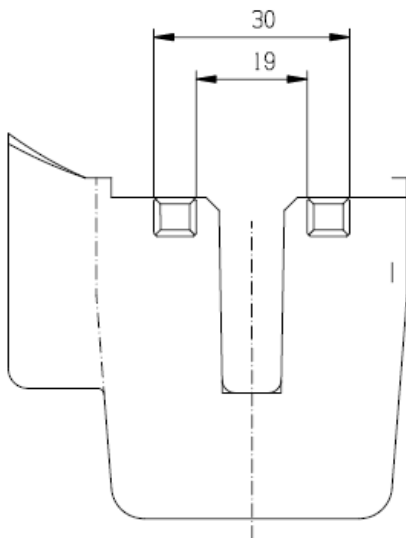
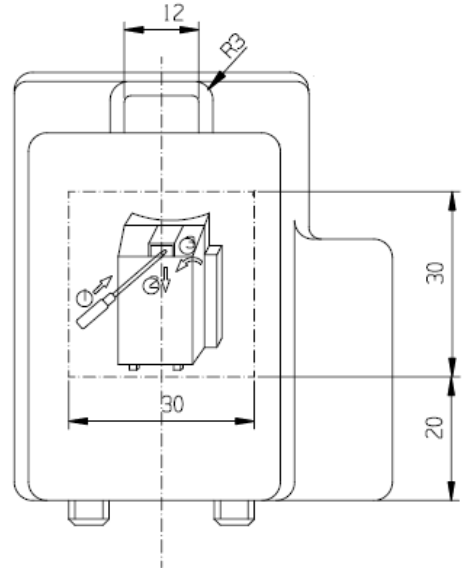
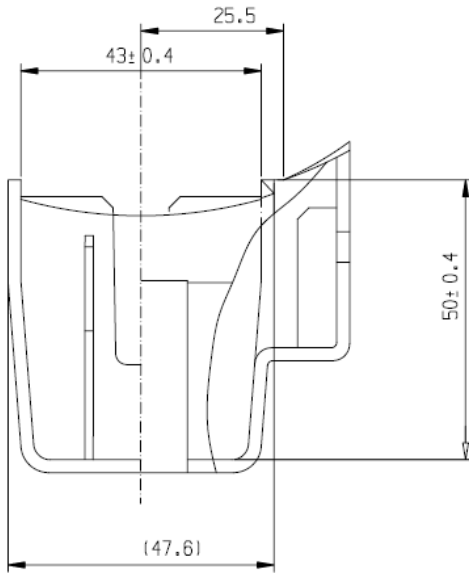

Fixing Screw

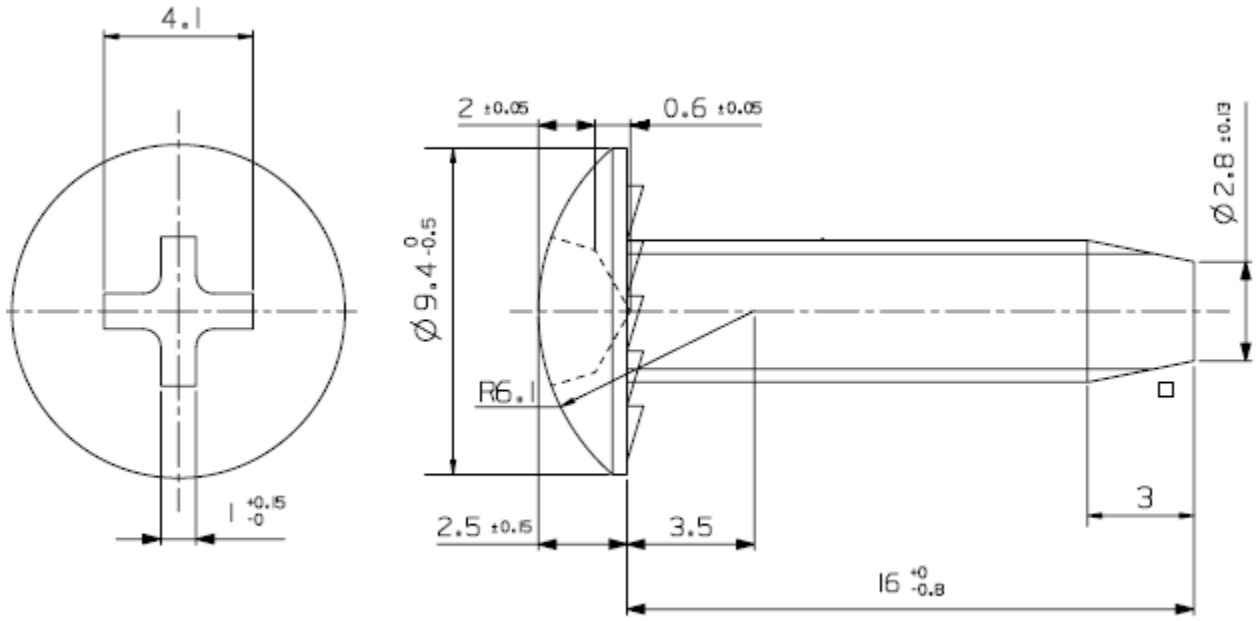

Earth Screw

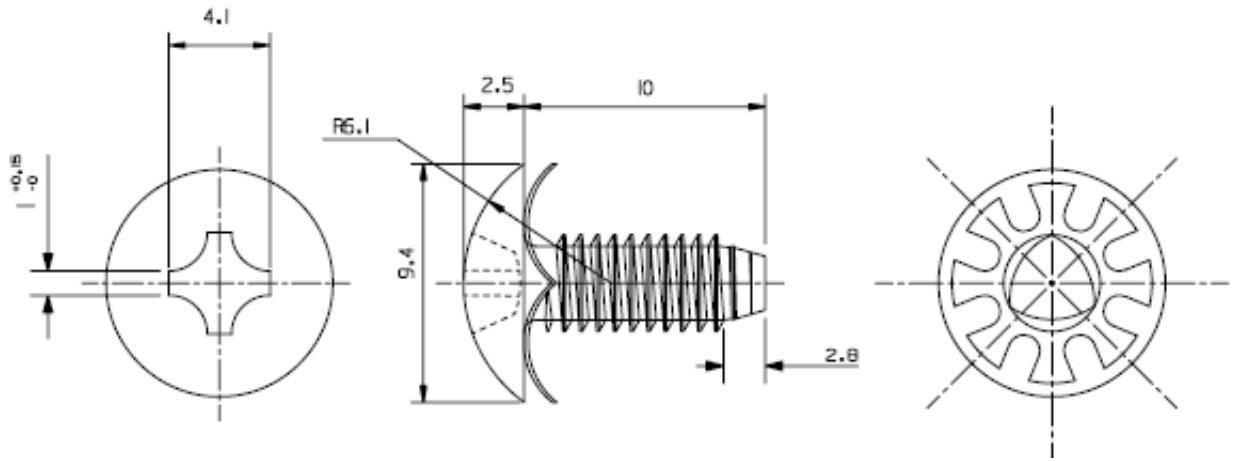

9. PTC Starter

Specification	QP2-33MC1
MAKER	STAR SHUAIER

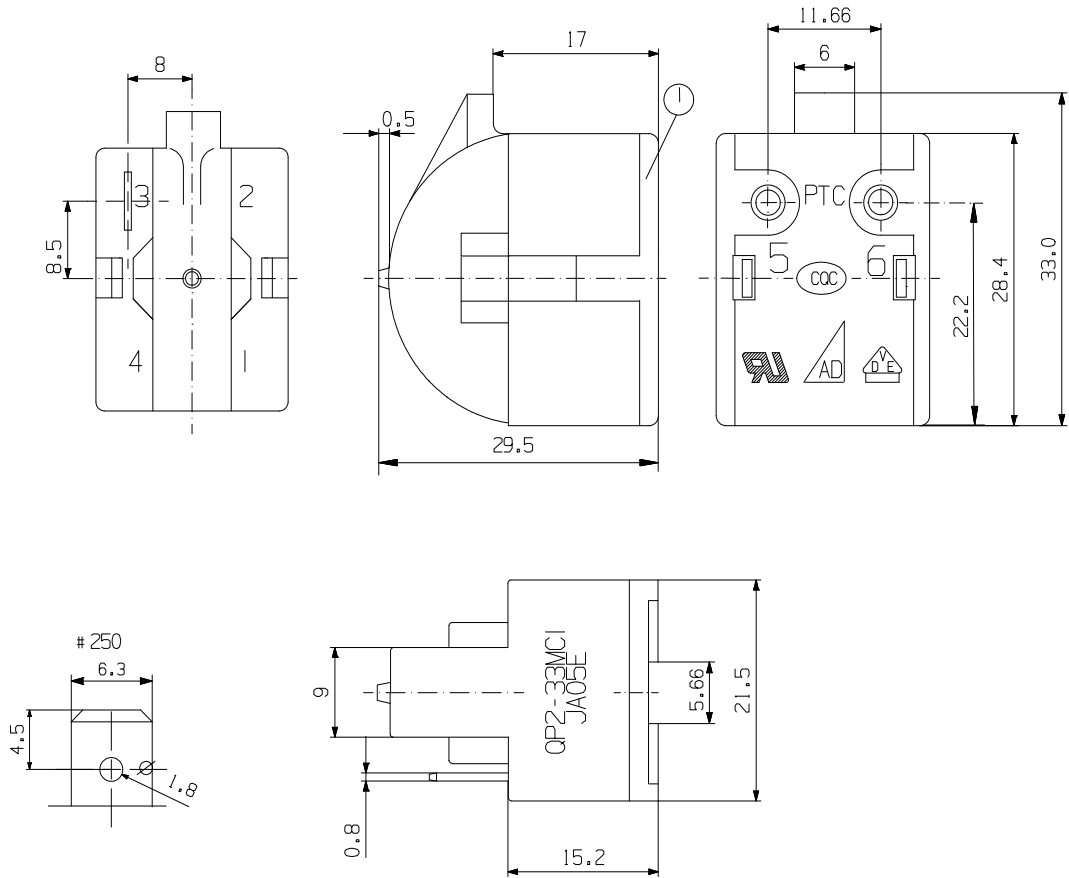

10-1. Overload Protector

Specification	4TM213SFBY
MAKER	Sensata Technologies

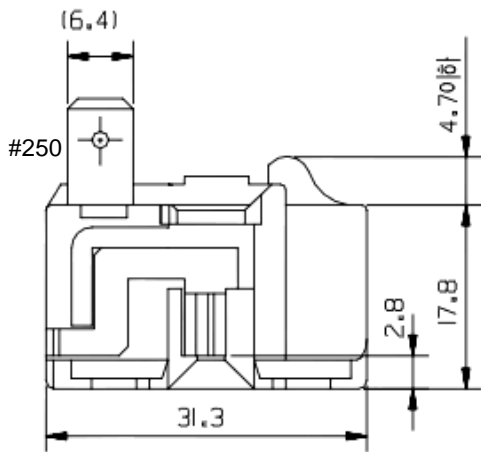
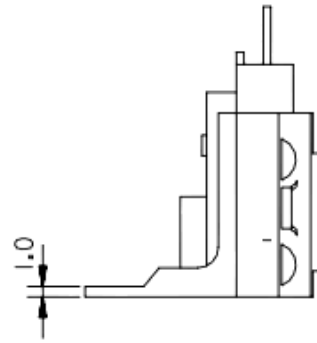
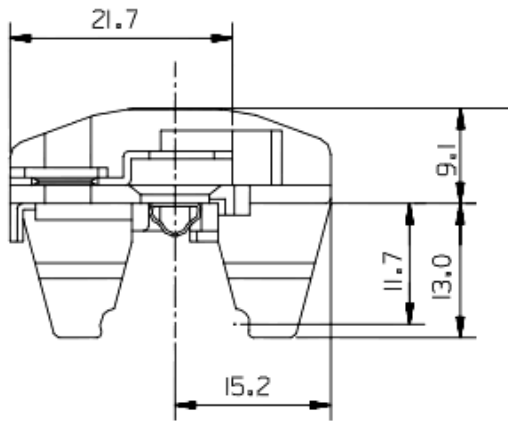

250TAB-T0.8

11. Mounting Accessory

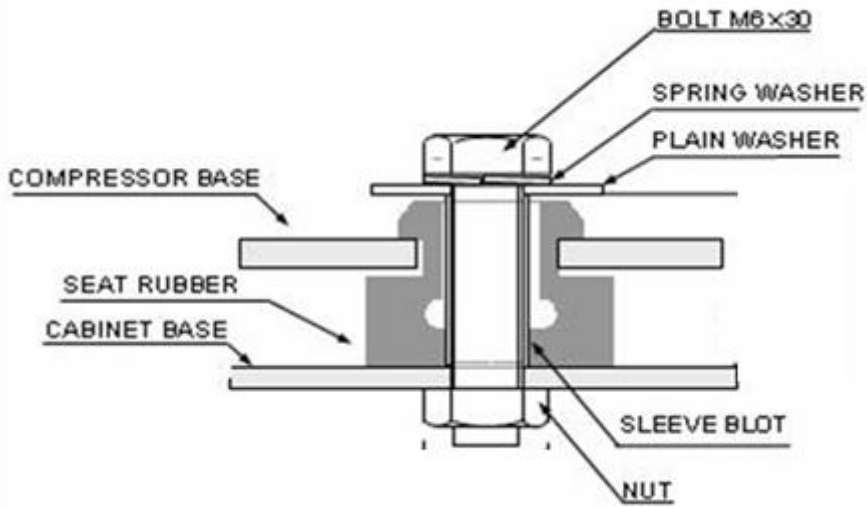

Grommet

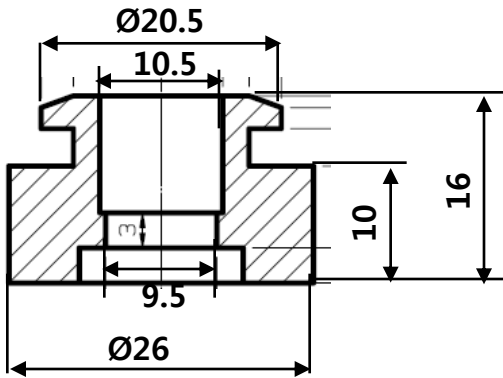

Sleeve, Bolt

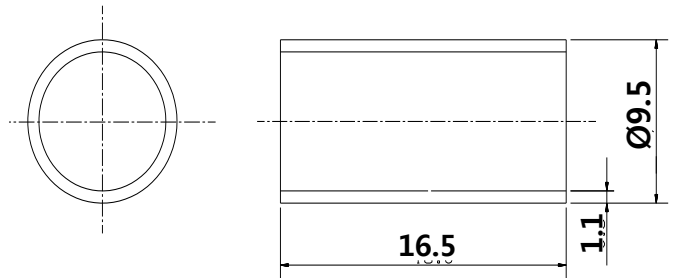

Bolt Assembly

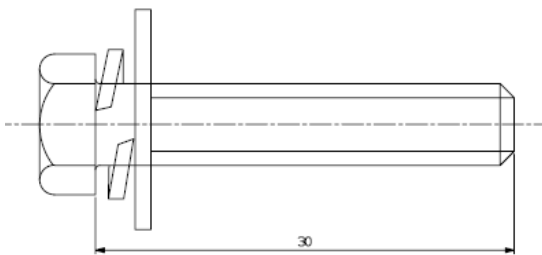



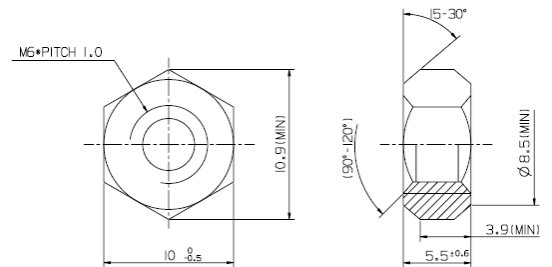





Nut Common



13. Transportation

Shipment positions of refrigeration appliances

<p>Gravity Direction</p> 	<p>Normal</p>	<p>Bracket Mount UP</p>
		
<p>Gravity Direction</p> 	<p>Pipe Down</p>	<p>Pipe up</p>
		
<p>Gravity Direction</p> 	<p>Electrical lead-in up</p>	<p>Electrical lead-in Down</p>
		

13. Compressor Packing

Specifications

	Direction	CMA
Dimension mm(inch)	W	1,100(43.3)
	D	830(32.7)
	H	1100(43.3)
Q'ty(EA)		90 (3*6*5 Load)

*** Stacking : 2pallets max. compressor**

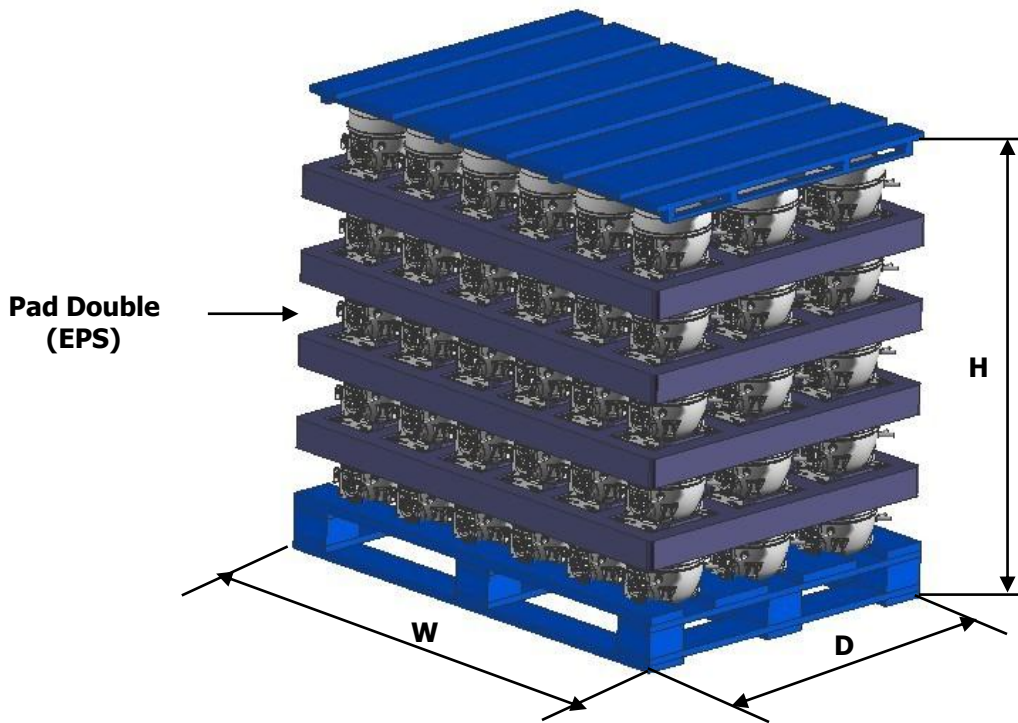

<CMA Packing Cover View>

14. Compressor Label

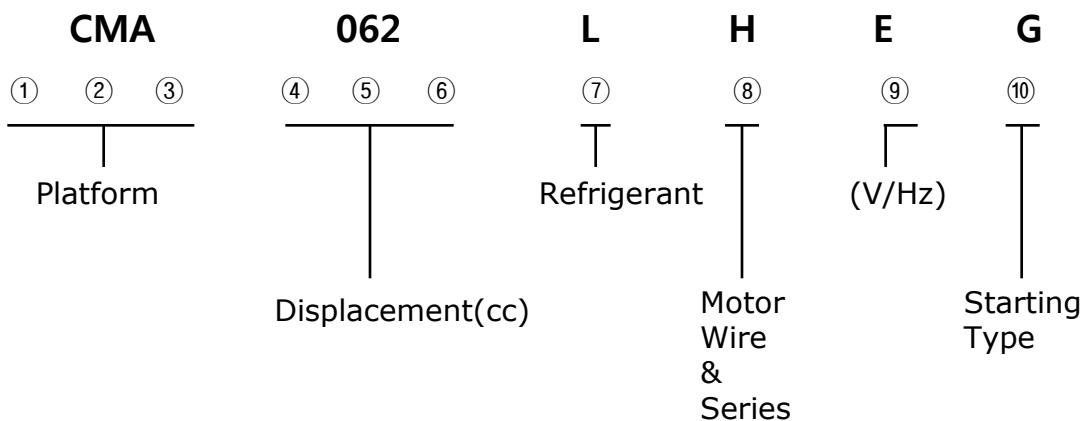

1 2 3 : CMA

4 5 6 : 062

7 : L - R134a, N - R600a H - R134a(H.B.P)

8 : Cu motor: A, B, C... // Al Motor H, J, K...

9 : A - 100/50,60 D - 220/60, C - 115/60, E - 220~240/50, J - 220/50, M - 220~240/50,60

10 : G - RSIR, M - RSCR, H - CSR, F - CSIR

