

50Hz AC Fan Coil Unit 2-Pipe Wall-mounted Series Technical Service Manual

Content

| | |
|------------------------------------|-----------|
| 1.INTRODUCTION | 2 |
| 2.NOMENCLATURE..... | 2 |
| 3.PRODUCT SCHEDULE | 2 |
| 4.EXTERNAL APPEARANCE | 3 |
| 5.FEATURE | 3 |
| 6.SPECIFICATIONS | 5 |
| 7.DIMENSIONS | 9 |
| 8.SERVICE SPACES..... | 10 |
| 9.WIRING DIAGRAMS..... | 11 |
| 10.CAPACITY TABLES..... | 12 |
| 11.SOUND LEVELS | 26 |
| 12.EXPLODED VIEW | 27 |
| 13.INSTALLATION | 29 |
| 14.CONTROLLER | 40 |

1. Introduction

MKG fan coil is a kind of newly designed fan coil units, which is mounted on the wall. It has two kinds of body, both have 3-way valve inside the body. In additional, it has panels of different color can be optional.

MKG series fan coil is designed and manufactured on the base of fully adoption advanced technology. The acute and thin body makes it save a lot of space and easy for installation. Quality materials and state-of-the-art technology ensure optimal performance with virtually imperceptible noise levels and keep running smoothly.

Tadiran MKG series fan coil unit has been tested by national AC quality supervise testing center, as low noise level, high efficiency, stable operation and low power consumption make it as the advanced production in the world,. Due to their reduced dimensions and pleasing design, these units are ideally suited for Commercial and Residential environments.

2. Nomenclature

T K G – 250 - B

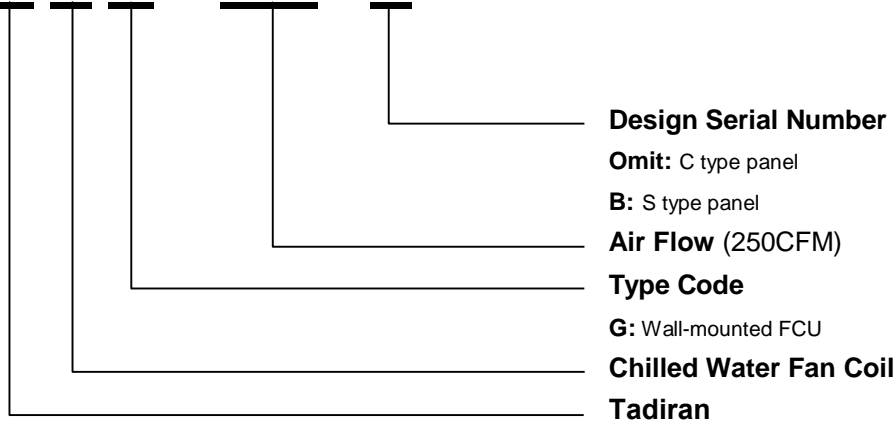

3. Product Schedule

| Series | Model | Air volume (CFM) | Power supply |
|--------------|-----------|------------------|-------------------|
| C type panel | TKG-250 | 250 | 220~240V-1Ph-50Hz |
| | TKG-300 | 300 | |
| | TKG-400 | 400 | |
| | TKG-500 | 500 | |
| | TKG-600 | 600 | |
| S type panel | TKG-250-B | 250 | 220~240V-1Ph-50Hz |
| | TKG-300-B | 300 | |
| | TKG-400-B | 400 | |
| | TKG-500-B | 500 | |
| | TKG-600-B | 600 | |

4. External Appearance



C panel



S panel

5. Feature

- ◆ Multi-connection outlet pipe method: left/right/rear, more flexible for installation.

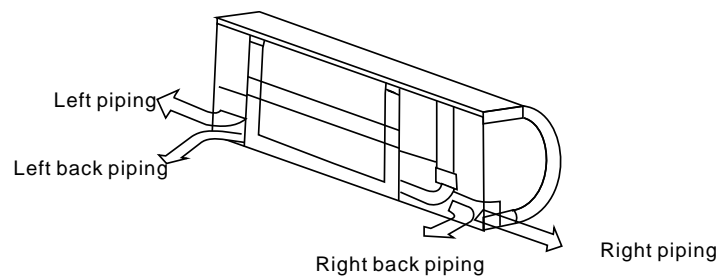

- ◆ Wind direction adjustment can be in horizontal and vertical way for auto swing louver

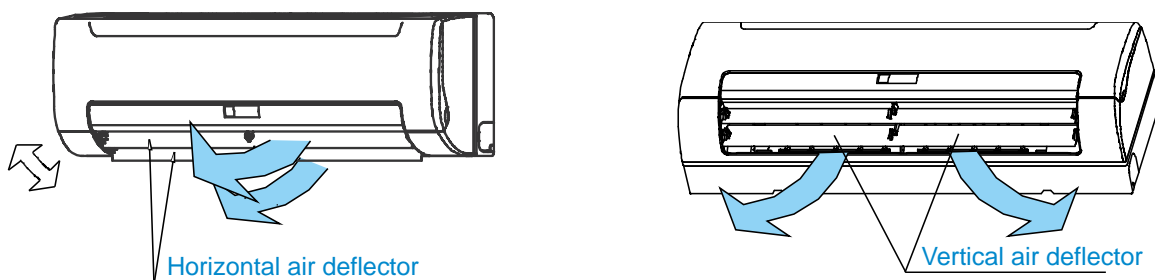

- ◆ Built-in 3-way electromagnetic valve.
- ◆ Cross flow fan creates quiet and comfortable environment.
- ◆ Easy maintenance has been realized as the front panel can be removed for easy access.

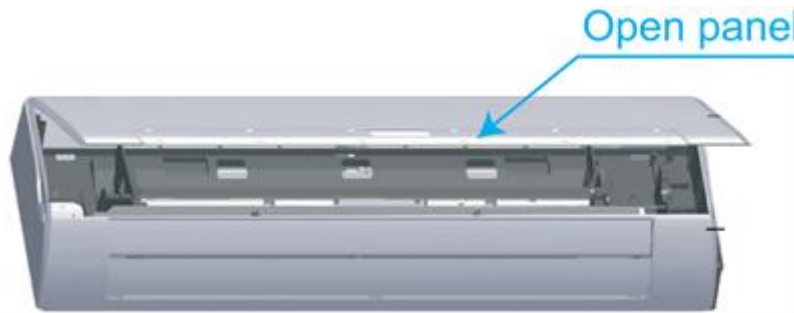

- ◆ Remote controller with LCD display is standard, wired controller and central controller are optional.
- ◆ Four-speed motor with super high speed reserved for more choice.
- ◆ Eurovent certified performance.

You can get the eurovent information of our products from: <http://www.eurovent-certification.com>



6. Specifications

| Model TKG- | | | | 250 | 300 | 400 |
|----------------------|-------------------------|-------|-------------------|-----------------------------|----------------|----------------|
| Air flow | | H/M/L | m ³ /h | 425/360/320 | 510/430/380 | 680/580/510 |
| | | H/M/L | CFM | 250/210/190 | 300/250/220 | 400/340/300 |
| Cooling | Capacity | H/M/L | kW | 2.2/1.84/1.65 | 2.64/2.24/2.05 | 3.08/2.62/2.27 |
| | Water flow rate | H | L/h | 378 | 454 | 530 |
| | Water pressure drop | H | kPa | 12 | 18 | 22 |
| Heating | Capacity | H/M/L | kW | 3.02/2.6/2.23 | 3.69/3.25/2.77 | 4.34/3.86/3.25 |
| | Water pressure drop | H | kPa | 10 | 16.4 | 20.8 |
| Power supply | | | V/Ph/Hz | 220-240/1/50 | | |
| Power input | | H | W | 28 | 40 | 44 |
| Current input | | H | A | 0.1 | 0.16 | 0.18 |
| Sound pressure level | | H/M/L | dB(A) | 30/24/20 | 35/29/24 | 37/31/26 |
| Fan motor | Type | | | Low noise 4-speed fan motor | | |
| | Quantity | | | 1 | | |
| Fan | Type | | | Cross-flow fan | | |
| | Quantity | | | 1 | | |
| Coil | Row | | | 2 | | |
| | Max. Working pressure | | MPa | 1.6 | | |
| | Diameter | | mm | Φ7 | | |
| Body | Dimensions | W×H×D | mm | 915×210×290 | | |
| | Net weight | | | kg | 12 | |
| | Packing | W×H×D | mm | 1020×300×385 | | |
| | Gross weight | | | kg | 16 | |
| Pipe connection | Water inlet/outlet pipe | | inch | G3/4" | | |
| | Drain pipe | | mm | ODΦ20 | | |
| Controller | | | | R51/E (standard) | | |

Notes:

1. H: high fan speed; M: medium fan speed; L: low fan speed
2. Cooling Conditions: Entering Water 7°C, Temperature Rise 5°C, Entering Air Temperature 27°C DB, 19°C WB.
Heating Conditions: Entering Water 50°C, Enter air temperature 20°C, and water flow is same to the cooling conditions.
3. Noise is tested in semi-anechoic test room.

Specifications

| Model TKG- | | | | 500 | 600 |
|----------------------|-------------------------|-------|-------------------|-----------------------------|----------------|
| Air flow | | H/M/L | m ³ /h | 850/720/640 | 1020/870/770 |
| | | H/M/L | CFM | 500/420/380 | 600/510/450 |
| Cooling | Capacity | H/M/L | kW | 4.07/3.73/3.24 | 4.45/4.18/3.74 |
| | Water flow rate | H | L/h | 700 | 765 |
| | Water pressure drop | H | kPa | 26 | 29 |
| Heating | Capacity | H/M/L | kW | 5.69/5.12/4.32 | 6.3/5.67/4.73 |
| | Water pressure drop | H | kPa | 25.1 | 27.9 |
| Power supply | | | V/Ph/Hz | 220-240/1/50 | |
| Power input | | H | W | 50 | 60 |
| Current input | | H | A | 0.22 | 0.30 |
| Sound pressure level | | H/M/L | dB(A) | 39/33/28 | 40/34/29 |
| Fan motor | Type | | | Low noise 4-speed fan motor | |
| | Quantity | | | 1 | |
| Fan | Type | | | Cross-flow fan | |
| | Quantity | | | 1 | |
| Coil | Row | | | 2 | |
| | Max. Working pressure | | MPa | 1.6 | |
| | Diameter | | mm | Φ7 | |
| Body | Dimensions | W×H×D | mm | 1070×210×316 | |
| | Net weight | | | kg | |
| | Packing | W×H×D | mm | 1180×300×410 | |
| | Gross weight | | | kg | |
| Pipe connection | Water inlet/outlet pipe | | inch | G3/4" | |
| | Drain pipe | | mm | ODΦ20 | |
| Controller | | | | R51/E (standard) | |

Notes:

1. H: high fan speed; M: medium fan speed; L: low fan speed
2. Cooling Conditions: Entering Water 7°C, Temperature Rise 5°C, Entering Air Temperature 27°C DB, 19°C WB.
Heating Conditions: Entering Water 50°C, Enter air temperature 20°C, and water flow is same to the cooling conditions.
3. Noise is tested in semi-anechoic test room.

Specifications

| Model | | | TKG-250-B | TKG-300-B | TKG-400-B |
|-----------------------|------------------------------|-------------------|-----------------------------|----------------|----------------|
| Power supply | | V/Ph/Hz | 220-240/1/50 | | |
| Air flow (H/M/L) | | m ³ /h | 425/390/350 | 510/470/390 | 680/550/460 |
| | | CFM | 250/230/205 | 300/275/230 | 400/325/270 |
| Cooling | Capacity (H/M/L) | kW | 2.63/2.41/2.16 | 2.97/2.47/2.12 | 3.28/2.83/2.41 |
| | Water flow rate | L/h | 452 | 511 | 564 |
| | Water pressure drop | kPa | 29.4 | 35.6 | 43.5 |
| Heating | Capacity (H/M/L) | kW | 3.36/3.1/2.79 | 3.91/3.26/2.77 | 4.37/3.73/3.17 |
| | Water pressure drop | kPa | 27.3 | 32.9 | 40.8 |
| Power input | | W | 24 | 37 | 40 |
| Current input | | H | A | 0.12 | 0.18 |
| Sound pressure level | | dB(A) | 30/24/20 | 35/29/24 | 37/31/26 |
| Fan motor | Type | | Low noise 4-speed fan motor | | |
| | Quantity | | 1 | | |
| Fan | Type | | Tangential fan | | |
| | Quantity | | 1 | | |
| Coil | Row | | 2 | | |
| | Diameter | mm | Φ7 | | |
| | Tube pitch(a) × row pitch(b) | mm | 21×13.37 | | |
| | Dimension (W×H×D) | mm | 635×315×26.74 | | |
| | Fin spacing | mm | 1.5 | | |
| | Fin type | | Hydrophilic aluminum | | |
| | Circuit | | 5 | | |
| Max. working pressure | | MPa | 1.6 | | |
| Body | Net dimensions (W×H×D) | | 915×290×230 | | |
| | Packing size (W×H×D) | | 1020×390×315 | | |
| | Net weight | kg | 13 | 13 | 13.3 |
| | Gross weight | kg | 16.3 | 16.3 | 16.7 |
| Pipe connections | Water inlet/outlet pipe | | G3/4 | | |
| | Drain pipe | | ODΦ20 | | |

Notes:

1. H: high fan speed; M: medium fan speed; L: low fan speed
2. Cooling Conditions: Entering Water 7°C, Temperature Rise 5°C, Entering Air Temperature 27°C DB, 19°C WB.
Heating Conditions: Entering Water 50°C, Enter air temperature 20°C, and water flow is same to the cooling conditions.
3. Noise is tested in semi-anechoic test room.

Specifications

| Model | | | TKG-500-B | TKG-600-B |
|-----------------------|------------------------------|-------------------|-----------------------------|------------------|
| Power supply | | V/Ph/Hz | 220-240/1/50 | |
| Air flow (H/M/L) | | m ³ /h | 850/745/620 | 1020/915/780 |
| | | CFM | 500/440/365 | 600/540/460 |
| Cooling | Capacity (H/M/L) | kW | 4.25/3.85/3.32 | 5/4.47/3.97 |
| | Water flow rate | L/h | 731 | 860 |
| | Water pressure drop | kPa | 31.8 | 42.5 |
| Heating | Capacity (H/M/L) | kW | 5.81/5.17/4.43 | 6.7/6/5.28 |
| | Water pressure drop | kPa | 30.2 | 39.7 |
| Power input | | W | 50 | 66 |
| Current input | | A | 0.22 | 0.27 |
| Sound pressure level | | dB(A) | 39/33/28 | 40/34/29 |
| Fan motor | Type | | Low noise 4-speed fan motor | |
| | Quantity | | 1 | |
| Fan | Type | | Tangential fan | |
| | Quantity | | 1 | |
| Coil | Row | | 2 | |
| | Diameter | mm | Φ7 | |
| | Tube pitch(a) × row pitch(b) | mm | 21×13.37 | |
| | Dimension (W×H×D) | mm | 785×315×26.74 | |
| | Fin spacing | mm | 1.5 | |
| | Fin type | | Hydrophilic aluminum | |
| | Circuit | | 5 | |
| Max. working pressure | | MPa | 1.6 | |
| Body | Net dimensions (W×H×D) | mm | 1072×315×230 | |
| | Packing size (W×H×D) | mm | 1180×415×315 | |
| | Net weight | kg | 15.8 | 15.8 |
| | Gross weight | kg | 19.4 | 19.4 |
| Pipe connections | Water inlet/outlet pipe | inch | G3/4 | |
| | Drain pipe | mm | ODΦ20 | |

Notes:

1. H: high fan speed; M: medium fan speed; L: low fan speed
2. Cooling Conditions: Entering Water 7°C, Temperature Rise 5°C, Entering Air Temperature 27°C DB, 19°C WB.
Heating Conditions: Entering Water 50°C, Enter air temperature 20°C, and water flow is same to the cooling conditions.
3. Noise is tested in semi-anechoic test room.

7. Dimensions

C-panel

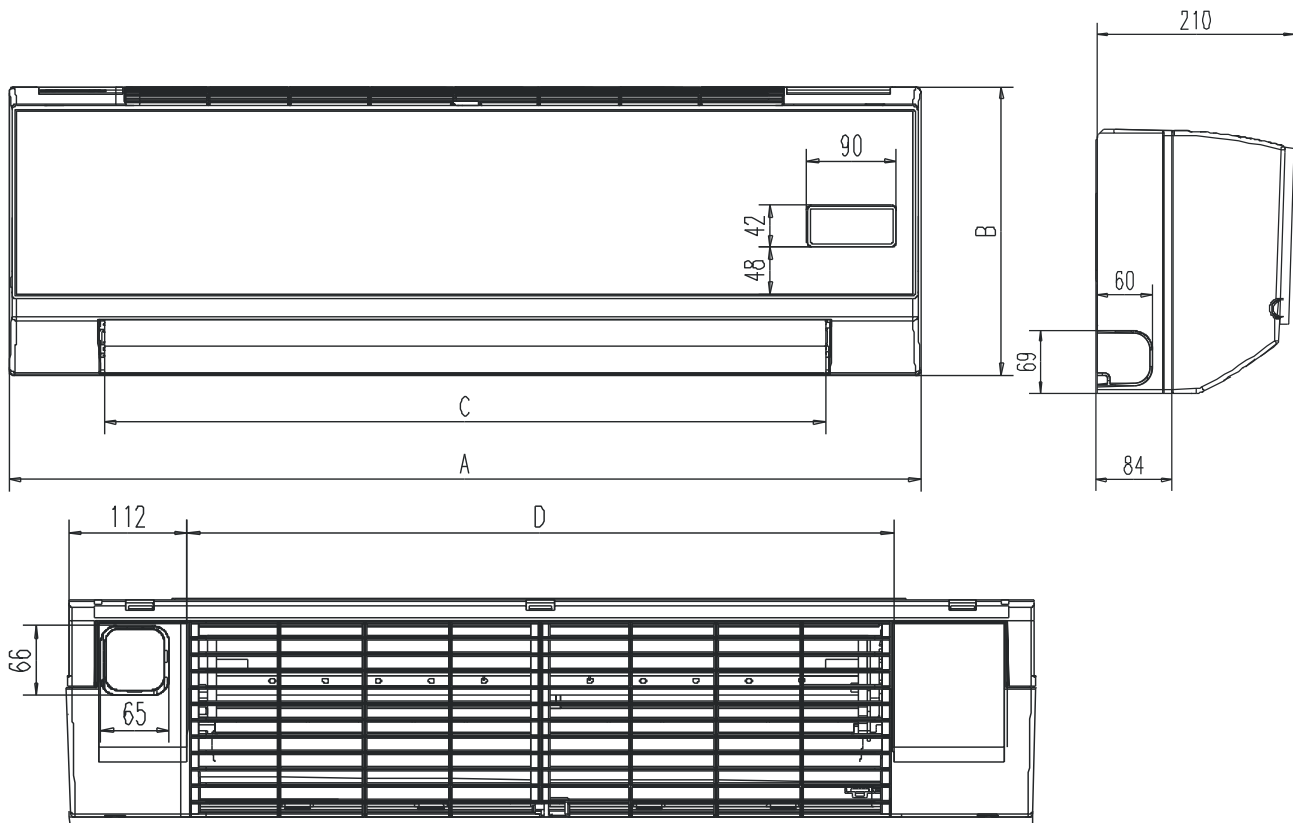

| Model | TKG-250 | TKG-300 | TKG-400 | TKG-500 | TKG-600 |
|-------|---------|---------|---------|---------|---------|
| A | 915 | 915 | 915 | 1070 | 1070 |
| B | 290 | 290 | 290 | 315 | 315 |
| C | 725 | 725 | 725 | 885 | 885 |
| D | 670 | 670 | 670 | 815 | 815 |

S-panel

TKG-250-B, TKG-300-G, TKG-400-B

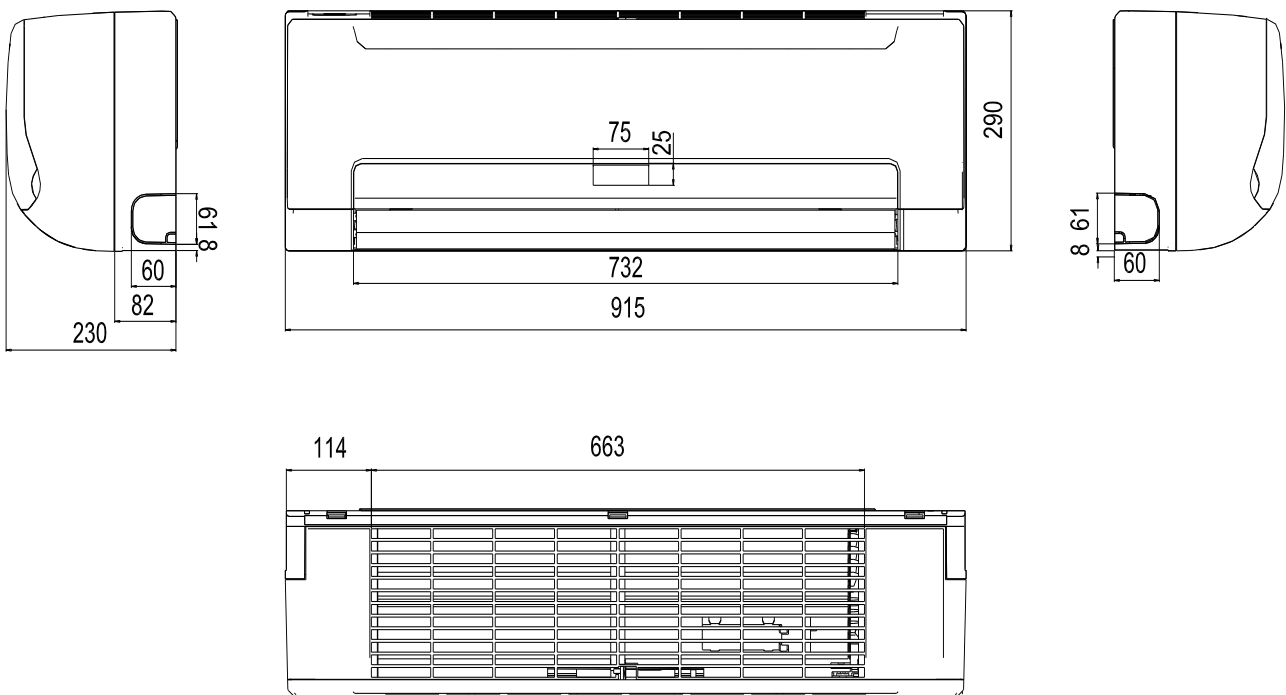

TKG-500-B, TKG-600-B

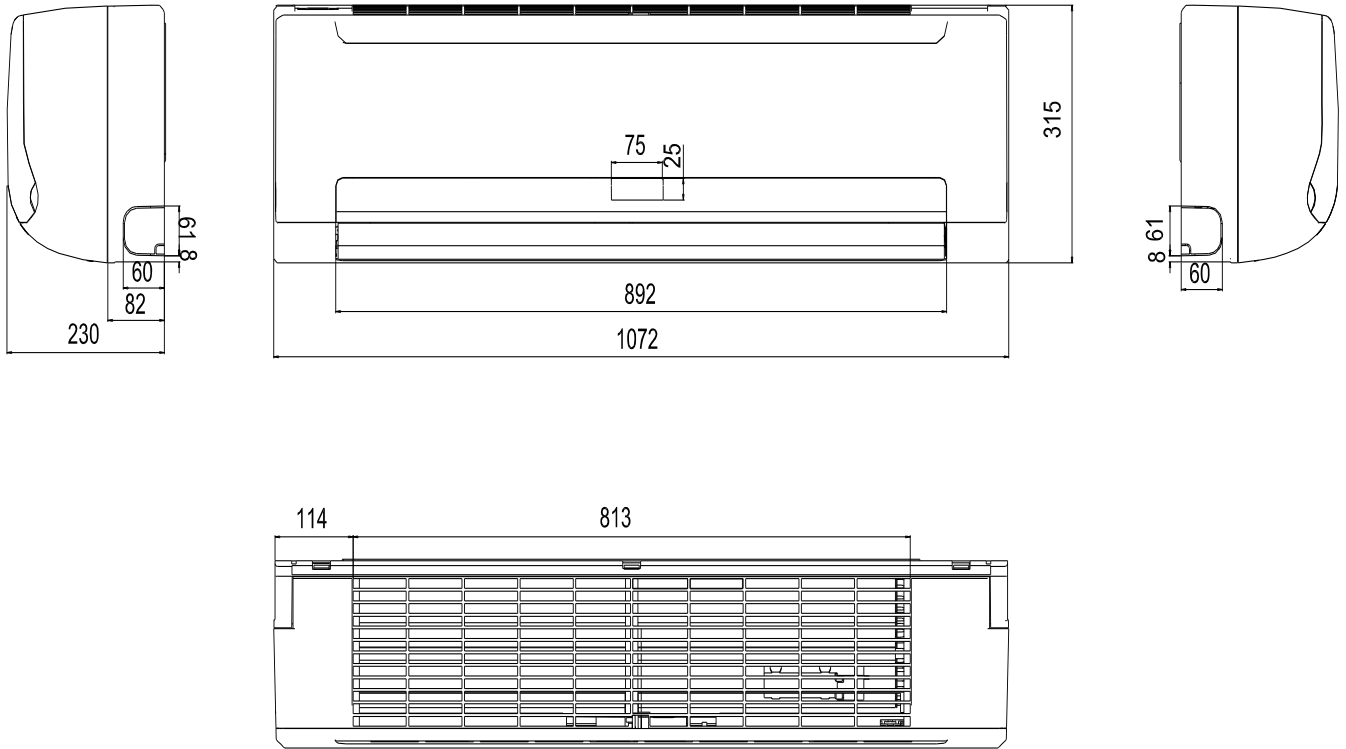

8. Service Spaces

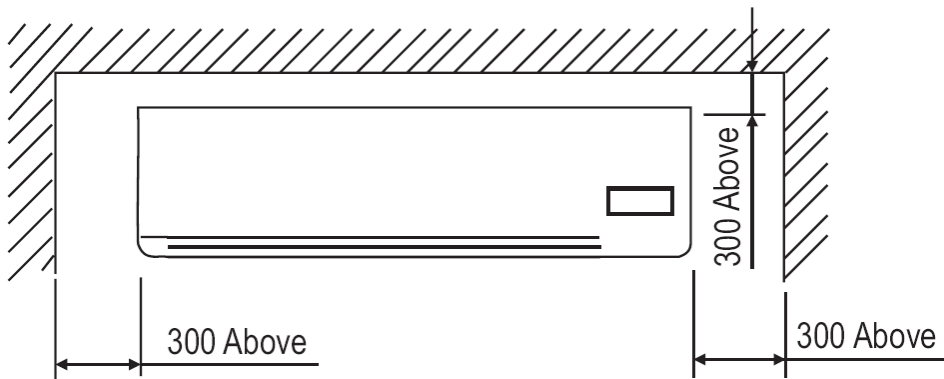

9. Wiring Diagrams

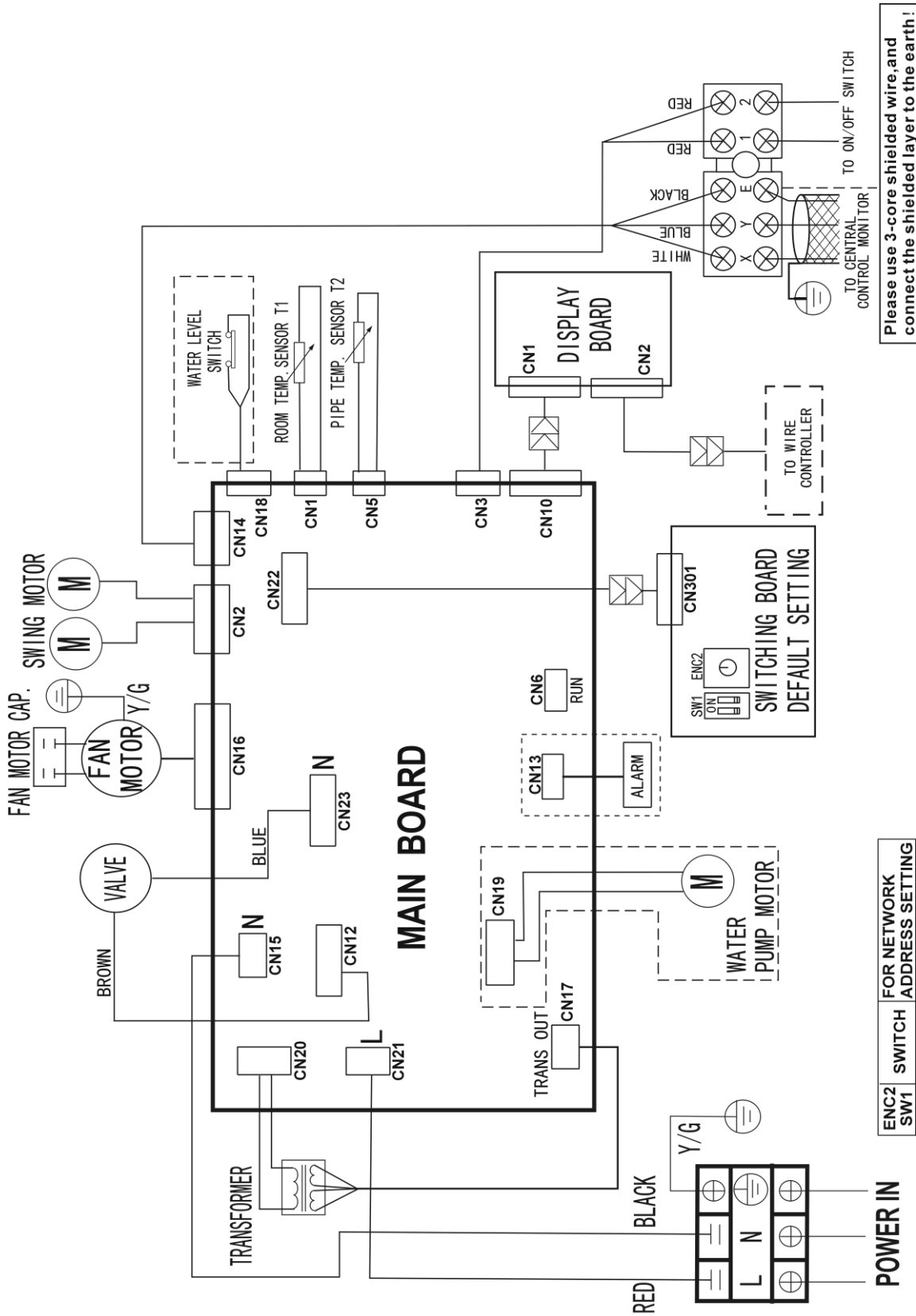

Note:
The function in the dashed rectangle are available for particular air-conditioner.

10. Capacity Tables

C panel Cooling capacity

EWT: Enter Water Temp. (°C) **Δt:** Temperature Difference (°C) **DB:** Dry Bulb Temp. (°C) **WB:** Wet Bulb Temp. (°C)

TC: Total Cooling Capacity (kW) **SC:** Sensible Cooling Capacity (kW) **WF:** Water Flow (m³/h) **WPD:** Water Pressure Drop (kPa)

| TKG-250 | | | | | | | | | | | | | | | | | | | | | |
|---------|----|---------------------|------|------|------|-------------|------|------|------|-------------|------|------|------|-------------|------|------|------|-------------|------|------|------|
| EWT | Δt | Air inlet condition | | | | | | | | | | | | | | | | | | | |
| | | DB:26.7 WB:19.4 | | | | DB:27 WB:18 | | | | DB:27 WB:19 | | | | DB:27 WB:20 | | | | DB:29 WB:21 | | | |
| | | TC | SC | WF | WPD | TC | SC | WF | WPD | TC | SC | WF | WPD | TC | SC | WF | WPD | TC | SC | WF | WPD |
| 5 | 3 | 2.8 | 1.69 | 0.8 | 54.1 | 2.57 | 1.86 | 0.74 | 45.5 | 2.75 | 1.76 | 0.79 | 51.9 | 2.9 | 1.69 | 0.83 | 58.1 | 3.07 | 1.61 | 0.88 | 64.8 |
| | 4 | 2.7 | 1.64 | 0.58 | 28.1 | 2.48 | 1.8 | 0.53 | 23.8 | 2.65 | 1.71 | 0.57 | 27.2 | 2.81 | 1.64 | 0.6 | 30.5 | 2.95 | 1.56 | 0.63 | 33.6 |
| | 5 | 2.58 | 1.58 | 0.44 | 16.5 | 2.36 | 1.76 | 0.41 | 13.8 | 2.53 | 1.66 | 0.43 | 15.8 | 2.7 | 1.58 | 0.46 | 18.0 | 2.83 | 2.45 | 0.49 | 19.9 |
| | 6 | 2.46 | 1.54 | 0.35 | 10.5 | 2.24 | 1.7 | 0.32 | 8.7 | 2.42 | 1.6 | 0.35 | 10.1 | 2.58 | 1.52 | 0.37 | 11.5 | 2.71 | 1.44 | 0.39 | 12.6 |
| | 7 | 2.34 | 1.46 | 0.29 | 6.9 | 2.12 | 1.66 | 0.26 | 5.7 | 2.29 | 1.55 | 0.28 | 6.6 | 2.46 | 1.46 | 0.3 | 7.6 | 2.59 | 1.38 | 0.32 | 8.5 |
| 6 | 3 | 2.64 | 1.62 | 0.76 | 48.2 | 2.41 | 1.79 | 0.69 | 40.0 | 2.58 | 1.69 | 0.74 | 46.0 | 2.75 | 1.61 | 0.79 | 52.2 | 2.91 | 1.54 | 0.83 | 58.4 |
| | 4 | 2.54 | 1.57 | 0.55 | 25.0 | 2.3 | 1.73 | 0.49 | 20.5 | 2.48 | 1.63 | 0.53 | 23.8 | 2.64 | 1.56 | 0.57 | 27.1 | 2.79 | 1.49 | 0.6 | 30.2 |
| | 5 | 2.42 | 1.51 | 0.42 | 14.5 | 2.2 | 1.68 | 0.38 | 12.0 | 2.37 | 1.59 | 0.41 | 13.9 | 2.52 | 1.5 | 0.43 | 15.8 | 2.68 | 1.43 | 0.46 | 17.8 |
| | 6 | 2.3 | 1.46 | 0.33 | 9.1 | 2.08 | 1.63 | 0.3 | 7.5 | 2.25 | 1.53 | 0.32 | 8.7 | 2.42 | 1.44 | 0.35 | 10.1 | 2.55 | 1.37 | 0.37 | 11.2 |
| | 7 | 2.18 | 1.4 | 0.27 | 6.0 | 1.95 | 1.58 | 0.24 | 4.8 | 2.13 | 1.49 | 0.26 | 5.7 | 2.28 | 1.39 | 0.28 | 6.6 | 2.43 | 1.31 | 0.3 | 7.5 |
| 7 | 3 | 2.47 | 1.54 | 0.71 | 42.0 | 2.24 | 1.72 | 0.64 | 34.6 | 2.42 | 1.62 | 0.69 | 40.2 | 2.59 | 1.54 | 0.74 | 46.3 | 2.74 | 1.46 | 0.79 | 51.7 |
| | 4 | 2.37 | 1.49 | 0.51 | 21.7 | 2.12 | 1.68 | 0.46 | 17.5 | 2.3 | 1.57 | 0.5 | 20.6 | 2.48 | 1.49 | 0.53 | 23.8 | 2.63 | 1.41 | 0.57 | 26.8 |
| | 5 | 2.25 | 1.43 | 0.39 | 12.5 | 2.02 | 1.63 | 0.35 | 10.1 | 2.2 | 1.51 | 0.38 | 12.0 | 2.36 | 1.42 | 0.41 | 13.8 | 2.5 | 1.36 | 0.43 | 15.6 |
| | 6 | 2.13 | 1.39 | 0.31 | 7.8 | 1.9 | 1.57 | 0.27 | 6.2 | 2.09 | 1.46 | 0.3 | 7.5 | 2.25 | 1.37 | 0.32 | 8.7 | 2.39 | 1.3 | 0.34 | 9.8 |
| | 7 | 2.02 | 1.33 | 0.25 | 5.1 | 1.77 | 1.52 | 0.22 | 4.0 | 1.95 | 1.42 | 0.24 | 4.8 | 2.12 | 1.32 | 0.26 | 5.7 | 2.26 | 1.24 | 0.28 | 6.5 |
| 8 | 3 | 2.3 | 1.48 | 0.66 | 36.5 | 2.05 | 1.66 | 0.59 | 29.1 | 2.25 | 1.55 | 0.64 | 34.8 | 2.42 | 1.46 | 0.69 | 40.3 | 2.57 | 1.38 | 0.74 | 45.7 |
| | 4 | 2.2 | 1.43 | 0.47 | 18.8 | 1.95 | 1.6 | 0.42 | 14.8 | 2.13 | 1.51 | 0.46 | 17.6 | 2.3 | 1.41 | 0.49 | 20.5 | 2.45 | 1.34 | 0.53 | 23.3 |
| | 5 | 2.09 | 1.37 | 0.36 | 10.8 | 1.83 | 1.56 | 0.32 | 8.3 | 2.03 | 1.45 | 0.35 | 10.2 | 2.2 | 1.36 | 0.38 | 12.0 | 2.35 | 1.29 | 0.4 | 13.7 |
| | 6 | 1.95 | 1.32 | 0.28 | 6.6 | 1.71 | 1.51 | 0.25 | 5.1 | 1.91 | 1.4 | 0.27 | 6.3 | 2.08 | 1.3 | 0.3 | 7.5 | 2.23 | 1.23 | 0.32 | 8.6 |
| | 7 | 1.84 | 1.26 | 0.23 | 4.3 | 1.59 | 1.45 | 0.2 | 3.2 | 1.78 | 1.35 | 0.22 | 4.0 | 1.95 | 1.25 | 0.24 | 4.8 | 2.09 | 1.17 | 0.26 | 5.5 |
| 9 | 3 | 2.14 | 1.41 | 0.61 | 31.5 | 1.88 | 1.59 | 0.54 | 24.4 | 2.08 | 1.48 | 0.6 | 29.8 | 2.26 | 1.39 | 0.65 | 35.1 | 2.4 | 1.31 | 0.69 | 39.8 |
| | 4 | 2.02 | 1.36 | 0.43 | 15.8 | 1.77 | 1.55 | 0.38 | 12.2 | 1.96 | 1.43 | 0.42 | 14.9 | 2.13 | 1.35 | 0.46 | 17.5 | 2.28 | 1.27 | 0.49 | 20.1 |
| | 5 | 1.91 | 1.3 | 0.33 | 9.1 | 1.64 | 1.51 | 0.28 | 6.7 | 1.85 | 1.39 | 0.32 | 8.5 | 2.02 | 1.29 | 0.35 | 10.1 | 2.17 | 1.21 | 0.37 | 11.7 |
| | 6 | 1.78 | 1.25 | 0.26 | 5.5 | 1.51 | 1.46 | 0.22 | 4.0 | 1.72 | 1.34 | 0.25 | 5.1 | 1.9 | 1.23 | 0.27 | 6.3 | 2.05 | 1.15 | 0.29 | 7.3 |
| | 7 | 1.65 | 1.19 | 0.2 | 3.5 | 1.41 | / | 0.17 | 2.5 | 1.59 | 1.28 | 0.2 | 3.2 | 1.77 | 1.19 | 0.22 | 3.9 | 1.91 | 1.1 | 0.23 | 4.6 |
| 10 | 3 | 1.96 | 1.34 | 0.56 | 26.5 | 1.69 | 1.53 | 0.48 | 19.6 | 1.88 | 1.43 | 0.54 | 24.4 | 2.07 | 1.33 | 0.59 | 29.6 | 2.23 | 1.24 | 0.64 | 34.4 |
| | 4 | 1.84 | 1.29 | 0.4 | 13.1 | 1.56 | 1.5 | 0.34 | 9.5 | 1.78 | 1.38 | 0.38 | 12.2 | 1.96 | 1.28 | 0.42 | 14.9 | 2.1 | 1.2 | 0.45 | 17.2 |
| | 5 | 1.72 | 1.24 | 0.3 | 7.3 | 1.46 | / | 0.25 | 5.3 | 1.65 | 1.33 | 0.28 | 6.7 | 1.83 | 1.23 | 0.32 | 8.4 | 1.99 | 1.14 | 0.34 | 9.9 |
| | 6 | 1.6 | 1.19 | 0.23 | 4.4 | 1.39 | / | 0.2 | 3.3 | 1.53 | 1.28 | 0.22 | 4.0 | 1.71 | 1.16 | 0.25 | 5.1 | 1.86 | 1.09 | 0.27 | 6.0 |
| | 7 | 1.46 | 1.14 | 0.18 | 2.7 | 1.3 | / | 0.16 | 2.2 | 1.39 | 1.23 | 0.17 | 2.5 | 1.57 | 1.13 | 0.19 | 3.1 | 1.74 | 1.03 | 0.21 | 3.8 |
| 11 | 3 | 1.77 | 1.28 | 0.51 | 21.6 | 1.5 | / | 0.43 | 15.5 | 1.71 | 1.36 | 0.49 | 20.1 | 1.89 | 1.27 | 0.54 | 24.5 | 2.05 | 1.18 | 0.59 | 29.1 |
| | 4 | 1.66 | 1.23 | 0.36 | 10.7 | 1.43 | / | 0.31 | 7.9 | 1.59 | 1.31 | 0.34 | 9.8 | 1.77 | 1.21 | 0.38 | 12.2 | 1.94 | 1.13 | 0.42 | 14.6 |
| | 5 | 1.53 | 1.18 | 0.26 | 5.8 | 1.36 | / | 0.23 | 4.6 | 1.46 | 1.28 | 0.25 | 5.3 | 1.65 | 1.16 | 0.28 | 6.8 | 1.81 | 1.08 | 0.31 | 8.2 |
| | 6 | 1.4 | 1.14 | 0.2 | 3.4 | 1.27 | / | 0.18 | 2.8 | 1.34 | 1.22 | 0.19 | 3.1 | 1.52 | 1.12 | 0.22 | 4.0 | 1.68 | 1.02 | 0.24 | 4.9 |
| | 7 | 1.24 | 1.1 | 0.15 | 2.0 | 1.2 | / | 0.15 | 1.8 | 1.2 | / | 0.15 | 1.8 | 1.38 | 1.06 | 0.17 | 2.4 | 1.55 | 0.96 | 0.19 | 3.0 |
| 12 | 3 | 1.58 | 1.22 | 0.45 | 17.3 | 1.39 | / | 0.4 | 13.3 | 1.51 | 1.31 | 0.43 | 15.7 | 1.71 | 1.2 | 0.49 | 20.1 | 1.87 | 1.11 | 0.54 | 24.0 |
| | 4 | 1.47 | 1.17 | 0.32 | 8.3 | 1.32 | / | 0.28 | 6.8 | 1.39 | 1.27 | 0.3 | 7.5 | 1.59 | 1.15 | 0.34 | 9.8 | 1.76 | 1.06 | 0.38 | 11.9 |
| | 5 | 1.34 | 1.13 | 0.23 | 4.5 | 1.27 | / | 0.22 | 4.0 | 1.27 | 1.23 | 0.22 | 4.0 | 1.46 | 1.11 | 0.25 | 5.3 | 1.63 | 1.02 | 0.28 | 6.6 |
| | 6 | 1.19 | 1.1 | 0.17 | 2.4 | 1.18 | / | 0.17 | 2.4 | 1.18 | 1.16 | 0.17 | 2.4 | 1.33 | 1.06 | 0.19 | 3.0 | 1.49 | 0.96 | 0.21 | 3.8 |
| | 7 | 1.05 | / | 0.13 | 1.4 | 1.1 | / | 0.13 | 1.5 | 1.09 | / | 0.13 | 1.5 | 1.16 | 1.01 | 0.14 | 1.7 | 1.36 | 0.9 | 0.17 | 2.3 |
| 13 | 3 | 1.38 | 1.16 | 0.4 | 13.2 | 1.28 | / | 0.37 | 11.3 | 1.3 | 1.26 | 0.37 | 11.7 | 1.5 | 1.14 | 0.43 | 15.6 | 1.68 | 1.05 | 0.48 | 19.5 |
| | 4 | 1.27 | 1.12 | 0.27 | 6.2 | 1.22 | / | 0.26 | 5.8 | 1.22 | 1.2 | 0.26 | 5.8 | 1.38 | 1.11 | 0.3 | 7.4 | 1.56 | 1 | 0.34 | 9.5 |
| | 5 | 1.13 | 1.1 | 0.19 | 3.2 | 1.14 | / | 0.2 | 3.2 | 1.14 | / | 0.2 | 3.2 | 1.26 | 1.06 | 0.22 | 4.0 | 1.44 | 0.95 | 0.25 | 5.1 |
| | 6 | 1.03 | / | 0.15 | 1.8 | 1.06 | / | 0.15 | 2.0 | 1.06 | / | 0.15 | 2.0 | 1.11 | 1.02 | 0.16 | 2.1 | 1.3 | 0.9 | 0.19 | 2.9 |
| | 7 | 0.94 | / | 0.12 | 1.1 | 0.97 | / | 0.12 | 1.2 | 0.98 | / | 0.12 | 1.2 | 0.98 | 0.96 | 0.12 | 1.2 | 1.14 | 0.85 | 0.14 | 1.6 |

Cooling Capacity

| TKG-300 | | | | | | | | | | | | | | | | | | | | | | |
|---------|----|---------------------|------|------|------|-------------|------|------|------|-------------|------|------|------|-------------|------|------|------|-------------|------|------|------|--|
| EWT | Δt | Air inlet condition | | | | | | | | | | | | | | | | | | | | |
| | | DB:26.7 WB:19.4 | | | | DB:27 WB:18 | | | | DB:27 WB:19 | | | | DB:27 WB:20 | | | | DB:29 WB:21 | | | | |
| | | TC | SC | WF | WPD | TC | SC | WF | WPD | TC | SC | WF | WPD | TC | SC | WF | WPD | TC | SC | WF | WPD | |
| 5 | 3 | 3.36 | 2.03 | 0.96 | 81.2 | 3.09 | 2.23 | 0.88 | 68.3 | 3.3 | 2.11 | 0.94 | 77.9 | 3.49 | 2.02 | 1 | 87.2 | 3.68 | 1.93 | 1.05 | 97.2 | |
| | 4 | 3.23 | 1.97 | 0.7 | 42.2 | 2.97 | 2.16 | 0.64 | 35.6 | 3.18 | 2.05 | 0.68 | 40.8 | 3.37 | 1.97 | 0.72 | 45.8 | 3.54 | 1.87 | 0.76 | 50.4 | |
| | 5 | 3.09 | 1.9 | 0.53 | 24.7 | 2.83 | 2.11 | 0.49 | 20.7 | 3.03 | 1.99 | 0.52 | 23.8 | 3.23 | 1.89 | 0.56 | 27.0 | 3.4 | 2.94 | 0.58 | 29.8 | |
| | 6 | 2.96 | 1.84 | 0.42 | 15.7 | 2.69 | 2.04 | 0.39 | 13.0 | 2.9 | 1.92 | 0.42 | 15.1 | 3.1 | 1.82 | 0.44 | 17.3 | 3.25 | 1.73 | 0.47 | 18.9 | |
| | 7 | 2.81 | 1.76 | 0.35 | 10.4 | 2.54 | 1.99 | 0.31 | 8.5 | 2.75 | 1.86 | 0.34 | 9.9 | 2.95 | 1.76 | 0.36 | 11.5 | 3.11 | 1.66 | 0.38 | 12.8 | |
| 6 | 3 | 3.17 | 1.95 | 0.91 | 72.2 | 2.89 | 2.14 | 0.83 | 60.0 | 3.1 | 2.03 | 0.89 | 69.0 | 3.3 | 1.94 | 0.95 | 78.3 | 3.49 | 1.84 | 1 | 87.6 | |
| | 4 | 3.05 | 1.88 | 0.66 | 37.5 | 2.76 | 2.08 | 0.59 | 30.8 | 2.98 | 1.96 | 0.64 | 35.7 | 3.17 | 1.87 | 0.68 | 40.6 | 3.35 | 1.78 | 0.72 | 45.4 | |
| | 5 | 2.9 | 1.81 | 0.5 | 21.7 | 2.64 | 2.02 | 0.45 | 18.0 | 2.84 | 1.9 | 0.49 | 20.9 | 3.03 | 1.79 | 0.52 | 23.7 | 3.22 | 1.71 | 0.55 | 26.8 | |
| | 6 | 2.76 | 1.76 | 0.4 | 13.7 | 2.5 | 1.95 | 0.36 | 11.2 | 2.7 | 1.83 | 0.39 | 13.1 | 2.9 | 1.73 | 0.42 | 15.1 | 3.06 | 1.64 | 0.44 | 16.8 | |
| | 7 | 2.62 | 1.68 | 0.32 | 9.0 | 2.34 | 1.9 | 0.29 | 7.2 | 2.55 | 1.78 | 0.31 | 8.6 | 2.74 | 1.67 | 0.34 | 9.9 | 2.92 | 1.57 | 0.36 | 11.3 | |
| 7 | 3 | 2.96 | 1.85 | 0.85 | 63.0 | 2.69 | 2.06 | 0.77 | 51.9 | 2.9 | 1.95 | 0.83 | 60.3 | 3.11 | 1.85 | 0.89 | 69.5 | 3.29 | 1.75 | 0.94 | 77.5 | |
| | 4 | 2.84 | 1.79 | 0.61 | 32.6 | 2.55 | 2.02 | 0.55 | 26.2 | 2.77 | 1.88 | 0.59 | 30.9 | 2.97 | 1.79 | 0.64 | 35.6 | 3.16 | 1.7 | 0.68 | 40.3 | |
| | 5 | 2.7 | 1.72 | 0.46 | 18.8 | 2.42 | 1.95 | 0.42 | 15.1 | 2.64 | 1.82 | 0.45 | 18.0 | 2.83 | 1.71 | 0.49 | 20.7 | 3.01 | 1.63 | 0.52 | 23.3 | |
| | 6 | 2.56 | 1.67 | 0.37 | 11.7 | 2.28 | 1.89 | 0.33 | 9.3 | 2.51 | 1.75 | 0.36 | 11.3 | 2.7 | 1.64 | 0.39 | 13.1 | 2.87 | 1.55 | 0.41 | 14.8 | |
| | 7 | 2.42 | 1.6 | 0.3 | 7.7 | 2.13 | 1.82 | 0.26 | 6.0 | 2.34 | 1.7 | 0.29 | 7.2 | 2.54 | 1.59 | 0.31 | 8.5 | 2.72 | 1.49 | 0.33 | 9.7 | |
| 8 | 3 | 2.76 | 1.77 | 0.79 | 54.7 | 2.46 | 1.99 | 0.71 | 43.6 | 2.7 | 1.86 | 0.77 | 52.2 | 2.9 | 1.75 | 0.83 | 60.5 | 3.09 | 1.66 | 0.89 | 68.5 | |
| | 4 | 2.64 | 1.71 | 0.57 | 28.1 | 2.34 | 1.92 | 0.5 | 22.2 | 2.56 | 1.81 | 0.55 | 26.5 | 2.76 | 1.7 | 0.59 | 30.8 | 2.94 | 1.61 | 0.63 | 34.9 | |
| | 5 | 2.51 | 1.64 | 0.43 | 16.2 | 2.2 | 1.87 | 0.38 | 12.5 | 2.43 | 1.74 | 0.42 | 15.3 | 2.64 | 1.63 | 0.45 | 18.0 | 2.82 | 1.54 | 0.48 | 20.5 | |
| | 6 | 2.34 | 1.59 | 0.34 | 9.8 | 2.06 | 1.82 | 0.29 | 7.6 | 2.3 | 1.68 | 0.33 | 9.5 | 2.5 | 1.56 | 0.36 | 11.2 | 2.67 | 1.47 | 0.38 | 12.8 | |
| | 7 | 2.21 | 1.52 | 0.27 | 6.4 | 1.91 | 1.74 | 0.23 | 4.8 | 2.14 | 1.62 | 0.26 | 6.0 | 2.34 | 1.5 | 0.29 | 7.2 | 2.5 | 1.41 | 0.31 | 8.3 | |
| 9 | 3 | 2.57 | 1.69 | 0.74 | 47.3 | 2.26 | 1.91 | 0.65 | 36.6 | 2.5 | 1.78 | 0.72 | 44.7 | 2.71 | 1.66 | 0.78 | 52.6 | 2.88 | 1.58 | 0.83 | 59.7 | |
| | 4 | 2.42 | 1.63 | 0.52 | 23.7 | 2.13 | 1.86 | 0.46 | 18.2 | 2.35 | 1.72 | 0.51 | 22.3 | 2.55 | 1.62 | 0.55 | 26.3 | 2.74 | 1.52 | 0.59 | 30.2 | |
| | 5 | 2.29 | 1.56 | 0.39 | 13.6 | 1.97 | 1.81 | 0.34 | 10.0 | 2.22 | 1.66 | 0.38 | 12.7 | 2.42 | 1.55 | 0.42 | 15.1 | 2.6 | 1.45 | 0.45 | 17.5 | |
| | 6 | 2.14 | 1.5 | 0.31 | 8.2 | 1.82 | 1.76 | 0.26 | 5.9 | 2.06 | 1.61 | 0.3 | 7.7 | 2.29 | 1.48 | 0.33 | 9.4 | 2.46 | 1.38 | 0.35 | 10.9 | |
| | 7 | 1.98 | 1.43 | 0.24 | 5.2 | 1.7 | / | 0.21 | 3.8 | 1.91 | 1.54 | 0.23 | 4.8 | 2.12 | 1.43 | 0.26 | 5.9 | 2.29 | 1.32 | 0.28 | 6.9 | |
| 10 | 3 | 2.35 | 1.6 | 0.67 | 39.8 | 2.03 | 1.84 | 0.58 | 29.5 | 2.26 | 1.71 | 0.65 | 36.6 | 2.49 | 1.6 | 0.71 | 44.4 | 2.68 | 1.49 | 0.77 | 51.6 | |
| | 4 | 2.21 | 1.54 | 0.48 | 19.7 | 1.87 | 1.8 | 0.4 | 14.2 | 2.13 | 1.65 | 0.46 | 18.4 | 2.35 | 1.54 | 0.51 | 22.3 | 2.53 | 1.44 | 0.54 | 25.7 | |
| | 5 | 2.06 | 1.49 | 0.36 | 11.0 | 1.76 | / | 0.3 | 8.0 | 1.98 | 1.6 | 0.34 | 10.1 | 2.2 | 1.47 | 0.38 | 12.5 | 2.39 | 1.37 | 0.41 | 14.8 | |
| | 6 | 1.92 | 1.43 | 0.28 | 6.6 | 1.66 | / | 0.24 | 5.0 | 1.84 | 1.54 | 0.26 | 6.1 | 2.06 | 1.39 | 0.29 | 7.6 | 2.24 | 1.3 | 0.32 | 9.0 | |
| | 7 | 1.76 | 1.37 | 0.22 | 4.1 | 1.57 | / | 0.19 | 3.2 | 1.67 | 1.48 | 0.21 | 3.7 | 1.89 | 1.35 | 0.23 | 4.7 | 2.09 | 1.24 | 0.26 | 5.8 | |
| 11 | 3 | 2.13 | 1.53 | 0.61 | 32.4 | 1.8 | / | 0.52 | 23.3 | 2.05 | 1.63 | 0.59 | 30.1 | 2.26 | 1.52 | 0.65 | 36.7 | 2.46 | 1.41 | 0.71 | 43.6 | |
| | 4 | 1.99 | 1.48 | 0.43 | 16.0 | 1.71 | / | 0.37 | 11.9 | 1.91 | 1.57 | 0.41 | 14.8 | 2.13 | 1.45 | 0.46 | 18.3 | 2.33 | 1.36 | 0.5 | 21.9 | |
| | 5 | 1.84 | 1.42 | 0.32 | 8.7 | 1.63 | / | 0.28 | 6.9 | 1.76 | 1.53 | 0.3 | 8.0 | 1.98 | 1.39 | 0.34 | 10.1 | 2.18 | 1.29 | 0.37 | 12.2 | |
| | 6 | 1.68 | 1.36 | 0.24 | 5.0 | 1.53 | / | 0.22 | 4.2 | 1.61 | 1.46 | 0.23 | 4.7 | 1.83 | 1.34 | 0.26 | 6.0 | 2.02 | 1.23 | 0.29 | 7.3 | |
| | 7 | 1.49 | 1.31 | 0.18 | 2.9 | 1.44 | / | 0.18 | 2.7 | 1.44 | / | 0.18 | 2.7 | 1.66 | 1.28 | 0.2 | 3.6 | 1.86 | 1.15 | 0.23 | 4.6 | |
| 12 | 3 | 1.9 | 1.46 | 0.54 | 25.9 | 1.67 | / | 0.48 | 20.0 | 1.81 | 1.57 | 0.52 | 23.5 | 2.05 | 1.44 | 0.59 | 30.1 | 2.24 | 1.34 | 0.64 | 36.0 | |
| | 4 | 1.76 | 1.41 | 0.38 | 12.5 | 1.59 | / | 0.34 | 10.2 | 1.67 | 1.52 | 0.36 | 11.3 | 1.9 | 1.38 | 0.41 | 14.6 | 2.11 | 1.28 | 0.45 | 17.9 | |
| | 5 | 1.61 | 1.36 | 0.28 | 6.7 | 1.52 | / | 0.26 | 6.0 | 1.52 | 1.47 | 0.26 | 6.0 | 1.76 | 1.33 | 0.3 | 8.0 | 1.95 | 1.22 | 0.34 | 9.9 | |
| | 6 | 1.43 | 1.31 | 0.2 | 3.7 | 1.41 | / | 0.2 | 3.6 | 1.41 | 1.39 | 0.2 | 3.6 | 1.59 | 1.28 | 0.23 | 4.6 | 1.79 | 1.15 | 0.26 | 5.8 | |
| | 7 | 1.26 | / | 0.16 | 2.1 | 1.31 | / | 0.16 | 2.3 | 1.3 | / | 0.16 | 2.2 | 1.39 | 1.21 | 0.17 | 2.6 | 1.63 | 1.08 | 0.2 | 3.5 | |
| 13 | 3 | 1.66 | 1.39 | 0.48 | 19.8 | 1.54 | / | 0.44 | 17.0 | 1.57 | 1.51 | 0.45 | 17.6 | 1.81 | 1.37 | 0.52 | 23.4 | 2.02 | 1.26 | 0.58 | 29.3 | |
| | 4 | 1.52 | 1.34 | 0.33 | 9.3 | 1.47 | / | 0.32 | 8.7 | 1.47 | 1.44 | 0.32 | 8.7 | 1.66 | 1.33 | 0.36 | 11.1 | 1.87 | 1.2 | 0.4 | 14.2 | |
| | 5 | 1.36 | 1.33 | 0.23 | 4.8 | 1.37 | / | 0.24 | 4.8 | 1.37 | / | 0.24 | 4.9 | 1.52 | 1.27 | 0.26 | 5.9 | 1.73 | 1.14 | 0.3 | 7.7 | |
| | 6 | 1.23 | / | 0.18 | 2.7 | 1.28 | / | 0.18 | 2.9 | 1.28 | / | 0.18 | 2.9 | 1.34 | 1.22 | 0.19 | 3.2 | 1.56 | 1.08 | 0.22 | 4.4 | |
| | 7 | 1.13 | / | 0.14 | 1.7 | 1.17 | / | 0.14 | 1.8 | 1.17 | / | 0.14 | 1.8 | 1.17 | 1.15 | 0.14 | 1.8 | 1.36 | 1.02 | 0.17 | 2.5 | |

Cooling Capacity

| TKG-400 | | | | | | | | | | | | | | | | | | | | | | |
|---------|----|---------------------|------|------|------|-------------|------|------|------|-------------|------|------|------|-------------|------|------|-------|-------------|------|------|-------|--|
| EWT | Δt | Air inlet condition | | | | | | | | | | | | | | | | | | | | |
| | | DB:26.7 WB:19.4 | | | | DB:27 WB:18 | | | | DB:27 WB:19 | | | | DB:27 WB:20 | | | | DB:29 WB:21 | | | | |
| | | TC | SC | WF | WPD | TC | SC | WF | WPD | TC | SC | WF | WPD | TC | SC | WF | WPD | TC | SC | WF | WPD | |
| 5 | 3 | 3.92 | 2.36 | 1.13 | 99.2 | 3.6 | 2.6 | 1.03 | 83.5 | 3.84 | 2.47 | 1.1 | 95.2 | 4.07 | 2.36 | 1.17 | 106.5 | 4.29 | 2.25 | 1.23 | 118.7 | |
| | 4 | 3.77 | 2.29 | 0.81 | 51.6 | 3.47 | 2.52 | 0.75 | 43.6 | 3.71 | 2.4 | 0.8 | 49.9 | 3.93 | 2.29 | 0.84 | 55.9 | 4.12 | 2.18 | 0.89 | 61.6 | |
| | 5 | 3.61 | 2.21 | 0.62 | 30.2 | 3.3 | 2.46 | 0.57 | 25.3 | 3.54 | 2.32 | 0.61 | 29.0 | 3.77 | 2.21 | 0.65 | 33.0 | 3.96 | 3.43 | 0.68 | 36.5 | |
| | 6 | 3.45 | 2.15 | 0.49 | 19.2 | 3.14 | 2.38 | 0.45 | 15.9 | 3.38 | 2.24 | 0.48 | 18.4 | 3.62 | 2.12 | 0.52 | 21.1 | 3.79 | 2.02 | 0.54 | 23.2 | |
| | 7 | 3.28 | 2.05 | 0.4 | 12.7 | 2.97 | 2.32 | 0.36 | 10.4 | 3.2 | 2.16 | 0.39 | 12.2 | 3.44 | 2.05 | 0.42 | 14.0 | 3.63 | 1.94 | 0.45 | 15.6 | |
| 6 | 3 | 3.7 | 2.27 | 1.06 | 88.3 | 3.37 | 2.5 | 0.97 | 73.3 | 3.62 | 2.37 | 1.04 | 84.3 | 3.85 | 2.26 | 1.1 | 95.7 | 4.08 | 2.15 | 1.17 | 107.0 | |
| | 4 | 3.56 | 2.19 | 0.76 | 45.8 | 3.22 | 2.42 | 0.69 | 37.6 | 3.47 | 2.29 | 0.75 | 43.7 | 3.7 | 2.19 | 0.8 | 49.7 | 3.91 | 2.08 | 0.84 | 55.4 | |
| | 5 | 3.38 | 2.11 | 0.58 | 26.5 | 3.08 | 2.36 | 0.53 | 21.9 | 3.32 | 2.22 | 0.57 | 25.5 | 3.53 | 2.09 | 0.61 | 29.0 | 3.76 | 2 | 0.65 | 32.7 | |
| | 6 | 3.22 | 2.05 | 0.46 | 16.7 | 2.92 | 2.28 | 0.42 | 13.7 | 3.15 | 2.14 | 0.45 | 16.0 | 3.38 | 2.01 | 0.48 | 18.4 | 3.57 | 1.91 | 0.51 | 20.5 | |
| | 7 | 3.05 | 1.96 | 0.38 | 11.0 | 2.73 | 2.22 | 0.34 | 8.8 | 2.98 | 2.08 | 0.37 | 10.5 | 3.19 | 1.95 | 0.39 | 12.1 | 3.41 | 1.83 | 0.42 | 13.8 | |
| 7 | 3 | 3.46 | 2.16 | 0.99 | 77.0 | 3.14 | 2.4 | 0.9 | 63.4 | 3.38 | 2.27 | 0.97 | 73.7 | 3.63 | 2.16 | 1.04 | 84.9 | 3.84 | 2.04 | 1.1 | 94.8 | |
| | 4 | 3.32 | 2.08 | 0.71 | 39.8 | 2.97 | 2.35 | 0.64 | 32.0 | 3.23 | 2.2 | 0.69 | 37.7 | 3.47 | 2.08 | 0.75 | 43.6 | 3.68 | 1.98 | 0.79 | 49.2 | |
| | 5 | 3.15 | 2.01 | 0.54 | 23.0 | 2.82 | 2.28 | 0.49 | 18.5 | 3.08 | 2.12 | 0.53 | 22.0 | 3.3 | 1.99 | 0.57 | 25.3 | 3.51 | 1.9 | 0.6 | 28.5 | |
| | 6 | 2.98 | 1.95 | 0.43 | 14.3 | 2.66 | 2.2 | 0.38 | 11.4 | 2.93 | 2.04 | 0.42 | 13.8 | 3.15 | 1.92 | 0.45 | 16.0 | 3.35 | 1.81 | 0.48 | 18.0 | |
| | 7 | 2.82 | 1.86 | 0.35 | 9.4 | 2.48 | 2.12 | 0.3 | 7.3 | 2.73 | 1.98 | 0.34 | 8.8 | 2.96 | 1.85 | 0.36 | 10.4 | 3.17 | 1.74 | 0.39 | 11.9 | |
| 8 | 3 | 3.22 | 2.07 | 0.92 | 66.9 | 2.88 | 2.32 | 0.82 | 53.3 | 3.15 | 2.16 | 0.9 | 63.8 | 3.39 | 2.04 | 0.97 | 73.9 | 3.6 | 1.93 | 1.03 | 83.7 | |
| | 4 | 3.08 | 2 | 0.66 | 34.4 | 2.73 | 2.24 | 0.59 | 27.1 | 2.99 | 2.12 | 0.64 | 32.3 | 3.22 | 1.98 | 0.69 | 37.6 | 3.43 | 1.88 | 0.74 | 42.7 | |
| | 5 | 2.92 | 1.91 | 0.5 | 19.8 | 2.56 | 2.18 | 0.44 | 15.3 | 2.84 | 2.03 | 0.49 | 18.7 | 3.08 | 1.91 | 0.53 | 21.9 | 3.28 | 1.8 | 0.56 | 25.0 | |
| | 6 | 2.73 | 1.85 | 0.39 | 12.0 | 2.4 | 2.12 | 0.34 | 9.3 | 2.68 | 1.96 | 0.38 | 11.6 | 2.92 | 1.82 | 0.42 | 13.7 | 3.12 | 1.72 | 0.45 | 15.7 | |
| | 7 | 2.57 | 1.77 | 0.32 | 7.8 | 2.23 | 2.03 | 0.27 | 5.9 | 2.49 | 1.89 | 0.31 | 7.4 | 2.73 | 1.75 | 0.34 | 8.8 | 2.92 | 1.64 | 0.36 | 10.1 | |
| 9 | 3 | 3 | 1.97 | 0.86 | 57.8 | 2.64 | 2.23 | 0.76 | 44.8 | 2.91 | 2.07 | 0.83 | 54.6 | 3.16 | 1.94 | 0.91 | 64.3 | 3.36 | 1.84 | 0.96 | 72.9 | |
| | 4 | 2.83 | 1.9 | 0.61 | 29.0 | 2.48 | 2.16 | 0.53 | 22.3 | 2.74 | 2.01 | 0.59 | 27.3 | 2.98 | 1.89 | 0.64 | 32.1 | 3.19 | 1.77 | 0.69 | 36.9 | |
| | 5 | 2.68 | 1.82 | 0.46 | 16.6 | 2.29 | 2.12 | 0.39 | 12.2 | 2.59 | 1.94 | 0.45 | 15.6 | 2.82 | 1.81 | 0.49 | 18.5 | 3.04 | 1.69 | 0.52 | 21.4 | |
| | 6 | 2.5 | 1.76 | 0.36 | 10.1 | 2.12 | 2.05 | 0.3 | 7.2 | 2.41 | 1.88 | 0.35 | 9.4 | 2.67 | 1.72 | 0.38 | 11.5 | 2.88 | 1.61 | 0.41 | 13.3 | |
| | 7 | 2.31 | 1.67 | 0.28 | 6.3 | 1.98 | / | 0.24 | 4.6 | 2.23 | 1.8 | 0.27 | 5.9 | 2.47 | 1.67 | 0.3 | 7.2 | 2.68 | 1.54 | 0.33 | 8.5 | |
| 10 | 3 | 2.75 | 1.87 | 0.79 | 48.6 | 2.36 | 2.15 | 0.68 | 36.0 | 2.64 | 2 | 0.76 | 44.8 | 2.9 | 1.86 | 0.83 | 54.3 | 3.13 | 1.74 | 0.9 | 63.1 | |
| | 4 | 2.58 | 1.8 | 0.55 | 24.1 | 2.19 | 2.1 | 0.47 | 17.3 | 2.49 | 1.93 | 0.54 | 22.5 | 2.74 | 1.79 | 0.59 | 27.3 | 2.95 | 1.68 | 0.63 | 31.5 | |
| | 5 | 2.41 | 1.74 | 0.41 | 13.5 | 2.05 | / | 0.35 | 9.7 | 2.31 | 1.87 | 0.4 | 12.3 | 2.57 | 1.72 | 0.44 | 15.3 | 2.79 | 1.6 | 0.48 | 18.1 | |
| | 6 | 2.24 | 1.67 | 0.32 | 8.1 | 1.94 | / | 0.28 | 6.1 | 2.14 | 1.8 | 0.31 | 7.4 | 2.4 | 1.63 | 0.34 | 9.3 | 2.61 | 1.52 | 0.37 | 11.0 | |
| | 7 | 2.05 | 1.6 | 0.25 | 5.0 | 1.83 | / | 0.22 | 4.0 | 1.95 | 1.73 | 0.24 | 4.5 | 2.2 | 1.58 | 0.27 | 5.7 | 2.44 | 1.44 | 0.3 | 7.0 | |
| 11 | 3 | 2.48 | 1.79 | 0.71 | 39.6 | 2.1 | / | 0.6 | 28.5 | 2.39 | 1.9 | 0.69 | 36.8 | 2.64 | 1.78 | 0.76 | 44.9 | 2.88 | 1.65 | 0.82 | 53.3 | |
| | 4 | 2.32 | 1.72 | 0.5 | 19.6 | 2 | / | 0.43 | 14.5 | 2.23 | 1.83 | 0.48 | 18.0 | 2.48 | 1.69 | 0.53 | 22.4 | 2.72 | 1.58 | 0.58 | 26.7 | |
| | 5 | 2.15 | 1.66 | 0.37 | 10.7 | 1.9 | / | 0.33 | 8.4 | 2.05 | 1.79 | 0.35 | 9.7 | 2.31 | 1.62 | 0.4 | 12.4 | 2.54 | 1.51 | 0.44 | 14.9 | |
| | 6 | 1.96 | 1.59 | 0.28 | 6.2 | 1.78 | / | 0.26 | 5.1 | 1.88 | 1.71 | 0.27 | 5.7 | 2.13 | 1.57 | 0.31 | 7.3 | 2.36 | 1.43 | 0.34 | 8.9 | |
| | 7 | 1.74 | 1.53 | 0.21 | 3.6 | 1.68 | / | 0.21 | 3.3 | 1.68 | / | 0.21 | 3.3 | 1.93 | 1.49 | 0.24 | 4.4 | 2.17 | 1.35 | 0.27 | 5.6 | |
| 12 | 3 | 2.22 | 1.7 | 0.64 | 31.7 | 1.95 | / | 0.56 | 24.4 | 2.11 | 1.84 | 0.61 | 28.7 | 2.39 | 1.68 | 0.69 | 36.8 | 2.61 | 1.56 | 0.75 | 44.0 | |
| | 4 | 2.05 | 1.64 | 0.44 | 15.3 | 1.85 | / | 0.4 | 12.5 | 1.95 | 1.77 | 0.42 | 13.8 | 2.22 | 1.61 | 0.48 | 17.9 | 2.46 | 1.49 | 0.53 | 21.9 | |
| | 5 | 1.88 | 1.59 | 0.32 | 8.2 | 1.77 | / | 0.31 | 7.3 | 1.78 | 1.72 | 0.31 | 7.3 | 2.05 | 1.56 | 0.35 | 9.7 | 2.28 | 1.42 | 0.39 | 12.1 | |
| | 6 | 1.67 | 1.53 | 0.24 | 4.5 | 1.65 | / | 0.24 | 4.4 | 1.65 | 1.62 | 0.24 | 4.4 | 1.86 | 1.49 | 0.27 | 5.6 | 2.09 | 1.34 | 0.3 | 7.0 | |
| | 7 | 1.48 | / | 0.18 | 2.6 | 1.53 | / | 0.19 | 2.8 | 1.52 | / | 0.19 | 2.7 | 1.62 | 1.41 | 0.2 | 3.1 | 1.9 | 1.26 | 0.23 | 4.3 | |
| 13 | 3 | 1.94 | 1.63 | 0.56 | 24.2 | 1.8 | / | 0.51 | 20.8 | 1.83 | 1.76 | 0.52 | 21.5 | 2.11 | 1.6 | 0.6 | 28.6 | 2.36 | 1.47 | 0.68 | 35.7 | |
| | 4 | 1.77 | 1.56 | 0.38 | 11.4 | 1.71 | / | 0.37 | 10.6 | 1.71 | 1.68 | 0.37 | 10.6 | 1.94 | 1.56 | 0.42 | 13.6 | 2.19 | 1.4 | 0.47 | 17.3 | |
| | 5 | 1.58 | 1.55 | 0.27 | 5.8 | 1.6 | / | 0.27 | 5.9 | 1.6 | / | 0.28 | 5.9 | 1.77 | 1.48 | 0.3 | 7.3 | 2.01 | 1.33 | 0.35 | 9.4 | |
| | 6 | 1.44 | / | 0.21 | 3.3 | 1.49 | / | 0.21 | 3.6 | 1.49 | / | 0.21 | 3.6 | 1.56 | 1.43 | 0.22 | 3.9 | 1.82 | 1.26 | 0.26 | 5.3 | |
| | 7 | 1.32 | / | 0.16 | 2.1 | 1.36 | / | 0.17 | 2.2 | 1.37 | / | 0.17 | 2.2 | 1.37 | 1.34 | 0.17 | 2.2 | 1.59 | 1.19 | 0.2 | 3.0 | |

Cooling Capacity

| TKG-500 | | | | | | | | | | | | | | | | | | | | | | |
|---------|----|---------------------|------|------|-------|-------------|------|------|------|-------------|------|------|-------|-------------|------|------|-------|-------------|------|------|-------|--|
| EWT | Δt | Air inlet condition | | | | | | | | | | | | | | | | | | | | |
| | | DB:26.7 WB:19.4 | | | | DB:27 WB:18 | | | | DB:27 WB:19 | | | | DB:27 WB:20 | | | | DB:29 WB:21 | | | | |
| | | TC | SC | WF | WPD | TC | SC | WF | WPD | TC | SC | WF | WPD | TC | SC | WF | WPD | TC | SC | WF | WPD | |
| 5 | 3 | 5.19 | 3.12 | 1.49 | 117.3 | 4.76 | 3.44 | 1.36 | 98.7 | 5.08 | 3.26 | 1.46 | 112.5 | 5.37 | 3.12 | 1.54 | 125.9 | 5.67 | 2.98 | 1.63 | 140.3 | |
| | 4 | 4.99 | 3.03 | 1.07 | 61.0 | 4.58 | 3.33 | 0.98 | 51.5 | 4.9 | 3.17 | 1.05 | 59.0 | 5.19 | 3.03 | 1.12 | 66.1 | 5.45 | 2.88 | 1.17 | 72.9 | |
| | 5 | 4.77 | 2.92 | 0.82 | 35.7 | 4.36 | 3.25 | 0.75 | 29.9 | 4.67 | 3.07 | 0.8 | 34.3 | 4.99 | 2.92 | 0.86 | 39.0 | 5.24 | 4.53 | 0.9 | 43.1 | |
| | 6 | 4.56 | 2.84 | 0.65 | 22.6 | 4.15 | 3.14 | 0.6 | 18.8 | 4.47 | 2.96 | 0.64 | 21.8 | 4.78 | 2.81 | 0.69 | 24.9 | 5.01 | 2.67 | 0.72 | 27.4 | |
| | 7 | 4.33 | 2.71 | 0.53 | 15.0 | 3.92 | 3.07 | 0.48 | 12.3 | 4.23 | 2.86 | 0.52 | 14.4 | 4.55 | 2.71 | 0.56 | 16.6 | 4.8 | 2.56 | 0.59 | 18.4 | |
| 6 | 3 | 4.89 | 3 | 1.4 | 104.4 | 4.46 | 3.31 | 1.28 | 86.6 | 4.78 | 3.13 | 1.37 | 99.6 | 5.09 | 2.98 | 1.46 | 113.0 | 5.39 | 2.84 | 1.54 | 126.5 | |
| | 4 | 4.7 | 2.9 | 1.01 | 54.1 | 4.26 | 3.2 | 0.92 | 44.5 | 4.59 | 3.02 | 0.99 | 51.6 | 4.89 | 2.89 | 1.05 | 58.7 | 5.17 | 2.75 | 1.11 | 65.5 | |
| | 5 | 4.47 | 2.79 | 0.77 | 31.4 | 4.06 | 3.11 | 0.7 | 25.9 | 4.38 | 2.94 | 0.75 | 30.1 | 4.67 | 2.77 | 0.8 | 34.2 | 4.96 | 2.64 | 0.85 | 38.7 | |
| | 6 | 4.26 | 2.71 | 0.61 | 19.8 | 3.85 | 3.01 | 0.55 | 16.2 | 4.16 | 2.82 | 0.6 | 18.9 | 4.47 | 2.66 | 0.64 | 21.8 | 4.72 | 2.53 | 0.68 | 24.2 | |
| | 7 | 4.03 | 2.58 | 0.5 | 13.0 | 3.61 | 2.93 | 0.44 | 10.5 | 3.93 | 2.75 | 0.48 | 12.4 | 4.22 | 2.57 | 0.52 | 14.2 | 4.5 | 2.42 | 0.55 | 16.3 | |
| 7 | 3 | 4.57 | 2.85 | 1.31 | 91.0 | 4.15 | 3.18 | 1.19 | 75.0 | 4.47 | 3 | 1.28 | 87.1 | 4.8 | 2.85 | 1.38 | 100.4 | 5.07 | 2.7 | 1.45 | 112.0 | |
| | 4 | 4.38 | 2.75 | 0.94 | 47.1 | 3.93 | 3.11 | 0.84 | 37.9 | 4.26 | 2.9 | 0.92 | 44.6 | 4.58 | 2.75 | 0.98 | 51.5 | 4.87 | 2.61 | 1.05 | 58.1 | |
| | 5 | 4.16 | 2.65 | 0.72 | 27.1 | 3.73 | 3.01 | 0.64 | 21.8 | 4.07 | 2.8 | 0.7 | 26.0 | 4.36 | 2.63 | 0.75 | 29.9 | 4.63 | 2.51 | 0.8 | 33.7 | |
| | 6 | 3.94 | 2.58 | 0.56 | 16.9 | 3.51 | 2.91 | 0.5 | 13.4 | 3.87 | 2.7 | 0.55 | 16.3 | 4.16 | 2.53 | 0.6 | 18.9 | 4.42 | 2.4 | 0.63 | 21.3 | |
| | 7 | 3.73 | 2.46 | 0.46 | 11.1 | 3.28 | 2.81 | 0.4 | 8.6 | 3.61 | 2.62 | 0.44 | 10.4 | 3.92 | 2.45 | 0.48 | 12.3 | 4.19 | 2.3 | 0.51 | 14.0 | |
| 8 | 3 | 4.26 | 2.73 | 1.22 | 79.1 | 3.8 | 3.07 | 1.09 | 63.0 | 4.16 | 2.86 | 1.19 | 75.4 | 4.48 | 2.7 | 1.28 | 87.3 | 4.76 | 2.55 | 1.37 | 98.9 | |
| | 4 | 4.07 | 2.64 | 0.88 | 40.6 | 3.61 | 2.97 | 0.78 | 32.0 | 3.95 | 2.8 | 0.85 | 38.2 | 4.26 | 2.61 | 0.92 | 44.5 | 4.53 | 2.48 | 0.97 | 50.4 | |
| | 5 | 3.86 | 2.53 | 0.66 | 23.4 | 3.39 | 2.88 | 0.58 | 18.0 | 3.75 | 2.68 | 0.64 | 22.0 | 4.06 | 2.52 | 0.7 | 25.9 | 4.34 | 2.38 | 0.75 | 29.6 | |
| | 6 | 3.61 | 2.45 | 0.52 | 14.2 | 3.17 | 2.8 | 0.45 | 11.0 | 3.54 | 2.58 | 0.51 | 13.7 | 3.85 | 2.41 | 0.55 | 16.2 | 4.12 | 2.27 | 0.59 | 18.5 | |
| | 7 | 3.4 | 2.34 | 0.42 | 9.3 | 2.94 | 2.68 | 0.36 | 6.9 | 3.29 | 2.5 | 0.4 | 8.7 | 3.61 | 2.31 | 0.44 | 10.4 | 3.86 | 2.17 | 0.47 | 11.9 | |
| 9 | 3 | 3.96 | 2.61 | 1.13 | 68.3 | 3.48 | 2.95 | 1 | 52.9 | 3.85 | 2.74 | 1.1 | 64.5 | 4.18 | 2.57 | 1.2 | 76.0 | 4.45 | 2.43 | 1.27 | 86.2 | |
| | 4 | 3.74 | 2.51 | 0.8 | 34.2 | 3.28 | 2.86 | 0.7 | 26.3 | 3.62 | 2.65 | 0.78 | 32.2 | 3.93 | 2.5 | 0.85 | 38.0 | 4.22 | 2.34 | 0.91 | 43.6 | |
| | 5 | 3.54 | 2.41 | 0.61 | 19.6 | 3.03 | 2.8 | 0.52 | 14.4 | 3.42 | 2.57 | 0.59 | 18.4 | 3.73 | 2.39 | 0.64 | 21.8 | 4.01 | 2.24 | 0.69 | 25.3 | |
| | 6 | 3.3 | 2.32 | 0.47 | 11.9 | 2.8 | 2.71 | 0.4 | 8.6 | 3.18 | 2.48 | 0.46 | 11.0 | 3.52 | 2.28 | 0.51 | 13.5 | 3.8 | 2.13 | 0.54 | 15.7 | |
| | 7 | 3.05 | 2.21 | 0.38 | 7.5 | 2.61 | / | 0.32 | 5.5 | 2.95 | 2.37 | 0.36 | 7.0 | 3.27 | 2.21 | 0.4 | 8.5 | 3.54 | 2.04 | 0.43 | 10.0 | |
| 10 | 3 | 3.63 | 2.47 | 1.04 | 57.4 | 3.12 | 2.84 | 0.9 | 42.6 | 3.48 | 2.64 | 1 | 52.9 | 3.84 | 2.46 | 1.1 | 64.1 | 4.13 | 2.3 | 1.19 | 74.5 | |
| | 4 | 3.41 | 2.38 | 0.73 | 28.5 | 2.89 | 2.78 | 0.62 | 20.5 | 3.29 | 2.55 | 0.71 | 26.5 | 3.62 | 2.37 | 0.78 | 32.2 | 3.89 | 2.21 | 0.84 | 37.2 | |
| | 5 | 3.18 | 2.3 | 0.55 | 15.9 | 2.71 | / | 0.47 | 11.5 | 3.05 | 2.47 | 0.52 | 14.6 | 3.39 | 2.27 | 0.58 | 18.1 | 3.69 | 2.11 | 0.63 | 21.4 | |
| | 6 | 2.97 | 2.2 | 0.43 | 9.6 | 2.57 | / | 0.37 | 7.2 | 2.83 | 2.37 | 0.41 | 8.7 | 3.17 | 2.15 | 0.45 | 11.0 | 3.45 | 2.01 | 0.49 | 13.0 | |
| | 7 | 2.71 | 2.11 | 0.33 | 5.9 | 2.41 | / | 0.3 | 4.7 | 2.58 | 2.28 | 0.32 | 5.3 | 2.91 | 2.08 | 0.36 | 6.8 | 3.22 | 1.91 | 0.4 | 8.3 | |
| 11 | 3 | 3.28 | 2.36 | 0.94 | 46.8 | 2.78 | / | 0.8 | 33.7 | 3.16 | 2.51 | 0.91 | 43.5 | 3.49 | 2.35 | 1 | 53.1 | 3.8 | 2.18 | 1.09 | 63.0 | |
| | 4 | 3.07 | 2.28 | 0.66 | 23.1 | 2.64 | / | 0.57 | 17.1 | 2.95 | 2.42 | 0.63 | 21.3 | 3.28 | 2.24 | 0.71 | 26.4 | 3.59 | 2.09 | 0.77 | 31.6 | |
| | 5 | 2.84 | 2.19 | 0.49 | 12.6 | 2.51 | / | 0.43 | 9.9 | 2.71 | 2.36 | 0.47 | 11.5 | 3.05 | 2.14 | 0.53 | 14.6 | 3.35 | 1.99 | 0.58 | 17.7 | |
| | 6 | 2.58 | 2.1 | 0.37 | 7.3 | 2.36 | / | 0.34 | 6.1 | 2.48 | 2.26 | 0.36 | 6.7 | 2.82 | 2.07 | 0.4 | 8.7 | 3.11 | 1.89 | 0.45 | 10.6 | |
| | 7 | 2.3 | 2.03 | 0.28 | 4.2 | 2.22 | / | 0.27 | 4.0 | 2.22 | / | 0.27 | 4.0 | 2.55 | 1.97 | 0.31 | 5.2 | 2.87 | 1.78 | 0.35 | 6.6 | |
| 12 | 3 | 2.93 | 2.25 | 0.84 | 37.5 | 2.57 | / | 0.74 | 28.9 | 2.79 | 2.43 | 0.8 | 33.9 | 3.16 | 2.21 | 0.91 | 43.5 | 3.45 | 2.06 | 0.99 | 52.0 | |
| | 4 | 2.71 | 2.17 | 0.58 | 18.1 | 2.45 | / | 0.53 | 14.7 | 2.58 | 2.34 | 0.55 | 16.3 | 2.94 | 2.13 | 0.63 | 21.2 | 3.25 | 1.97 | 0.7 | 25.9 | |
| | 5 | 2.48 | 2.1 | 0.43 | 9.6 | 2.34 | / | 0.4 | 8.6 | 2.35 | 2.27 | 0.4 | 8.7 | 2.71 | 2.06 | 0.47 | 11.5 | 3.01 | 1.88 | 0.52 | 14.3 | |
| | 6 | 2.2 | 2.03 | 0.32 | 5.3 | 2.18 | / | 0.31 | 5.2 | 2.18 | 2.14 | 0.31 | 5.2 | 2.45 | 1.97 | 0.35 | 6.6 | 2.76 | 1.77 | 0.4 | 8.3 | |
| | 7 | 1.95 | / | 0.24 | 3.0 | 2.03 | / | 0.25 | 3.3 | 2.01 | / | 0.25 | 3.2 | 2.14 | 1.87 | 0.26 | 3.7 | 2.51 | 1.67 | 0.31 | 5.0 | |
| 13 | 3 | 2.56 | 2.15 | 0.73 | 28.6 | 2.37 | / | 0.68 | 24.6 | 2.41 | 2.33 | 0.69 | 25.4 | 2.78 | 2.11 | 0.8 | 33.8 | 3.11 | 1.94 | 0.89 | 42.2 | |
| | 4 | 2.34 | 2.07 | 0.5 | 13.5 | 2.26 | / | 0.49 | 12.5 | 2.26 | 2.22 | 0.49 | 12.5 | 2.56 | 2.06 | 0.55 | 16.1 | 2.89 | 1.85 | 0.62 | 20.5 | |
| | 5 | 2.09 | 2.04 | 0.36 | 6.9 | 2.11 | / | 0.36 | 7.0 | 2.11 | / | 0.36 | 7.0 | 2.34 | 1.96 | 0.4 | 8.6 | 2.66 | 1.76 | 0.46 | 11.1 | |
| | 6 | 1.9 | / | 0.27 | 4.0 | 1.97 | / | 0.28 | 4.2 | 1.97 | / | 0.28 | 4.2 | 2.06 | 1.89 | 0.3 | 4.6 | 2.4 | 1.67 | 0.34 | 6.3 | |
| | 7 | 1.74 | / | 0.21 | 2.4 | 1.8 | / | 0.22 | 2.6 | 1.81 | / | 0.22 | 2.6 | 1.81 | 1.77 | 0.22 | 2.6 | 2.1 | 1.57 | 0.26 | 3.5 | |

Cooling Capacity

| TKG-600 | | | | | | | | | | | | | | | | | | | | | | |
|---------|----|---------------------|------|------|-------|-------------|------|------|-------|-------------|------|------|-------|-------------|------|------|-------|-------------|------|------|-------|--|
| EWT | Δt | Air inlet condition | | | | | | | | | | | | | | | | | | | | |
| | | DB:26.7 WB:19.4 | | | | DB:27 WB:18 | | | | DB:27 WB:19 | | | | DB:27 WB:20 | | | | DB:29 WB:21 | | | | |
| | | TC | SC | WF | WPD | TC | SC | WF | WPD | TC | SC | WF | WPD | TC | SC | WF | WPD | TC | SC | WF | WPD | |
| 5 | 3 | 5.67 | 3.42 | 1.63 | 130.8 | 5.2 | 3.76 | 1.49 | 110.1 | 5.55 | 3.56 | 1.59 | 125.5 | 5.88 | 3.41 | 1.68 | 140.4 | 6.2 | 3.26 | 1.78 | 156.5 | |
| | 4 | 5.45 | 3.31 | 1.17 | 68.0 | 5.01 | 3.64 | 1.08 | 57.4 | 5.36 | 3.46 | 1.15 | 65.8 | 5.68 | 3.31 | 1.22 | 73.7 | 5.96 | 3.15 | 1.28 | 81.3 | |
| | 5 | 5.21 | 3.2 | 0.9 | 39.8 | 4.77 | 3.56 | 0.82 | 33.3 | 5.11 | 3.35 | 0.88 | 38.3 | 5.45 | 3.19 | 0.94 | 43.5 | 5.73 | 4.95 | 0.99 | 48.1 | |
| | 6 | 4.98 | 3.11 | 0.71 | 25.3 | 4.54 | 3.44 | 0.65 | 21.0 | 4.89 | 3.24 | 0.7 | 24.3 | 5.23 | 3.07 | 0.75 | 27.8 | 5.48 | 2.92 | 0.79 | 30.5 | |
| | 7 | 4.74 | 2.96 | 0.58 | 16.8 | 4.29 | 3.35 | 0.53 | 13.8 | 4.63 | 3.13 | 0.57 | 16.0 | 4.97 | 2.96 | 0.61 | 18.5 | 5.25 | 2.8 | 0.64 | 20.6 | |
| 6 | 3 | 5.35 | 3.28 | 1.53 | 116.4 | 4.87 | 3.62 | 1.4 | 96.6 | 5.23 | 3.42 | 1.5 | 111.1 | 5.57 | 3.26 | 1.6 | 126.1 | 5.89 | 3.11 | 1.69 | 141.1 | |
| | 4 | 5.14 | 3.17 | 1.1 | 60.4 | 4.66 | 3.5 | 1 | 49.6 | 5.02 | 3.31 | 1.08 | 57.6 | 5.35 | 3.16 | 1.15 | 65.5 | 5.65 | 3.01 | 1.21 | 73.1 | |
| | 5 | 4.89 | 3.05 | 0.84 | 35.0 | 4.44 | 3.4 | 0.76 | 28.9 | 4.79 | 3.21 | 0.82 | 33.6 | 5.1 | 3.02 | 0.88 | 38.2 | 5.43 | 2.89 | 0.93 | 43.1 | |
| | 6 | 4.66 | 2.96 | 0.67 | 22.0 | 4.21 | 3.29 | 0.6 | 18.1 | 4.55 | 3.09 | 0.65 | 21.0 | 4.89 | 2.91 | 0.7 | 24.3 | 5.16 | 2.76 | 0.74 | 27.0 | |
| | 7 | 4.41 | 2.83 | 0.54 | 14.5 | 3.95 | 3.2 | 0.49 | 11.7 | 4.3 | 3.01 | 0.53 | 13.8 | 4.61 | 2.81 | 0.57 | 15.9 | 4.93 | 2.65 | 0.61 | 18.1 | |
| 7 | 3 | 5 | 3.12 | 1.43 | 101.5 | 4.53 | 3.47 | 1.3 | 83.6 | 4.89 | 3.28 | 1.4 | 97.1 | 5.25 | 3.11 | 1.5 | 112.0 | 5.54 | 2.95 | 1.59 | 124.9 | |
| | 4 | 4.79 | 3.01 | 1.03 | 52.5 | 4.3 | 3.4 | 0.92 | 42.2 | 4.66 | 3.17 | 1 | 49.7 | 5.01 | 3.01 | 1.08 | 57.4 | 5.32 | 2.86 | 1.14 | 64.8 | |
| | 5 | 4.55 | 2.9 | 0.78 | 30.3 | 4.08 | 3.29 | 0.7 | 24.4 | 4.45 | 3.06 | 0.77 | 29.0 | 4.77 | 2.88 | 0.82 | 33.3 | 5.07 | 2.74 | 0.87 | 37.6 | |
| | 6 | 4.31 | 2.82 | 0.62 | 18.9 | 3.84 | 3.18 | 0.55 | 15.0 | 4.23 | 2.95 | 0.61 | 18.2 | 4.55 | 2.77 | 0.65 | 21.1 | 4.84 | 2.62 | 0.69 | 23.8 | |
| | 7 | 4.08 | 2.69 | 0.5 | 12.4 | 3.58 | 3.07 | 0.44 | 9.6 | 3.94 | 2.86 | 0.48 | 11.6 | 4.28 | 2.68 | 0.53 | 13.7 | 4.58 | 2.51 | 0.56 | 15.7 | |
| 8 | 3 | 4.66 | 2.99 | 1.33 | 88.2 | 4.15 | 3.35 | 1.19 | 70.2 | 4.55 | 3.13 | 1.3 | 84.1 | 4.89 | 2.95 | 1.4 | 97.4 | 5.21 | 2.79 | 1.49 | 110.3 | |
| | 4 | 4.45 | 2.88 | 0.96 | 45.3 | 3.95 | 3.24 | 0.85 | 35.7 | 4.32 | 3.06 | 0.93 | 42.6 | 4.66 | 2.86 | 1 | 49.6 | 4.96 | 2.71 | 1.07 | 56.2 | |
| | 5 | 4.23 | 2.76 | 0.73 | 26.1 | 3.71 | 3.15 | 0.64 | 20.1 | 4.1 | 2.93 | 0.7 | 24.6 | 4.44 | 2.75 | 0.76 | 28.9 | 4.75 | 2.6 | 0.82 | 33.0 | |
| | 6 | 3.95 | 2.68 | 0.57 | 15.9 | 3.47 | 3.06 | 0.5 | 12.2 | 3.87 | 2.83 | 0.55 | 15.3 | 4.21 | 2.63 | 0.6 | 18.1 | 4.51 | 2.48 | 0.65 | 20.7 | |
| | 7 | 3.72 | 2.56 | 0.46 | 10.3 | 3.22 | 2.93 | 0.4 | 7.7 | 3.6 | 2.73 | 0.44 | 9.7 | 3.94 | 2.53 | 0.48 | 11.6 | 4.22 | 2.38 | 0.52 | 13.3 | |
| 9 | 3 | 4.33 | 2.85 | 1.24 | 76.2 | 3.81 | 3.22 | 1.09 | 59.0 | 4.21 | 2.99 | 1.21 | 72.0 | 4.57 | 2.81 | 1.31 | 84.8 | 4.86 | 2.66 | 1.39 | 96.1 | |
| | 4 | 4.08 | 2.75 | 0.88 | 38.2 | 3.58 | 3.13 | 0.77 | 29.4 | 3.96 | 2.9 | 0.85 | 35.9 | 4.3 | 2.73 | 0.92 | 42.4 | 4.61 | 2.56 | 0.99 | 48.6 | |
| | 5 | 3.87 | 2.63 | 0.66 | 21.9 | 3.31 | 3.06 | 0.57 | 16.1 | 3.74 | 2.81 | 0.64 | 20.5 | 4.08 | 2.61 | 0.7 | 24.4 | 4.39 | 2.45 | 0.75 | 28.2 | |
| | 6 | 3.61 | 2.54 | 0.52 | 13.2 | 3.06 | 2.96 | 0.44 | 9.5 | 3.48 | 2.72 | 0.5 | 12.3 | 3.85 | 2.49 | 0.55 | 15.1 | 4.15 | 2.33 | 0.6 | 17.6 | |
| | 7 | 3.34 | 2.41 | 0.41 | 8.3 | 2.86 | / | 0.35 | 6.1 | 3.22 | 2.59 | 0.4 | 7.8 | 3.57 | 2.41 | 0.44 | 9.5 | 3.87 | 2.23 | 0.47 | 11.2 | |
| 10 | 3 | 3.97 | 2.7 | 1.14 | 64.1 | 3.42 | 3.1 | 0.98 | 47.5 | 3.81 | 2.88 | 1.09 | 59.0 | 4.19 | 2.69 | 1.2 | 71.5 | 4.52 | 2.52 | 1.3 | 83.1 | |
| | 4 | 3.72 | 2.6 | 0.8 | 31.7 | 3.16 | 3.04 | 0.68 | 22.8 | 3.6 | 2.79 | 0.77 | 29.6 | 3.96 | 2.59 | 0.85 | 35.9 | 4.26 | 2.42 | 0.92 | 41.5 | |
| | 5 | 3.48 | 2.52 | 0.6 | 17.7 | 2.96 | / | 0.51 | 12.8 | 3.33 | 2.7 | 0.57 | 16.3 | 3.71 | 2.49 | 0.64 | 20.2 | 4.03 | 2.31 | 0.69 | 23.8 | |
| | 6 | 3.24 | 2.41 | 0.46 | 10.7 | 2.81 | / | 0.4 | 8.0 | 3.1 | 2.59 | 0.44 | 9.7 | 3.47 | 2.35 | 0.5 | 12.2 | 3.77 | 2.2 | 0.54 | 14.5 | |
| | 7 | 2.96 | 2.31 | 0.36 | 6.6 | 2.64 | / | 0.32 | 5.2 | 2.82 | 2.5 | 0.35 | 5.9 | 3.18 | 2.28 | 0.39 | 7.6 | 3.53 | 2.09 | 0.43 | 9.3 | |
| 11 | 3 | 3.58 | 2.58 | 1.03 | 52.2 | 3.04 | / | 0.87 | 37.5 | 3.45 | 2.75 | 0.99 | 48.6 | 3.81 | 2.57 | 1.09 | 59.2 | 4.15 | 2.38 | 1.19 | 70.2 | |
| | 4 | 3.36 | 2.49 | 0.72 | 25.8 | 2.89 | / | 0.62 | 19.1 | 3.22 | 2.65 | 0.69 | 23.8 | 3.59 | 2.45 | 0.77 | 29.5 | 3.92 | 2.29 | 0.84 | 35.2 | |
| | 5 | 3.1 | 2.4 | 0.53 | 14.1 | 2.75 | / | 0.47 | 11.1 | 2.96 | 2.58 | 0.51 | 12.8 | 3.34 | 2.34 | 0.57 | 16.3 | 3.67 | 2.18 | 0.63 | 19.7 | |
| | 6 | 2.83 | 2.3 | 0.4 | 8.1 | 2.57 | / | 0.37 | 6.7 | 2.72 | 2.47 | 0.39 | 7.5 | 3.08 | 2.27 | 0.44 | 9.7 | 3.4 | 2.07 | 0.49 | 11.8 | |
| | 7 | 2.52 | 2.22 | 0.31 | 4.7 | 2.43 | / | 0.3 | 4.4 | 2.43 | / | 0.3 | 4.4 | 2.79 | 2.15 | 0.34 | 5.8 | 3.13 | 1.95 | 0.38 | 7.3 | |
| 12 | 3 | 3.2 | 2.46 | 0.92 | 41.8 | 2.81 | / | 0.81 | 32.2 | 3.05 | 2.65 | 0.87 | 37.9 | 3.45 | 2.42 | 0.99 | 48.6 | 3.78 | 2.25 | 1.08 | 58.0 | |
| | 4 | 2.97 | 2.38 | 0.64 | 20.1 | 2.68 | / | 0.58 | 16.4 | 2.82 | 2.56 | 0.61 | 18.2 | 3.21 | 2.33 | 0.69 | 23.6 | 3.55 | 2.15 | 0.76 | 28.9 | |
| | 5 | 2.71 | 2.29 | 0.47 | 10.8 | 2.56 | / | 0.44 | 9.6 | 2.57 | 2.48 | 0.44 | 9.7 | 2.96 | 2.25 | 0.51 | 12.8 | 3.29 | 2.05 | 0.57 | 15.9 | |
| | 6 | 2.41 | 2.22 | 0.35 | 5.9 | 2.38 | / | 0.34 | 5.8 | 2.38 | 2.34 | 0.34 | 5.8 | 2.68 | 2.15 | 0.38 | 7.3 | 3.02 | 1.94 | 0.43 | 9.3 | |
| | 7 | 2.13 | / | 0.26 | 3.4 | 2.22 | / | 0.27 | 3.7 | 2.2 | / | 0.27 | 3.6 | 2.34 | 2.04 | 0.29 | 4.1 | 2.74 | 1.82 | 0.34 | 5.6 | |
| 13 | 3 | 2.8 | 2.35 | 0.8 | 31.9 | 2.59 | / | 0.74 | 27.4 | 2.64 | 2.55 | 0.76 | 28.3 | 3.04 | 2.31 | 0.87 | 37.7 | 3.4 | 2.13 | 0.98 | 47.1 | |
| | 4 | 2.56 | 2.26 | 0.55 | 15.0 | 2.47 | / | 0.53 | 14.0 | 2.47 | 2.43 | 0.53 | 14.0 | 2.8 | 2.25 | 0.6 | 17.9 | 3.16 | 2.02 | 0.68 | 22.8 | |
| | 5 | 2.29 | 2.23 | 0.39 | 7.7 | 2.31 | / | 0.4 | 7.8 | 2.31 | / | 0.4 | 7.8 | 2.56 | 2.14 | 0.44 | 9.6 | 2.91 | 1.93 | 0.5 | 12.4 | |
| | 6 | 2.08 | / | 0.3 | 4.4 | 2.15 | / | 0.31 | 4.7 | 2.15 | / | 0.31 | 4.7 | 2.25 | 2.06 | 0.32 | 5.2 | 2.63 | 1.82 | 0.38 | 7.0 | |
| | 7 | 1.9 | / | 0.23 | 2.7 | 1.97 | / | 0.24 | 2.9 | 1.98 | / | 0.24 | 2.9 | 1.98 | 1.93 | 0.24 | 2.9 | 2.3 | 1.72 | 0.28 | 4.0 | |

Cooling capacity modification coefficient table:

| Speed | 250 | | 300 | | 400 | | 500 | | 600 | |
|-------|------|------|------|------|------|------|------|------|------|------|
| | TC | SC | TC | SC | TC | SC | TC | SC | TC | SC |
| High | 1 | 1 | 1 | 1 | 1 | 1 | 1 | 1 | 1 | 1 |
| Mid | 0.84 | 0.81 | 0.85 | 0.82 | 0.85 | 0.83 | 0.92 | 0.88 | 0.94 | 0.9 |
| Low | 0.75 | 0.72 | 0.78 | 0.75 | 0.74 | 0.71 | 0.80 | 0.77 | 0.84 | 0.81 |

C panel Heating Capacity

Δt: Temperature Difference (°C) **TH:** Total Heating Capacity (kW) **WF:** Water Flow (m³/h) **WPD:** Water Pressure Drop (kPa)

| TKG-250 | | | | | | | | | | | | | | | | | | | | | | | | | |
|----------------|--|---------------------------|------|-----|------|------|------|------|------|------|------|------|------|------|------|------|------|------|------|------|------|------|-------|------|-------|
| Δt | | Air inlet temp. (20°C DB) | | | | | | | | | | | | | | | | | | | | | | | |
| | | Water inlet temp. (°C) | | | | | | | | | | | | | | | | | | | | | | | |
| | | 35 | | | 40 | | | 45 | | | 50 | | | 55 | | | 60 | | | 65 | | | 70 | | |
| | | TH | WF | WPD | TH | WF | WPD | TH | WF | WPD | TH | WF | WPD | TH | WF | WPD | TH | WF | WPD | TH | WF | WPD | TH | WF | WPD |
| 10 | | 1.00 | 0.09 | 0.6 | 1.57 | 0.14 | 1.5 | 2.18 | 0.19 | 2.8 | 2.75 | 0.24 | 4.4 | 3.32 | 0.29 | 6.5 | 3.91 | 0.34 | 9.0 | 4.47 | 0.38 | 11.7 | 5.03 | 0.43 | 14.9 |
| 8 | | 1.11 | 0.12 | 1.1 | 1.73 | 0.19 | 2.8 | 2.32 | 0.25 | 4.9 | 2.89 | 0.31 | 7.7 | 3.45 | 0.37 | 10.9 | 4.01 | 0.43 | 14.8 | 4.58 | 0.49 | 19.2 | 5.14 | 0.55 | 24.2 |
| 6 | | 1.29 | 0.18 | 2.7 | 1.88 | 0.27 | 5.7 | 2.43 | 0.35 | 9.6 | 3.10 | 0.43 | 14.9 | 3.59 | 0.51 | 21.0 | 4.15 | 0.60 | 28.1 | 4.68 | 0.67 | 35.7 | 5.28 | 0.76 | 45.4 |
| TKG-300 | | | | | | | | | | | | | | | | | | | | | | | | | |
| Δt | | Air inlet temp. (20°C DB) | | | | | | | | | | | | | | | | | | | | | | | |
| | | Water inlet temp. (°C) | | | | | | | | | | | | | | | | | | | | | | | |
| | | 35 | | | 40 | | | 45 | | | 50 | | | 55 | | | 60 | | | 65 | | | 70 | | |
| | | TH | WF | WPD | TH | WF | WPD | TH | WF | WPD | TH | WF | WPD | TH | WF | WPD | TH | WF | WPD | TH | WF | WPD | TH | WF | WPD |
| 10 | | 1.22 | 0.11 | 1.0 | 1.92 | 0.16 | 2.4 | 2.65 | 0.23 | 4.5 | 3.35 | 0.29 | 7.2 | 4.05 | 0.35 | 10.6 | 4.76 | 0.41 | 14.6 | 5.45 | 0.47 | 19.1 | 6.13 | 0.53 | 24.2 |
| 8 | | 1.36 | 0.15 | 1.8 | 2.11 | 0.23 | 4.5 | 2.83 | 0.30 | 8.0 | 3.53 | 0.38 | 12.5 | 4.20 | 0.45 | 17.8 | 4.89 | 0.53 | 24.1 | 5.58 | 0.60 | 31.3 | 6.26 | 0.67 | 39.5 |
| 6 | | 1.57 | 0.23 | 4.4 | 2.29 | 0.33 | 9.4 | 2.96 | 0.42 | 15.7 | 3.78 | 0.53 | 24.2 | 4.37 | 0.63 | 34.2 | 5.06 | 0.73 | 45.8 | 5.70 | 0.82 | 58.2 | 6.43 | 0.92 | 74.1 |
| TKG-400 | | | | | | | | | | | | | | | | | | | | | | | | | |
| Δt | | Air inlet temp. (20°C DB) | | | | | | | | | | | | | | | | | | | | | | | |
| | | Water inlet temp. (°C) | | | | | | | | | | | | | | | | | | | | | | | |
| | | 35 | | | 40 | | | 45 | | | 50 | | | 55 | | | 60 | | | 65 | | | 70 | | |
| | | TH | WF | WPD | TH | WF | WPD | TH | WF | WPD | TH | WF | WPD | TH | WF | WPD | TH | WF | WPD | TH | WF | WPD | TH | WF | WPD |
| 10 | | 1.44 | 0.12 | 1.2 | 2.26 | 0.19 | 2.9 | 3.13 | 0.27 | 5.6 | 3.95 | 0.34 | 8.9 | 4.78 | 0.41 | 12.9 | 5.61 | 0.48 | 17.9 | 6.42 | 0.55 | 23.4 | 7.23 | 0.62 | 29.7 |
| 8 | | 1.60 | 0.17 | 2.3 | 2.49 | 0.27 | 5.5 | 3.33 | 0.36 | 9.8 | 4.16 | 0.45 | 15.3 | 4.96 | 0.53 | 21.8 | 5.77 | 0.62 | 29.5 | 6.58 | 0.71 | 38.3 | 7.39 | 0.79 | 48.3 |
| 6 | | 1.85 | 0.27 | 5.4 | 2.70 | 0.39 | 11.4 | 3.50 | 0.50 | 19.2 | 4.41 | 0.62 | 29.7 | 5.16 | 0.74 | 41.9 | 5.97 | 0.86 | 56.1 | 6.73 | 0.96 | 71.3 | 7.59 | 1.09 | 90.7 |
| TKG-500 | | | | | | | | | | | | | | | | | | | | | | | | | |
| Δt | | Air inlet temp. (20°C DB) | | | | | | | | | | | | | | | | | | | | | | | |
| | | Water inlet temp. (°C) | | | | | | | | | | | | | | | | | | | | | | | |
| | | 35 | | | 40 | | | 45 | | | 50 | | | 55 | | | 60 | | | 65 | | | 70 | | |
| | | TH | WF | WPD | TH | WF | WPD | TH | WF | WPD | TH | WF | WPD | TH | WF | WPD | TH | WF | WPD | TH | WF | WPD | TH | WF | WPD |
| 10 | | 1.89 | 0.16 | 1.4 | 2.96 | 0.25 | 3.4 | 4.11 | 0.35 | 6.6 | 5.18 | 0.45 | 10.4 | 6.26 | 0.54 | 15.3 | 7.36 | 0.63 | 21.1 | 8.42 | 0.72 | 27.6 | 9.48 | 0.82 | 35.0 |
| 8 | | 2.10 | 0.23 | 2.7 | 3.26 | 0.35 | 6.5 | 4.37 | 0.47 | 11.6 | 5.45 | 0.59 | 18.1 | 6.50 | 0.70 | 25.7 | 7.56 | 0.81 | 34.8 | 8.62 | 0.93 | 45.2 | 9.68 | 1.04 | 57.0 |
| 6 | | 2.43 | 0.35 | 6.4 | 3.53 | 0.51 | 13.5 | 4.58 | 0.66 | 22.7 | 5.75 | 0.82 | 35.0 | 6.76 | 0.97 | 49.5 | 7.83 | 1.12 | 66.2 | 8.82 | 1.26 | 84.1 | 9.95 | 1.43 | 107.0 |
| TKG-600 | | | | | | | | | | | | | | | | | | | | | | | | | |
| Δt | | Air inlet temp. (20°C DB) | | | | | | | | | | | | | | | | | | | | | | | |
| | | Water inlet temp. (°C) | | | | | | | | | | | | | | | | | | | | | | | |
| | | 35 | | | 40 | | | 45 | | | 50 | | | 55 | | | 60 | | | 65 | | | 70 | | |
| | | TH | WF | WPD | TH | WF | WPD | TH | WF | WPD | TH | WF | WPD | TH | WF | WPD | TH | WF | WPD | TH | WF | WPD | TH | WF | WPD |
| 10 | | 2.09 | 0.18 | 1.5 | 3.28 | 0.28 | 3.8 | 4.55 | 0.39 | 7.3 | 5.73 | 0.49 | 11.6 | 6.93 | 0.60 | 17.0 | 8.15 | 0.70 | 23.5 | 9.33 | 0.80 | 30.8 | 10.50 | 0.90 | 39.0 |
| 8 | | 2.32 | 0.25 | 3.0 | 3.61 | 0.39 | 7.2 | 4.84 | 0.52 | 12.9 | 6.04 | 0.65 | 20.1 | 7.20 | 0.77 | 28.6 | 8.37 | 0.90 | 38.7 | 9.55 | 1.03 | 50.4 | 10.72 | 1.15 | 63.5 |
| 6 | | 2.69 | 0.39 | 7.1 | 3.91 | 0.56 | 15.1 | 5.07 | 0.73 | 25.3 | 6.38 | 0.90 | 39.0 | 7.49 | 1.07 | 55.1 | 8.66 | 1.24 | 73.8 | 9.77 | 1.40 | 93.7 | 11.01 | 1.58 | 119.2 |

Heating capacity modification coefficient table:

| Speed | 250 | 300 | 400 | 500 | 600 |
|-------|------|------|------|------|------|
| | TH | TH | TH | TH | TH |
| High | 1 | 1 | 1 | 1 | 1 |
| Mid | 0.86 | 0.88 | 0.89 | 0.90 | 0.90 |
| Low | 0.74 | 0.75 | 0.75 | 0.76 | 0.75 |

Altitude modification coefficient table:

| Altitude | TC | SC | TH |
|----------|------|------|------|
| 500 | 0.98 | 0.95 | 0.95 |
| 1000 | 0.97 | 0.91 | 0.91 |
| 1500 | 0.95 | 0.86 | 0.86 |
| 2000 | 0.94 | 0.82 | 0.82 |
| 2500 | 0.93 | 0.78 | 0.78 |
| 3000 | 0.91 | 0.74 | 0.70 |

S panel Cooling Capacity

EWT: Enter Water Temp. (°C) **Δt:** Temperature Difference (°C) **DB:** Dry Bulb Temp. (°C) **WB:** Wet Bulb Temp. (°C)

TC: Total Cooling Capacity (kW) **SC:** Sensible Cooling Capacity (kW) **WF:** Water Flow (m³/h) **WPD:** Water Pressure Drop (kPa)

| TKG-250-B | | | | | | | | | | | | | | | | | | | | | |
|-----------|----|---------------------|------|------|------|-----------------|------|------|-------|-------------|------|------|-------|-------------|------|------|-------|-------------|------|------|-------|
| EWT | Δt | Air inlet condition | | | | | | | | | | | | | | | | | | | |
| | | DB:21 WB:15 | | | | DB:26.7 WB:19.4 | | | | DB:27 WB:19 | | | | DB:29 WB:21 | | | | DB:33 WB:25 | | | |
| | | TC | SC | WF | WPD | TC | SC | WF | WPD | TC | SC | WF | WPD | TC | SC | WF | WPD | TC | SC | WF | WPD |
| 5 | 3 | 2.17 | 1.58 | 0.62 | 55.8 | 3.35 | 2.02 | 0.96 | 132.6 | 3.28 | 2.11 | 0.94 | 127.2 | 3.67 | 1.92 | 1.05 | 158.7 | 4.93 | 2.39 | 1.41 | 287.4 |
| | 4 | 2.05 | 1.49 | 0.44 | 27.8 | 3.22 | 1.96 | 0.69 | 68.9 | 3.17 | 2.05 | 0.68 | 66.7 | 3.52 | 1.86 | 0.76 | 82.4 | 4.78 | 2.32 | 1.03 | 151.9 |
| | 5 | 1.89 | 1.43 | 0.33 | 15.2 | 3.08 | 1.89 | 0.53 | 40.4 | 3.02 | 1.98 | 0.52 | 38.8 | 3.39 | 2.93 | 0.58 | 48.7 | 4.63 | 2.28 | 0.80 | 91.1 |
| | 6 | 1.73 | 1.37 | 0.25 | 8.8 | 2.94 | 1.84 | 0.42 | 25.6 | 2.89 | 1.91 | 0.41 | 24.6 | 3.24 | 1.72 | 0.46 | 30.9 | 4.52 | 2.20 | 0.65 | 60.2 |
| | 7 | 1.55 | 1.28 | 0.19 | 5.2 | 2.80 | 1.75 | 0.34 | 17.0 | 2.74 | 1.85 | 0.34 | 16.2 | 3.10 | 1.65 | 0.38 | 20.8 | 4.36 | 2.13 | 0.54 | 41.3 |
| 6 | 3 | 1.97 | 1.49 | 0.56 | 45.6 | 3.16 | 1.94 | 0.91 | 118.0 | 3.09 | 2.02 | 0.89 | 112.7 | 3.48 | 1.84 | 1.00 | 143.0 | 4.74 | 2.32 | 1.36 | 265.7 |
| | 4 | 1.83 | 1.42 | 0.39 | 22.1 | 3.04 | 1.87 | 0.65 | 61.2 | 2.96 | 1.95 | 0.64 | 58.3 | 3.34 | 1.78 | 0.72 | 74.1 | 4.59 | 2.24 | 0.99 | 140.0 |
| | 5 | 1.69 | 1.35 | 0.29 | 12.1 | 2.89 | 1.80 | 0.50 | 35.5 | 2.83 | 1.90 | 0.49 | 34.1 | 3.21 | 1.71 | 0.55 | 43.7 | 4.44 | 2.16 | 0.76 | 83.8 |
| | 6 | 1.51 | 1.29 | 0.22 | 6.8 | 2.75 | 1.75 | 0.39 | 22.3 | 2.69 | 1.83 | 0.39 | 21.3 | 3.05 | 1.63 | 0.44 | 27.4 | 4.33 | 2.09 | 0.62 | 55.2 |
| | 7 | 1.33 | 1.20 | 0.16 | 3.8 | 2.61 | 1.67 | 0.32 | 14.7 | 2.54 | 1.78 | 0.31 | 14.0 | 2.91 | 1.56 | 0.36 | 18.4 | 4.17 | 2.05 | 0.51 | 37.8 |
| 7 | 3 | 1.76 | 1.40 | 0.50 | 36.5 | 2.95 | 1.84 | 0.85 | 102.9 | 2.89 | 1.94 | 0.83 | 98.5 | 3.28 | 1.75 | 0.94 | 126.6 | 4.52 | 2.20 | 1.29 | 240.8 |
| | 4 | 1.61 | 1.34 | 0.35 | 17.3 | 2.83 | 1.78 | 0.61 | 53.2 | 2.76 | 1.87 | 0.59 | 50.4 | 3.15 | 1.69 | 0.68 | 65.7 | 4.40 | 2.16 | 0.95 | 128.7 |
| | 5 | 1.46 | 1.28 | 0.25 | 9.0 | 2.69 | 1.72 | 0.46 | 30.7 | 2.63 | 1.81 | 0.45 | 29.4 | 2.99 | 1.62 | 0.52 | 38.1 | 4.25 | 2.09 | 0.73 | 76.8 |
| | 6 | 1.28 | 1.21 | 0.18 | 4.9 | 2.55 | 1.67 | 0.36 | 19.1 | 2.50 | 1.75 | 0.36 | 18.5 | 2.86 | 1.55 | 0.41 | 24.1 | 4.14 | 2.01 | 0.59 | 50.5 |
| | 7 | 1.11 | 1.11 | 0.14 | 2.7 | 2.41 | 1.59 | 0.30 | 12.6 | 2.33 | 1.69 | 0.29 | 11.8 | 2.71 | 1.48 | 0.33 | 15.9 | 3.98 | 1.94 | 0.49 | 34.4 |
| 8 | 3 | 1.54 | 1.32 | 0.44 | 28.0 | 2.75 | 1.76 | 0.79 | 89.4 | 2.69 | 1.85 | 0.77 | 85.2 | 3.08 | 1.65 | 0.88 | 111.8 | 4.33 | 2.13 | 1.24 | 221.0 |
| | 4 | 1.39 | 1.28 | 0.30 | 12.8 | 2.63 | 1.70 | 0.57 | 45.9 | 2.55 | 1.81 | 0.55 | 43.2 | 2.93 | 1.60 | 0.63 | 57.0 | 4.17 | 2.05 | 0.90 | 115.7 |
| | 5 | 1.23 | 1.20 | 0.21 | 6.4 | 2.50 | 1.63 | 0.43 | 26.5 | 2.42 | 1.73 | 0.42 | 24.9 | 2.80 | 1.54 | 0.48 | 33.4 | 4.06 | 1.97 | 0.70 | 70.1 |
| | 6 | 1.10 | 1.10 | 0.16 | 3.6 | 2.33 | 1.58 | 0.33 | 16.1 | 2.29 | 1.67 | 0.33 | 15.5 | 2.66 | 1.46 | 0.38 | 21.0 | 3.91 | 1.94 | 0.56 | 45.1 |
| | 7 | 0.96 | 0.96 | 0.12 | 2.0 | 2.20 | 1.51 | 0.27 | 10.5 | 2.13 | 1.61 | 0.26 | 9.8 | 2.49 | 1.40 | 0.31 | 13.5 | 3.77 | 1.86 | 0.46 | 30.9 |
| 9 | 3 | 1.32 | 1.25 | 0.38 | 20.5 | 2.56 | 1.69 | 0.73 | 77.2 | 2.49 | 1.77 | 0.71 | 73.0 | 2.87 | 1.57 | 0.82 | 97.4 | 4.14 | 2.05 | 1.19 | 202.0 |
| | 4 | 1.20 | 1.20 | 0.26 | 9.5 | 2.41 | 1.62 | 0.52 | 38.7 | 2.34 | 1.72 | 0.50 | 36.4 | 2.72 | 1.51 | 0.59 | 49.3 | 3.98 | 1.97 | 0.86 | 105.5 |
| | 5 | 1.10 | 1.07 | 0.19 | 5.2 | 2.28 | 1.56 | 0.39 | 22.2 | 2.21 | 1.66 | 0.38 | 20.8 | 2.59 | 1.45 | 0.45 | 28.6 | 3.87 | 1.90 | 0.67 | 63.7 |
| | 6 | 0.97 | 0.97 | 0.14 | 2.8 | 2.13 | 1.50 | 0.31 | 13.4 | 2.06 | 1.61 | 0.29 | 12.5 | 2.46 | 1.38 | 0.35 | 17.8 | 3.71 | 1.86 | 0.53 | 40.6 |
| | 7 | 0.79 | 0.79 | 0.10 | 1.4 | 1.97 | 1.43 | 0.24 | 8.4 | 1.91 | 1.53 | 0.23 | 7.9 | 2.28 | 1.32 | 0.28 | 11.3 | 3.58 | 1.79 | 0.44 | 27.8 |
| 10 | 3 | 1.16 | 1.16 | 0.33 | 15.9 | 2.35 | 1.60 | 0.67 | 64.9 | 2.25 | 1.70 | 0.65 | 59.8 | 2.67 | 1.49 | 0.77 | 84.3 | 3.95 | 1.94 | 1.13 | 183.9 |
| | 4 | 1.07 | 1.07 | 0.23 | 7.6 | 2.20 | 1.54 | 0.47 | 32.2 | 2.13 | 1.65 | 0.46 | 30.0 | 2.52 | 1.43 | 0.54 | 42.0 | 3.78 | 1.90 | 0.81 | 95.1 |
| | 5 | 0.95 | 0.95 | 0.16 | 3.9 | 2.06 | 1.49 | 0.35 | 18.0 | 1.97 | 1.59 | 0.34 | 16.5 | 2.38 | 1.37 | 0.41 | 24.1 | 3.67 | 1.83 | 0.63 | 57.1 |
| | 6 | 0.82 | 0.82 | 0.12 | 2.0 | 1.92 | 1.42 | 0.27 | 10.8 | 1.83 | 1.53 | 0.26 | 9.9 | 2.23 | 1.30 | 0.32 | 14.6 | 3.51 | 1.78 | 0.50 | 36.3 |
| | 7 | 0.52 | 0.52 | 0.06 | 0.6 | 1.75 | 1.36 | 0.21 | 6.6 | 1.67 | 1.48 | 0.20 | 6.0 | 2.08 | 1.23 | 0.26 | 9.4 | 3.35 | 1.71 | 0.41 | 24.4 |
| 11 | 3 | 1.02 | 1.02 | 0.29 | 12.4 | 2.12 | 1.53 | 0.61 | 52.9 | 2.04 | 1.62 | 0.59 | 49.2 | 2.46 | 1.41 | 0.70 | 71.2 | 3.72 | 1.86 | 1.07 | 163.7 |
| | 4 | 0.94 | 0.94 | 0.20 | 5.8 | 1.98 | 1.47 | 0.43 | 26.2 | 1.91 | 1.56 | 0.41 | 24.1 | 2.32 | 1.35 | 0.50 | 35.7 | 3.57 | 1.81 | 0.77 | 84.7 |
| | 5 | 0.81 | 0.81 | 0.14 | 2.8 | 1.83 | 1.42 | 0.32 | 14.3 | 1.75 | 1.53 | 0.30 | 13.0 | 2.17 | 1.29 | 0.37 | 20.0 | 3.46 | 1.75 | 0.59 | 50.8 |
| | 6 | 0.65 | 0.65 | 0.09 | 1.2 | 1.67 | 1.36 | 0.24 | 8.2 | 1.61 | 1.46 | 0.23 | 7.6 | 2.01 | 1.22 | 0.29 | 11.9 | 3.30 | 1.70 | 0.47 | 32.1 |
| | 7 | 0.44 | 0.44 | 0.05 | 0.4 | 1.49 | 1.31 | 0.18 | 4.8 | 1.43 | 1.43 | 0.18 | 4.5 | 1.85 | 1.15 | 0.23 | 7.4 | 3.15 | 1.63 | 0.39 | 21.5 |
| 12 | 3 | 0.90 | 0.90 | 0.26 | 9.6 | 1.89 | 1.45 | 0.54 | 42.3 | 1.80 | 1.57 | 0.52 | 38.4 | 2.23 | 1.33 | 0.64 | 58.8 | 3.51 | 1.79 | 1.01 | 145.8 |
| | 4 | 0.80 | 0.80 | 0.17 | 4.2 | 1.75 | 1.40 | 0.38 | 20.4 | 1.67 | 1.51 | 0.36 | 18.4 | 2.10 | 1.27 | 0.45 | 29.3 | 3.37 | 1.73 | 0.72 | 75.3 |
| | 5 | 0.69 | 0.69 | 0.12 | 2.0 | 1.60 | 1.35 | 0.28 | 10.9 | 1.52 | 1.46 | 0.26 | 9.8 | 1.95 | 1.21 | 0.33 | 16.1 | 3.24 | 1.67 | 0.56 | 44.5 |
| | 6 | 0.41 | 0.41 | 0.06 | 0.5 | 1.42 | 1.31 | 0.20 | 6.0 | 1.41 | 1.38 | 0.20 | 5.9 | 1.78 | 1.15 | 0.26 | 9.4 | 3.08 | 1.62 | 0.44 | 28.0 |
| | 7 | 0.34 | 0.34 | 0.04 | 0.3 | 1.26 | 1.26 | 0.15 | 3.4 | 1.30 | 1.30 | 0.16 | 3.7 | 1.62 | 1.08 | 0.20 | 5.7 | 2.93 | 1.56 | 0.36 | 18.6 |
| 13 | 3 | 0.78 | 0.78 | 0.22 | 7.1 | 1.65 | 1.39 | 0.47 | 32.3 | 1.56 | 1.51 | 0.45 | 28.7 | 2.01 | 1.26 | 0.58 | 47.8 | 3.29 | 1.72 | 0.94 | 127.8 |
| | 4 | 0.66 | 0.66 | 0.14 | 2.9 | 1.51 | 1.34 | 0.33 | 15.2 | 1.46 | 1.43 | 0.31 | 14.2 | 1.87 | 1.20 | 0.40 | 23.2 | 3.15 | 1.65 | 0.68 | 65.9 |
| | 5 | 0.48 | 0.48 | 0.08 | 1.0 | 1.35 | 1.32 | 0.23 | 7.8 | 1.37 | 1.37 | 0.23 | 7.9 | 1.72 | 1.14 | 0.30 | 12.6 | 3.01 | 1.59 | 0.52 | 38.5 |
| | 6 | 0.32 | 0.32 | 0.05 | 0.3 | 1.23 | 1.23 | 0.18 | 4.5 | 1.27 | 1.27 | 0.18 | 4.8 | 1.55 | 1.08 | 0.22 | 7.1 | 2.85 | 1.55 | 0.41 | 24.0 |
| | 7 | 0.24 | 0.24 | 0.03 | 0.1 | 1.12 | 1.12 | 0.14 | 2.7 | 1.17 | 1.17 | 0.14 | 3.0 | 1.36 | 1.02 | 0.17 | 4.0 | 2.71 | 1.48 | 0.33 | 15.9 |

Cooling Capacity

| TKG-300-B | | | | | | | | | | | | | | | | | | | | | |
|-----------|----|---------------------|------|------|------|-----------------|------|------|-------|-------------|------|------|-------|-------------|------|------|-------|-------------|------|------|-------|
| EWT | Δt | Air inlet condition | | | | | | | | | | | | | | | | | | | |
| | | DB:21 WB:15 | | | | DB:26.7 WB:19.4 | | | | DB:27 WB:19 | | | | DB:29 WB:21 | | | | DB:33 WB:25 | | | |
| | | TC | SC | WF | WPD | TC | SC | WF | WPD | TC | SC | WF | WPD | TC | SC | WF | WPD | TC | SC | WF | WPD |
| 5 | 3 | 2.46 | 1.78 | 0.70 | 67.6 | 3.78 | 2.28 | 1.08 | 160.5 | 3.71 | 2.38 | 1.06 | 154.1 | 4.14 | 2.17 | 1.19 | 192.1 | 5.57 | 2.70 | 1.60 | 348.0 |
| | 4 | 2.31 | 1.68 | 0.50 | 33.6 | 3.64 | 2.21 | 0.78 | 83.5 | 3.58 | 2.31 | 0.77 | 80.8 | 3.98 | 2.10 | 0.86 | 99.7 | 5.40 | 2.61 | 1.16 | 183.9 |
| | 5 | 2.13 | 1.61 | 0.37 | 18.4 | 3.48 | 2.13 | 0.60 | 48.9 | 3.41 | 2.24 | 0.59 | 47.0 | 3.82 | 3.30 | 0.66 | 59.0 | 5.23 | 2.57 | 0.90 | 110.3 |
| | 6 | 1.95 | 1.54 | 0.28 | 10.7 | 3.33 | 2.07 | 0.48 | 31.0 | 3.26 | 2.16 | 0.47 | 29.8 | 3.66 | 1.95 | 0.52 | 37.5 | 5.10 | 2.49 | 0.73 | 72.9 |
| | 7 | 1.75 | 1.44 | 0.21 | 6.3 | 3.16 | 1.98 | 0.39 | 20.6 | 3.09 | 2.09 | 0.38 | 19.7 | 3.50 | 1.87 | 0.43 | 25.2 | 4.93 | 2.40 | 0.61 | 50.0 |
| 6 | 3 | 2.22 | 1.68 | 0.64 | 55.3 | 3.57 | 2.19 | 1.02 | 142.9 | 3.49 | 2.28 | 1.00 | 136.4 | 3.93 | 2.07 | 1.13 | 173.1 | 5.36 | 2.61 | 1.54 | 321.7 |
| | 4 | 2.06 | 1.60 | 0.44 | 26.8 | 3.43 | 2.11 | 0.74 | 74.1 | 3.35 | 2.21 | 0.72 | 70.6 | 3.77 | 2.01 | 0.81 | 89.7 | 5.19 | 2.53 | 1.11 | 169.6 |
| | 5 | 1.90 | 1.53 | 0.33 | 14.6 | 3.26 | 2.04 | 0.56 | 42.9 | 3.20 | 2.14 | 0.55 | 41.3 | 3.62 | 1.93 | 0.62 | 52.9 | 5.01 | 2.44 | 0.86 | 101.5 |
| | 6 | 1.71 | 1.46 | 0.25 | 8.2 | 3.11 | 1.98 | 0.45 | 27.1 | 3.03 | 2.06 | 0.43 | 25.8 | 3.44 | 1.84 | 0.49 | 33.2 | 4.89 | 2.36 | 0.70 | 66.9 |
| | 7 | 1.50 | 1.35 | 0.18 | 4.7 | 2.94 | 1.89 | 0.36 | 17.9 | 2.87 | 2.01 | 0.35 | 17.0 | 3.29 | 1.77 | 0.40 | 22.2 | 4.71 | 2.31 | 0.58 | 45.8 |
| 7 | 3 | 1.98 | 1.58 | 0.57 | 44.1 | 3.33 | 2.08 | 0.96 | 124.6 | 3.26 | 2.19 | 0.93 | 119.2 | 3.70 | 1.97 | 1.06 | 153.4 | 5.10 | 2.49 | 1.46 | 291.6 |
| | 4 | 1.82 | 1.52 | 0.39 | 20.9 | 3.20 | 2.01 | 0.69 | 64.5 | 3.11 | 2.12 | 0.67 | 61.0 | 3.55 | 1.91 | 0.76 | 79.6 | 4.97 | 2.44 | 1.07 | 155.9 |
| | 5 | 1.65 | 1.44 | 0.28 | 10.9 | 3.03 | 1.94 | 0.52 | 37.2 | 2.97 | 2.04 | 0.51 | 35.6 | 3.38 | 1.83 | 0.58 | 46.1 | 4.80 | 2.36 | 0.83 | 93.0 |
| | 6 | 1.45 | 1.37 | 0.21 | 5.9 | 2.88 | 1.88 | 0.41 | 23.2 | 2.82 | 1.97 | 0.40 | 22.4 | 3.23 | 1.75 | 0.46 | 29.2 | 4.67 | 2.27 | 0.67 | 61.2 |
| | 7 | 1.26 | 1.26 | 0.15 | 3.2 | 2.72 | 1.80 | 0.33 | 15.3 | 2.63 | 1.91 | 0.32 | 14.3 | 3.06 | 1.68 | 0.38 | 19.2 | 4.50 | 2.19 | 0.55 | 41.7 |
| 8 | 3 | 1.74 | 1.50 | 0.50 | 33.9 | 3.11 | 1.99 | 0.89 | 108.2 | 3.03 | 2.09 | 0.87 | 103.2 | 3.48 | 1.86 | 1.00 | 135.4 | 4.89 | 2.40 | 1.40 | 267.6 |
| | 4 | 1.57 | 1.45 | 0.34 | 15.5 | 2.97 | 1.92 | 0.64 | 55.6 | 2.88 | 2.04 | 0.62 | 52.3 | 3.31 | 1.81 | 0.71 | 69.0 | 4.71 | 2.31 | 1.01 | 140.1 |
| | 5 | 1.39 | 1.36 | 0.24 | 7.8 | 2.82 | 1.84 | 0.49 | 32.1 | 2.73 | 1.95 | 0.47 | 30.2 | 3.17 | 1.74 | 0.54 | 40.5 | 4.59 | 2.23 | 0.79 | 84.9 |
| | 6 | 1.25 | 1.25 | 0.18 | 4.4 | 2.64 | 1.79 | 0.38 | 19.5 | 2.58 | 1.89 | 0.37 | 18.7 | 3.01 | 1.65 | 0.43 | 25.4 | 4.41 | 2.19 | 0.63 | 54.6 |
| | 7 | 1.09 | 1.09 | 0.13 | 2.4 | 2.48 | 1.71 | 0.30 | 12.7 | 2.40 | 1.82 | 0.30 | 11.9 | 2.82 | 1.59 | 0.35 | 16.3 | 4.26 | 2.10 | 0.52 | 37.4 |
| 9 | 3 | 1.49 | 1.41 | 0.43 | 24.8 | 2.89 | 1.90 | 0.83 | 93.5 | 2.81 | 2.00 | 0.80 | 88.3 | 3.24 | 1.77 | 0.93 | 118.0 | 4.67 | 2.31 | 1.34 | 244.6 |
| | 4 | 1.35 | 1.35 | 0.29 | 11.5 | 2.73 | 1.83 | 0.59 | 46.9 | 2.64 | 1.94 | 0.57 | 44.1 | 3.08 | 1.71 | 0.66 | 59.7 | 4.50 | 2.23 | 0.97 | 127.7 |
| | 5 | 1.25 | 1.21 | 0.21 | 6.3 | 2.58 | 1.76 | 0.44 | 26.9 | 2.50 | 1.87 | 0.43 | 25.2 | 2.93 | 1.63 | 0.50 | 34.6 | 4.37 | 2.14 | 0.75 | 77.1 |
| | 6 | 1.09 | 1.09 | 0.16 | 3.3 | 2.41 | 1.69 | 0.35 | 16.3 | 2.32 | 1.81 | 0.33 | 15.1 | 2.77 | 1.56 | 0.40 | 21.5 | 4.19 | 2.10 | 0.60 | 49.1 |
| | 7 | 0.89 | 0.89 | 0.11 | 1.6 | 2.23 | 1.61 | 0.27 | 10.2 | 2.15 | 1.73 | 0.26 | 9.5 | 2.58 | 1.49 | 0.32 | 13.7 | 4.05 | 2.02 | 0.50 | 33.7 |
| 10 | 3 | 1.31 | 1.31 | 0.38 | 19.3 | 2.65 | 1.80 | 0.76 | 78.6 | 2.54 | 1.92 | 0.73 | 72.4 | 3.02 | 1.68 | 0.86 | 102.1 | 4.46 | 2.19 | 1.28 | 222.7 |
| | 4 | 1.20 | 1.20 | 0.26 | 9.1 | 2.49 | 1.74 | 0.53 | 39.0 | 2.40 | 1.86 | 0.52 | 36.3 | 2.84 | 1.62 | 0.61 | 50.9 | 4.27 | 2.14 | 0.92 | 115.1 |
| | 5 | 1.08 | 1.08 | 0.19 | 4.7 | 2.32 | 1.68 | 0.40 | 21.8 | 2.22 | 1.80 | 0.38 | 20.0 | 2.69 | 1.54 | 0.46 | 29.2 | 4.14 | 2.07 | 0.71 | 69.2 |
| | 6 | 0.92 | 0.92 | 0.13 | 2.4 | 2.16 | 1.61 | 0.31 | 13.1 | 2.07 | 1.73 | 0.30 | 12.0 | 2.52 | 1.47 | 0.36 | 17.7 | 3.96 | 2.01 | 0.57 | 44.0 |
| | 7 | 0.59 | 0.59 | 0.07 | 0.7 | 1.98 | 1.54 | 0.24 | 8.0 | 1.88 | 1.67 | 0.23 | 7.3 | 2.35 | 1.39 | 0.29 | 11.4 | 3.78 | 1.93 | 0.46 | 29.5 |
| 11 | 3 | 1.16 | 1.16 | 0.33 | 15.0 | 2.39 | 1.72 | 0.69 | 64.1 | 2.31 | 1.83 | 0.66 | 59.6 | 2.77 | 1.59 | 0.79 | 86.2 | 4.20 | 2.10 | 1.21 | 198.2 |
| | 4 | 1.06 | 1.06 | 0.23 | 7.1 | 2.24 | 1.66 | 0.48 | 31.7 | 2.15 | 1.77 | 0.46 | 29.2 | 2.62 | 1.53 | 0.56 | 43.2 | 4.03 | 2.05 | 0.87 | 102.6 |
| | 5 | 0.92 | 0.92 | 0.16 | 3.4 | 2.07 | 1.60 | 0.36 | 17.3 | 1.98 | 1.72 | 0.34 | 15.8 | 2.45 | 1.45 | 0.42 | 24.2 | 3.90 | 1.98 | 0.67 | 61.5 |
| | 6 | 0.73 | 0.73 | 0.10 | 1.5 | 1.89 | 1.53 | 0.27 | 10.0 | 1.81 | 1.65 | 0.26 | 9.2 | 2.27 | 1.38 | 0.33 | 14.5 | 3.72 | 1.92 | 0.53 | 38.9 |
| | 7 | 0.49 | 0.49 | 0.06 | 0.5 | 1.68 | 1.48 | 0.21 | 5.8 | 1.62 | 1.62 | 0.20 | 5.4 | 2.09 | 1.30 | 0.26 | 9.0 | 3.55 | 1.84 | 0.44 | 26.0 |
| 12 | 3 | 1.02 | 1.02 | 0.29 | 11.7 | 2.14 | 1.64 | 0.61 | 51.3 | 2.04 | 1.77 | 0.58 | 46.5 | 2.52 | 1.50 | 0.72 | 71.2 | 3.97 | 2.02 | 1.14 | 176.6 |
| | 4 | 0.90 | 0.90 | 0.19 | 5.1 | 1.98 | 1.59 | 0.43 | 24.7 | 1.88 | 1.71 | 0.40 | 22.3 | 2.37 | 1.44 | 0.51 | 35.4 | 3.80 | 1.96 | 0.82 | 91.1 |
| | 5 | 0.78 | 0.78 | 0.13 | 2.4 | 1.81 | 1.53 | 0.31 | 13.2 | 1.71 | 1.65 | 0.29 | 11.9 | 2.20 | 1.37 | 0.38 | 19.5 | 3.66 | 1.89 | 0.63 | 53.9 |
| | 6 | 0.47 | 0.47 | 0.07 | 0.6 | 1.61 | 1.48 | 0.23 | 7.2 | 1.59 | 1.56 | 0.23 | 7.1 | 2.01 | 1.29 | 0.29 | 11.4 | 3.48 | 1.83 | 0.50 | 33.9 |
| | 7 | 0.39 | 0.39 | 0.05 | 0.3 | 1.42 | 1.42 | 0.17 | 4.2 | 1.47 | 1.47 | 0.18 | 4.4 | 1.83 | 1.22 | 0.22 | 6.9 | 3.31 | 1.76 | 0.41 | 22.5 |
| 13 | 3 | 0.88 | 0.88 | 0.25 | 8.7 | 1.87 | 1.57 | 0.54 | 39.1 | 1.76 | 1.70 | 0.50 | 34.8 | 2.27 | 1.42 | 0.65 | 57.8 | 3.72 | 1.94 | 1.07 | 154.8 |
| | 4 | 0.75 | 0.75 | 0.16 | 3.5 | 1.71 | 1.51 | 0.37 | 18.4 | 1.65 | 1.62 | 0.35 | 17.2 | 2.11 | 1.35 | 0.45 | 28.0 | 3.56 | 1.87 | 0.76 | 79.8 |
| | 5 | 0.54 | 0.54 | 0.09 | 1.2 | 1.53 | 1.49 | 0.26 | 9.4 | 1.54 | 1.54 | 0.27 | 9.6 | 1.94 | 1.29 | 0.33 | 15.2 | 3.40 | 1.80 | 0.58 | 46.6 |
| | 6 | 0.36 | 0.36 | 0.05 | 0.4 | 1.39 | 1.39 | 0.20 | 5.4 | 1.44 | 1.44 | 0.21 | 5.8 | 1.75 | 1.22 | 0.25 | 8.6 | 3.22 | 1.75 | 0.46 | 29.1 |
| | 7 | 0.27 | 0.27 | 0.03 | 0.1 | 1.27 | 1.27 | 0.16 | 3.3 | 1.32 | 1.32 | 0.16 | 3.6 | 1.53 | 1.15 | 0.19 | 4.8 | 3.06 | 1.68 | 0.38 | 19.2 |

Cooling Capacity

| TKG-400-B | | | | | | | | | | | | | | | | | | | | | |
|-----------|----|---------------------|------|------|------|-----------------|------|------|-------|-------------|------|------|-------|-------------|------|------|-------|-------------|------|------|-------|
| EWT | Δt | Air inlet condition | | | | | | | | | | | | | | | | | | | |
| | | DB:21 WB:15 | | | | DB:26.7 WB:19.4 | | | | DB:27 WB:19 | | | | DB:29 WB:21 | | | | DB:33 WB:25 | | | |
| | | TC | SC | WF | WPD | TC | SC | WF | WPD | TC | SC | WF | WPD | TC | SC | WF | WPD | TC | SC | WF | WPD |
| 5 | 3 | 2.71 | 1.97 | 0.78 | 82.6 | 4.18 | 2.52 | 1.20 | 196.2 | 4.09 | 2.63 | 1.17 | 188.3 | 4.57 | 2.40 | 1.31 | 234.8 | 6.15 | 2.98 | 1.76 | 425.2 |
| | 4 | 2.55 | 1.86 | 0.55 | 41.1 | 4.02 | 2.44 | 0.86 | 102.0 | 3.95 | 2.55 | 0.85 | 98.7 | 4.39 | 2.32 | 0.94 | 121.9 | 5.96 | 2.89 | 1.28 | 224.7 |
| | 5 | 2.36 | 1.78 | 0.41 | 22.5 | 3.84 | 2.36 | 0.66 | 59.7 | 3.77 | 2.47 | 0.65 | 57.4 | 4.22 | 3.65 | 0.73 | 72.1 | 5.77 | 2.84 | 0.99 | 134.8 |
| | 6 | 2.15 | 1.70 | 0.31 | 13.0 | 3.67 | 2.29 | 0.53 | 37.9 | 3.60 | 2.39 | 0.52 | 36.4 | 4.04 | 2.15 | 0.58 | 45.8 | 5.63 | 2.75 | 0.81 | 89.1 |
| | 7 | 1.93 | 1.60 | 0.24 | 7.7 | 3.49 | 2.18 | 0.43 | 25.2 | 3.41 | 2.30 | 0.42 | 24.0 | 3.87 | 2.06 | 0.48 | 30.8 | 5.44 | 2.65 | 0.67 | 61.1 |
| 6 | 3 | 2.45 | 1.86 | 0.70 | 67.5 | 3.94 | 2.42 | 1.13 | 174.6 | 3.85 | 2.52 | 1.10 | 166.7 | 4.34 | 2.29 | 1.24 | 211.6 | 5.92 | 2.89 | 1.70 | 393.1 |
| | 4 | 2.28 | 1.77 | 0.49 | 32.7 | 3.79 | 2.33 | 0.81 | 90.6 | 3.70 | 2.44 | 0.79 | 86.3 | 4.17 | 2.22 | 0.90 | 109.6 | 5.73 | 2.79 | 1.23 | 207.2 |
| | 5 | 2.10 | 1.68 | 0.36 | 17.9 | 3.60 | 2.25 | 0.62 | 52.5 | 3.53 | 2.37 | 0.61 | 50.4 | 4.00 | 2.13 | 0.69 | 64.7 | 5.54 | 2.70 | 0.95 | 124.0 |
| | 6 | 1.89 | 1.61 | 0.27 | 10.0 | 3.43 | 2.18 | 0.49 | 33.1 | 3.35 | 2.28 | 0.48 | 31.5 | 3.80 | 2.04 | 0.54 | 40.6 | 5.40 | 2.60 | 0.77 | 81.7 |
| | 7 | 1.66 | 1.50 | 0.20 | 5.7 | 3.25 | 2.08 | 0.40 | 21.8 | 3.17 | 2.22 | 0.39 | 20.7 | 3.63 | 1.95 | 0.45 | 27.2 | 5.21 | 2.56 | 0.64 | 55.9 |
| 7 | 3 | 2.19 | 1.74 | 0.63 | 53.9 | 3.68 | 2.30 | 1.06 | 152.3 | 3.60 | 2.42 | 1.03 | 145.7 | 4.08 | 2.18 | 1.17 | 187.4 | 5.63 | 2.75 | 1.61 | 356.3 |
| | 4 | 2.01 | 1.68 | 0.43 | 25.6 | 3.53 | 2.22 | 0.76 | 78.8 | 3.44 | 2.34 | 0.74 | 74.6 | 3.92 | 2.11 | 0.84 | 97.3 | 5.49 | 2.70 | 1.18 | 190.4 |
| | 5 | 1.82 | 1.60 | 0.31 | 13.4 | 3.35 | 2.14 | 0.58 | 45.4 | 3.28 | 2.26 | 0.56 | 43.5 | 3.73 | 2.02 | 0.64 | 56.4 | 5.30 | 2.60 | 0.91 | 113.6 |
| | 6 | 1.60 | 1.51 | 0.23 | 7.2 | 3.18 | 2.08 | 0.46 | 28.3 | 3.12 | 2.18 | 0.45 | 27.3 | 3.56 | 1.93 | 0.51 | 35.7 | 5.16 | 2.51 | 0.74 | 74.7 |
| | 7 | 1.39 | 1.39 | 0.17 | 4.0 | 3.01 | 1.98 | 0.37 | 18.6 | 2.91 | 2.11 | 0.36 | 17.4 | 3.37 | 1.85 | 0.41 | 23.5 | 4.97 | 2.41 | 0.61 | 51.0 |
| 8 | 3 | 1.92 | 1.65 | 0.55 | 41.5 | 3.43 | 2.20 | 0.98 | 132.3 | 3.35 | 2.30 | 0.96 | 126.1 | 3.84 | 2.06 | 1.10 | 165.5 | 5.40 | 2.65 | 1.55 | 327.0 |
| | 4 | 1.73 | 1.60 | 0.37 | 19.0 | 3.28 | 2.13 | 0.71 | 68.0 | 3.18 | 2.25 | 0.68 | 63.9 | 3.65 | 2.00 | 0.79 | 84.3 | 5.21 | 2.56 | 1.12 | 171.2 |
| | 5 | 1.53 | 1.50 | 0.26 | 9.5 | 3.11 | 2.04 | 0.54 | 39.2 | 3.02 | 2.16 | 0.52 | 36.9 | 3.50 | 1.92 | 0.60 | 49.5 | 5.06 | 2.46 | 0.87 | 103.7 |
| | 6 | 1.38 | 1.38 | 0.20 | 5.3 | 2.91 | 1.97 | 0.42 | 23.8 | 2.85 | 2.08 | 0.41 | 22.9 | 3.32 | 1.83 | 0.48 | 31.0 | 4.88 | 2.41 | 0.70 | 66.7 |
| | 7 | 1.20 | 1.20 | 0.15 | 3.0 | 2.74 | 1.88 | 0.34 | 15.5 | 2.66 | 2.01 | 0.33 | 14.5 | 3.11 | 1.75 | 0.38 | 19.9 | 4.70 | 2.32 | 0.58 | 45.7 |
| 9 | 3 | 1.64 | 1.56 | 0.47 | 30.3 | 3.19 | 2.10 | 0.91 | 114.3 | 3.10 | 2.21 | 0.89 | 107.9 | 3.58 | 1.96 | 1.03 | 144.2 | 5.16 | 2.56 | 1.48 | 298.9 |
| | 4 | 1.49 | 1.49 | 0.32 | 14.0 | 3.01 | 2.03 | 0.65 | 57.2 | 2.92 | 2.14 | 0.63 | 53.9 | 3.40 | 1.89 | 0.73 | 73.0 | 4.97 | 2.46 | 1.07 | 156.0 |
| | 5 | 1.38 | 1.33 | 0.24 | 7.7 | 2.85 | 1.94 | 0.49 | 32.8 | 2.76 | 2.07 | 0.47 | 30.8 | 3.23 | 1.80 | 0.56 | 42.3 | 4.83 | 2.37 | 0.83 | 94.2 |
| | 6 | 1.21 | 1.21 | 0.17 | 4.1 | 2.66 | 1.87 | 0.38 | 19.9 | 2.57 | 2.00 | 0.37 | 18.5 | 3.06 | 1.72 | 0.44 | 26.3 | 4.62 | 2.31 | 0.66 | 60.0 |
| | 7 | 0.98 | 0.98 | 0.12 | 2.0 | 2.46 | 1.78 | 0.30 | 12.5 | 2.38 | 1.91 | 0.29 | 11.6 | 2.85 | 1.64 | 0.35 | 16.7 | 4.47 | 2.23 | 0.55 | 41.2 |
| 10 | 3 | 1.45 | 1.45 | 0.42 | 23.6 | 2.93 | 1.99 | 0.84 | 96.1 | 2.81 | 2.13 | 0.80 | 88.5 | 3.33 | 1.86 | 0.96 | 124.7 | 4.92 | 2.41 | 1.41 | 272.1 |
| | 4 | 1.33 | 1.33 | 0.29 | 11.2 | 2.75 | 1.92 | 0.59 | 47.6 | 2.65 | 2.05 | 0.57 | 44.4 | 3.14 | 1.78 | 0.67 | 62.2 | 4.72 | 2.37 | 1.01 | 140.7 |
| | 5 | 1.19 | 1.19 | 0.20 | 5.7 | 2.57 | 1.86 | 0.44 | 26.6 | 2.46 | 1.99 | 0.42 | 24.4 | 2.97 | 1.70 | 0.51 | 35.7 | 4.57 | 2.28 | 0.79 | 84.5 |
| | 6 | 1.02 | 1.02 | 0.15 | 2.9 | 2.39 | 1.77 | 0.34 | 16.0 | 2.28 | 1.91 | 0.33 | 14.6 | 2.78 | 1.62 | 0.40 | 21.7 | 4.37 | 2.22 | 0.63 | 53.7 |
| | 7 | 0.65 | 0.65 | 0.08 | 0.9 | 2.18 | 1.70 | 0.27 | 9.8 | 2.08 | 1.84 | 0.26 | 8.9 | 2.60 | 1.54 | 0.32 | 13.9 | 4.18 | 2.13 | 0.51 | 36.0 |
| 11 | 3 | 1.28 | 1.28 | 0.37 | 18.3 | 2.64 | 1.90 | 0.76 | 78.3 | 2.55 | 2.03 | 0.73 | 72.8 | 3.06 | 1.76 | 0.88 | 105.3 | 4.64 | 2.32 | 1.33 | 242.1 |
| | 4 | 1.17 | 1.17 | 0.25 | 8.6 | 2.48 | 1.84 | 0.53 | 38.7 | 2.38 | 1.95 | 0.51 | 35.7 | 2.89 | 1.68 | 0.62 | 52.8 | 4.45 | 2.26 | 0.96 | 125.3 |
| | 5 | 1.01 | 1.01 | 0.17 | 4.1 | 2.29 | 1.77 | 0.39 | 21.1 | 2.18 | 1.90 | 0.38 | 19.2 | 2.70 | 1.60 | 0.46 | 29.5 | 4.31 | 2.18 | 0.74 | 75.2 |
| | 6 | 0.80 | 0.80 | 0.12 | 1.8 | 2.08 | 1.69 | 0.30 | 12.2 | 2.00 | 1.82 | 0.29 | 11.3 | 2.51 | 1.52 | 0.36 | 17.7 | 4.11 | 2.13 | 0.59 | 47.5 |
| | 7 | 0.54 | 0.54 | 0.07 | 0.6 | 1.86 | 1.63 | 0.23 | 7.1 | 1.79 | 1.79 | 0.22 | 6.6 | 2.31 | 1.43 | 0.28 | 11.0 | 3.92 | 2.04 | 0.48 | 31.8 |
| 12 | 3 | 1.13 | 1.13 | 0.32 | 14.3 | 2.36 | 1.81 | 0.68 | 62.7 | 2.25 | 1.95 | 0.64 | 56.8 | 2.78 | 1.66 | 0.80 | 87.0 | 4.38 | 2.23 | 1.26 | 215.7 |
| | 4 | 0.99 | 0.99 | 0.21 | 6.2 | 2.19 | 1.75 | 0.47 | 30.2 | 2.08 | 1.89 | 0.45 | 27.3 | 2.62 | 1.59 | 0.56 | 43.3 | 4.20 | 2.16 | 0.90 | 111.3 |
| | 5 | 0.86 | 0.86 | 0.15 | 3.0 | 2.00 | 1.69 | 0.34 | 16.1 | 1.89 | 1.83 | 0.33 | 14.5 | 2.43 | 1.51 | 0.42 | 23.8 | 4.04 | 2.08 | 0.69 | 65.9 |
| | 6 | 0.52 | 0.52 | 0.07 | 0.7 | 1.77 | 1.63 | 0.25 | 8.8 | 1.76 | 1.72 | 0.25 | 8.7 | 2.22 | 1.43 | 0.32 | 13.9 | 3.84 | 2.03 | 0.55 | 41.5 |
| | 7 | 0.43 | 0.43 | 0.05 | 0.4 | 1.57 | 1.57 | 0.19 | 5.1 | 1.62 | 1.62 | 0.20 | 5.4 | 2.02 | 1.34 | 0.25 | 8.4 | 3.65 | 1.95 | 0.45 | 27.5 |
| 13 | 3 | 0.97 | 0.97 | 0.28 | 10.6 | 2.06 | 1.73 | 0.59 | 47.8 | 1.95 | 1.88 | 0.56 | 42.5 | 2.51 | 1.57 | 0.72 | 70.7 | 4.10 | 2.14 | 1.18 | 189.1 |
| | 4 | 0.83 | 0.83 | 0.18 | 4.3 | 1.89 | 1.67 | 0.41 | 22.5 | 1.82 | 1.79 | 0.39 | 21.0 | 2.33 | 1.49 | 0.50 | 34.3 | 3.93 | 2.06 | 0.84 | 97.5 |
| | 5 | 0.60 | 0.60 | 0.10 | 1.4 | 1.68 | 1.65 | 0.29 | 11.5 | 1.70 | 1.70 | 0.29 | 11.7 | 2.14 | 1.42 | 0.37 | 18.6 | 3.75 | 1.98 | 0.65 | 57.0 |
| | 6 | 0.40 | 0.40 | 0.06 | 0.4 | 1.53 | 1.53 | 0.22 | 6.6 | 1.59 | 1.59 | 0.23 | 7.1 | 1.94 | 1.34 | 0.28 | 10.5 | 3.56 | 1.93 | 0.51 | 35.6 |
| | 7 | 0.29 | 0.29 | 0.04 | 0.2 | 1.40 | 1.40 | 0.17 | 4.0 | 1.46 | 1.46 | 0.18 | 4.4 | 1.69 | 1.27 | 0.21 | 5.9 | 3.37 | 1.85 | 0.41 | 23.5 |

Cooling Capacity

| TKG-500-B | | | | | | | | | | | | | | | | | | | | | |
|-----------|----|---------------------|------|------|------|-----------------|------|------|-------|-------------|------|------|-------|-------------|------|------|-------|-------------|------|------|-------|
| EWT | Δt | Air inlet condition | | | | | | | | | | | | | | | | | | | |
| | | DB:21 WB:15 | | | | DB:26.7 WB:19.4 | | | | DB:27 WB:19 | | | | DB:29 WB:21 | | | | DB:33 WB:25 | | | |
| | | TC | SC | WF | WPD | TC | SC | WF | WPD | TC | SC | WF | WPD | TC | SC | WF | WPD | TC | SC | WF | WPD |
| 5 | 3 | 3.51 | 2.55 | 1.01 | 60.4 | 5.42 | 3.26 | 1.55 | 143.4 | 5.30 | 3.40 | 1.52 | 137.6 | 5.92 | 3.11 | 1.70 | 171.6 | 7.97 | 3.86 | 2.29 | 310.8 |
| | 4 | 3.31 | 2.41 | 0.71 | 30.1 | 5.21 | 3.16 | 1.12 | 74.6 | 5.12 | 3.31 | 1.10 | 72.1 | 5.69 | 3.01 | 1.22 | 89.1 | 7.73 | 3.74 | 1.66 | 164.3 |
| | 5 | 3.05 | 2.31 | 0.53 | 16.4 | 4.98 | 3.05 | 0.86 | 43.7 | 4.88 | 3.20 | 0.84 | 42.0 | 5.47 | 4.73 | 0.94 | 52.7 | 7.48 | 3.68 | 1.29 | 98.6 |
| | 6 | 2.79 | 2.21 | 0.40 | 9.5 | 4.76 | 2.97 | 0.68 | 27.7 | 4.67 | 3.09 | 0.67 | 26.6 | 5.23 | 2.78 | 0.75 | 33.5 | 7.30 | 3.56 | 1.05 | 65.1 |
| | 7 | 2.50 | 2.07 | 0.31 | 5.6 | 4.53 | 2.83 | 0.56 | 18.4 | 4.42 | 2.99 | 0.54 | 17.6 | 5.01 | 2.67 | 0.62 | 22.6 | 7.05 | 3.43 | 0.87 | 44.7 |
| 6 | 3 | 3.18 | 2.40 | 0.91 | 49.4 | 5.11 | 3.13 | 1.46 | 127.6 | 4.99 | 3.27 | 1.43 | 121.9 | 5.62 | 2.97 | 1.61 | 154.7 | 7.67 | 3.74 | 2.20 | 287.4 |
| | 4 | 2.95 | 2.29 | 0.63 | 23.9 | 4.91 | 3.02 | 1.05 | 66.2 | 4.79 | 3.16 | 1.03 | 63.1 | 5.40 | 2.87 | 1.16 | 80.1 | 7.42 | 3.62 | 1.60 | 151.5 |
| | 5 | 2.72 | 2.18 | 0.47 | 13.1 | 4.67 | 2.91 | 0.80 | 38.3 | 4.58 | 3.07 | 0.79 | 36.9 | 5.18 | 2.76 | 0.89 | 47.3 | 7.18 | 3.50 | 1.23 | 90.6 |
| | 6 | 2.45 | 2.09 | 0.35 | 7.3 | 4.45 | 2.83 | 0.64 | 24.2 | 4.34 | 2.95 | 0.62 | 23.0 | 4.92 | 2.64 | 0.71 | 29.7 | 6.99 | 3.37 | 1.00 | 59.8 |
| | 7 | 2.15 | 1.94 | 0.26 | 4.2 | 4.21 | 2.70 | 0.52 | 15.9 | 4.11 | 2.87 | 0.50 | 15.2 | 4.70 | 2.53 | 0.58 | 19.9 | 6.75 | 3.31 | 0.83 | 40.9 |
| 7 | 3 | 2.84 | 2.26 | 0.81 | 39.4 | 4.77 | 2.98 | 1.37 | 111.3 | 4.67 | 3.13 | 1.34 | 106.5 | 5.29 | 2.82 | 1.52 | 137.0 | 7.30 | 3.56 | 2.09 | 260.5 |
| | 4 | 2.61 | 2.17 | 0.56 | 18.7 | 4.58 | 2.88 | 0.98 | 57.6 | 4.45 | 3.03 | 0.96 | 54.5 | 5.08 | 2.73 | 1.09 | 71.1 | 7.11 | 3.50 | 1.53 | 139.2 |
| | 5 | 2.35 | 2.07 | 0.41 | 9.8 | 4.34 | 2.77 | 0.75 | 33.2 | 4.25 | 2.93 | 0.73 | 31.8 | 4.84 | 2.62 | 0.83 | 41.2 | 6.87 | 3.37 | 1.18 | 83.1 |
| | 6 | 2.07 | 1.96 | 0.30 | 5.3 | 4.12 | 2.69 | 0.59 | 20.7 | 4.04 | 2.82 | 0.58 | 20.0 | 4.62 | 2.50 | 0.66 | 26.1 | 6.68 | 3.25 | 0.96 | 54.6 |
| | 7 | 1.80 | 1.80 | 0.22 | 2.9 | 3.89 | 2.57 | 0.48 | 13.6 | 3.77 | 2.74 | 0.46 | 12.7 | 4.37 | 2.40 | 0.54 | 17.2 | 6.44 | 3.13 | 0.79 | 37.2 |
| 8 | 3 | 2.49 | 2.14 | 0.71 | 30.3 | 4.45 | 2.85 | 1.27 | 96.7 | 4.34 | 2.99 | 1.24 | 92.2 | 4.97 | 2.67 | 1.43 | 121.0 | 6.99 | 3.43 | 2.00 | 239.0 |
| | 4 | 2.24 | 2.07 | 0.48 | 13.9 | 4.25 | 2.75 | 0.91 | 49.7 | 4.12 | 2.92 | 0.89 | 46.7 | 4.73 | 2.59 | 1.02 | 61.7 | 6.75 | 3.31 | 1.45 | 125.2 |
| | 5 | 1.99 | 1.94 | 0.34 | 7.0 | 4.04 | 2.64 | 0.69 | 28.7 | 3.91 | 2.80 | 0.67 | 27.0 | 4.53 | 2.48 | 0.78 | 36.2 | 6.56 | 3.19 | 1.13 | 75.8 |
| | 6 | 1.78 | 1.78 | 0.26 | 3.9 | 3.77 | 2.56 | 0.54 | 17.4 | 3.70 | 2.70 | 0.53 | 16.7 | 4.31 | 2.37 | 0.62 | 22.7 | 6.32 | 3.13 | 0.91 | 48.8 |
| | 7 | 1.56 | 1.56 | 0.19 | 2.2 | 3.55 | 2.44 | 0.44 | 11.3 | 3.44 | 2.61 | 0.42 | 10.6 | 4.03 | 2.27 | 0.50 | 14.6 | 6.10 | 3.01 | 0.75 | 33.4 |
| 9 | 3 | 2.13 | 2.02 | 0.61 | 22.1 | 4.13 | 2.72 | 1.18 | 83.6 | 4.02 | 2.86 | 1.15 | 78.9 | 4.64 | 2.54 | 1.33 | 105.4 | 6.68 | 3.31 | 1.92 | 218.5 |
| | 4 | 1.93 | 1.93 | 0.42 | 10.3 | 3.90 | 2.62 | 0.84 | 41.8 | 3.78 | 2.77 | 0.81 | 39.4 | 4.40 | 2.45 | 0.95 | 53.3 | 6.44 | 3.19 | 1.38 | 114.1 |
| | 5 | 1.78 | 1.73 | 0.31 | 5.6 | 3.69 | 2.51 | 0.64 | 24.0 | 3.58 | 2.68 | 0.61 | 22.5 | 4.19 | 2.34 | 0.72 | 30.9 | 6.26 | 3.07 | 1.08 | 68.9 |
| | 6 | 1.56 | 1.56 | 0.22 | 3.0 | 3.45 | 2.42 | 0.49 | 14.5 | 3.32 | 2.59 | 0.48 | 13.5 | 3.97 | 2.23 | 0.57 | 19.2 | 5.99 | 3.00 | 0.86 | 43.9 |
| | 7 | 1.28 | 1.28 | 0.16 | 1.5 | 3.19 | 2.31 | 0.39 | 9.1 | 3.08 | 2.48 | 0.38 | 8.5 | 3.69 | 2.13 | 0.45 | 12.2 | 5.79 | 2.89 | 0.71 | 30.1 |
| 10 | 3 | 1.88 | 1.88 | 0.54 | 17.2 | 3.79 | 2.58 | 1.09 | 70.2 | 3.64 | 2.75 | 1.04 | 64.7 | 4.32 | 2.40 | 1.24 | 91.2 | 6.38 | 3.13 | 1.83 | 198.9 |
| | 4 | 1.72 | 1.72 | 0.37 | 8.2 | 3.56 | 2.48 | 0.76 | 34.8 | 3.43 | 2.66 | 0.74 | 32.4 | 4.07 | 2.31 | 0.87 | 45.5 | 6.11 | 3.07 | 1.31 | 102.8 |
| | 5 | 1.54 | 1.54 | 0.26 | 4.2 | 3.32 | 2.40 | 0.57 | 19.5 | 3.18 | 2.58 | 0.55 | 17.8 | 3.85 | 2.21 | 0.66 | 26.1 | 5.92 | 2.96 | 1.02 | 61.8 |
| | 6 | 1.32 | 1.32 | 0.19 | 2.1 | 3.10 | 2.30 | 0.44 | 11.7 | 2.96 | 2.48 | 0.42 | 10.7 | 3.60 | 2.10 | 0.52 | 15.8 | 5.67 | 2.88 | 0.81 | 39.3 |
| | 7 | 0.84 | 0.84 | 0.10 | 0.6 | 2.83 | 2.20 | 0.35 | 7.2 | 2.69 | 2.39 | 0.33 | 6.5 | 3.37 | 1.99 | 0.41 | 10.2 | 5.42 | 2.76 | 0.67 | 26.3 |
| 11 | 3 | 1.66 | 1.66 | 0.47 | 13.4 | 3.42 | 2.47 | 0.98 | 57.3 | 3.30 | 2.62 | 0.95 | 53.2 | 3.97 | 2.28 | 1.14 | 77.0 | 6.02 | 3.01 | 1.72 | 177.0 |
| | 4 | 1.51 | 1.51 | 0.33 | 6.3 | 3.21 | 2.38 | 0.69 | 28.3 | 3.08 | 2.53 | 0.66 | 26.1 | 3.75 | 2.18 | 0.81 | 38.6 | 5.77 | 2.93 | 1.24 | 91.6 |
| | 5 | 1.31 | 1.31 | 0.23 | 3.0 | 2.96 | 2.29 | 0.51 | 15.4 | 2.83 | 2.47 | 0.49 | 14.1 | 3.50 | 2.08 | 0.60 | 21.6 | 5.59 | 2.83 | 0.96 | 55.0 |
| | 6 | 1.04 | 1.04 | 0.15 | 1.3 | 2.70 | 2.20 | 0.39 | 8.9 | 2.59 | 2.35 | 0.37 | 8.2 | 3.25 | 1.97 | 0.47 | 12.9 | 5.33 | 2.75 | 0.76 | 34.7 |
| | 7 | 0.71 | 0.71 | 0.09 | 0.4 | 2.40 | 2.12 | 0.30 | 5.2 | 2.32 | 2.32 | 0.28 | 4.8 | 2.99 | 1.86 | 0.37 | 8.0 | 5.08 | 2.64 | 0.62 | 23.2 |
| 12 | 3 | 1.46 | 1.46 | 0.42 | 10.4 | 3.06 | 2.35 | 0.88 | 45.8 | 2.91 | 2.53 | 0.84 | 41.5 | 3.61 | 2.15 | 1.03 | 63.6 | 5.68 | 2.89 | 1.63 | 157.7 |
| | 4 | 1.29 | 1.29 | 0.28 | 4.6 | 2.83 | 2.27 | 0.61 | 22.1 | 2.69 | 2.45 | 0.58 | 19.9 | 3.39 | 2.05 | 0.73 | 31.6 | 5.44 | 2.80 | 1.17 | 81.4 |
| | 5 | 1.11 | 1.11 | 0.19 | 2.2 | 2.59 | 2.19 | 0.45 | 11.8 | 2.45 | 2.37 | 0.42 | 10.6 | 3.15 | 1.96 | 0.54 | 17.4 | 5.23 | 2.70 | 0.90 | 48.2 |
| | 6 | 0.67 | 0.67 | 0.10 | 0.5 | 2.30 | 2.12 | 0.33 | 6.5 | 2.28 | 2.23 | 0.33 | 6.3 | 2.88 | 1.85 | 0.41 | 10.2 | 4.98 | 2.62 | 0.71 | 30.3 |
| | 7 | 0.55 | 0.55 | 0.07 | 0.3 | 2.04 | 2.04 | 0.25 | 3.7 | 2.10 | 2.10 | 0.26 | 4.0 | 2.62 | 1.74 | 0.32 | 6.2 | 4.73 | 2.52 | 0.58 | 20.1 |
| 13 | 3 | 1.26 | 1.26 | 0.36 | 7.7 | 2.67 | 2.24 | 0.77 | 35.0 | 2.52 | 2.43 | 0.72 | 31.1 | 3.25 | 2.03 | 0.93 | 51.7 | 5.32 | 2.78 | 1.52 | 138.3 |
| | 4 | 1.07 | 1.07 | 0.23 | 3.2 | 2.45 | 2.16 | 0.53 | 16.5 | 2.36 | 2.32 | 0.51 | 15.3 | 3.02 | 1.93 | 0.65 | 25.0 | 5.09 | 2.67 | 1.09 | 71.3 |
| | 5 | 0.77 | 0.77 | 0.13 | 1.1 | 2.18 | 2.13 | 0.38 | 8.4 | 2.21 | 2.21 | 0.38 | 8.6 | 2.78 | 1.84 | 0.48 | 13.6 | 4.86 | 2.57 | 0.84 | 41.6 |
| | 6 | 0.52 | 0.52 | 0.07 | 0.3 | 1.99 | 1.99 | 0.28 | 4.8 | 2.05 | 2.05 | 0.29 | 5.2 | 2.51 | 1.74 | 0.36 | 7.7 | 4.61 | 2.50 | 0.66 | 26.0 |
| | 7 | 0.38 | 0.38 | 0.05 | 0.1 | 1.82 | 1.82 | 0.22 | 3.0 | 1.89 | 1.89 | 0.23 | 3.2 | 2.20 | 1.64 | 0.27 | 4.3 | 4.37 | 2.40 | 0.54 | 17.2 |

Cooling Capacity

| TKG-600-B | | | | | | | | | | | | | | | | | | | | | |
|-----------|----|---------------------|------|------|------|-------------|------|------|-------|-------------|------|------|-------|-------------|------|------|-------|-------------|------|------|-------|
| EWT | Δt | Air inlet condition | | | | | | | | | | | | | | | | | | | |
| | | DB:26.7 WB:19.4 | | | | DB:27 WB:18 | | | | DB:27 WB:19 | | | | DB:27 WB:20 | | | | DB:29 WB:21 | | | |
| | | TC | SC | WF | WPD | TC | SC | WF | WPD | TC | SC | WF | WPD | TC | SC | WF | WPD | TC | SC | WF | WPD |
| 5 | 3 | 4.13 | 3.00 | 1.19 | 80.7 | 6.37 | 3.84 | 1.83 | 191.7 | 6.24 | 4.00 | 1.79 | 183.9 | 6.97 | 3.66 | 2.00 | 229.4 | 9.38 | 4.55 | 2.69 | 415.4 |
| | 4 | 3.89 | 2.84 | 0.84 | 40.2 | 6.13 | 3.72 | 1.32 | 99.7 | 6.02 | 3.89 | 1.30 | 96.4 | 6.70 | 3.54 | 1.44 | 119.1 | 9.09 | 4.40 | 1.95 | 219.5 |
| | 5 | 3.59 | 2.71 | 0.62 | 21.9 | 5.86 | 3.59 | 1.01 | 58.3 | 5.74 | 3.77 | 0.99 | 56.1 | 6.44 | 5.56 | 1.11 | 70.4 | 8.80 | 4.33 | 1.51 | 131.7 |
| | 6 | 3.28 | 2.60 | 0.47 | 12.7 | 5.60 | 3.49 | 0.80 | 37.0 | 5.49 | 3.64 | 0.79 | 35.6 | 6.15 | 3.28 | 0.88 | 44.7 | 8.59 | 4.18 | 1.23 | 87.0 |
| | 7 | 2.94 | 2.43 | 0.36 | 7.5 | 5.32 | 3.33 | 0.65 | 24.6 | 5.20 | 3.51 | 0.64 | 23.5 | 5.89 | 3.15 | 0.72 | 30.1 | 8.30 | 4.04 | 1.02 | 59.7 |
| 6 | 3 | 3.74 | 2.83 | 1.07 | 66.0 | 6.01 | 3.69 | 1.72 | 170.6 | 5.87 | 3.85 | 1.68 | 162.9 | 6.62 | 3.49 | 1.90 | 206.7 | 9.02 | 4.40 | 2.59 | 384.1 |
| | 4 | 3.47 | 2.69 | 0.75 | 32.0 | 5.77 | 3.56 | 1.24 | 88.5 | 5.63 | 3.72 | 1.21 | 84.3 | 6.35 | 3.38 | 1.37 | 107.1 | 8.73 | 4.26 | 1.88 | 202.4 |
| | 5 | 3.20 | 2.57 | 0.55 | 17.4 | 5.49 | 3.43 | 0.94 | 51.2 | 5.38 | 3.61 | 0.93 | 49.2 | 6.10 | 3.25 | 1.05 | 63.2 | 8.44 | 4.11 | 1.45 | 121.1 |
| | 6 | 2.88 | 2.45 | 0.41 | 9.8 | 5.23 | 3.33 | 0.75 | 32.3 | 5.11 | 3.47 | 0.73 | 30.8 | 5.79 | 3.10 | 0.83 | 39.6 | 8.23 | 3.97 | 1.18 | 79.9 |
| | 7 | 2.53 | 2.28 | 0.31 | 5.6 | 4.96 | 3.17 | 0.61 | 21.3 | 4.83 | 3.38 | 0.59 | 20.3 | 5.53 | 2.97 | 0.68 | 26.6 | 7.94 | 3.90 | 0.98 | 54.6 |
| 7 | 3 | 3.34 | 2.66 | 0.96 | 52.7 | 5.61 | 3.51 | 1.61 | 148.8 | 5.49 | 3.69 | 1.57 | 142.4 | 6.23 | 3.32 | 1.78 | 183.1 | 8.59 | 4.18 | 2.46 | 348.1 |
| | 4 | 3.07 | 2.55 | 0.66 | 25.0 | 5.38 | 3.38 | 1.16 | 77.0 | 5.24 | 3.56 | 1.13 | 72.9 | 5.98 | 3.21 | 1.29 | 95.0 | 8.37 | 4.11 | 1.80 | 186.1 |
| | 5 | 2.77 | 2.43 | 0.48 | 13.0 | 5.11 | 3.26 | 0.88 | 44.4 | 5 | 3.44 | 0.86 | 42.5 | 5.69 | 3.08 | 0.98 | 55.1 | 8.08 | 3.97 | 1.39 | 111.0 |
| | 6 | 2.44 | 2.31 | 0.35 | 7.0 | 4.84 | 3.17 | 0.69 | 27.7 | 4.75 | 3.32 | 0.68 | 26.7 | 5.43 | 2.94 | 0.78 | 34.8 | 7.86 | 3.82 | 1.13 | 73.0 |
| | 7 | 2.11 | 2.11 | 0.26 | 3.9 | 4.58 | 3.02 | 0.56 | 18.2 | 4.43 | 3.22 | 0.54 | 17.0 | 5.14 | 2.82 | 0.63 | 23.0 | 7.58 | 3.68 | 0.93 | 49.8 |
| 8 | 3 | 2.93 | 2.52 | 0.84 | 40.5 | 5.23 | 3.35 | 1.50 | 129.2 | 5.11 | 3.51 | 1.46 | 123.2 | 5.85 | 3.14 | 1.68 | 161.7 | 8.23 | 4.04 | 2.36 | 319.5 |
| | 4 | 2.64 | 2.44 | 0.57 | 18.5 | 5.00 | 3.24 | 1.08 | 66.4 | 4.85 | 3.43 | 1.04 | 62.4 | 5.57 | 3.04 | 1.20 | 82.4 | 7.94 | 3.90 | 1.71 | 167.3 |
| | 5 | 2.34 | 2.29 | 0.40 | 9.3 | 4.75 | 3.10 | 0.82 | 38.3 | 4.60 | 3.29 | 0.79 | 36.0 | 5.33 | 2.92 | 0.92 | 48.3 | 7.72 | 3.75 | 1.33 | 101.3 |
| | 6 | 2.10 | 2.10 | 0.30 | 5.2 | 4.44 | 3.01 | 0.64 | 23.2 | 4.35 | 3.17 | 0.62 | 22.3 | 5.06 | 2.78 | 0.73 | 30.3 | 7.43 | 3.68 | 1.07 | 65.2 |
| | 7 | 1.83 | 1.83 | 0.23 | 2.9 | 4.18 | 2.87 | 0.51 | 15.1 | 4.05 | 3.07 | 0.50 | 14.2 | 4.74 | 2.67 | 0.58 | 19.5 | 7.17 | 3.54 | 0.88 | 44.6 |
| 9 | 3 | 2.50 | 2.37 | 0.72 | 29.6 | 4.86 | 3.20 | 1.39 | 111.7 | 4.73 | 3.36 | 1.35 | 105.5 | 5.46 | 2.99 | 1.57 | 140.9 | 7.86 | 3.90 | 2.25 | 292.1 |
| | 4 | 2.27 | 2.27 | 0.49 | 13.7 | 4.59 | 3.09 | 0.99 | 55.9 | 4.45 | 3.26 | 0.96 | 52.6 | 5.18 | 2.88 | 1.11 | 71.3 | 7.58 | 3.75 | 1.63 | 152.4 |
| | 5 | 2.10 | 2.03 | 0.36 | 7.5 | 4.34 | 2.96 | 0.75 | 32.1 | 4.21 | 3.15 | 0.72 | 30.1 | 4.93 | 2.75 | 0.85 | 41.3 | 7.36 | 3.61 | 1.27 | 92.1 |
| | 6 | 1.84 | 1.84 | 0.26 | 4.0 | 4.05 | 2.85 | 0.58 | 19.4 | 3.91 | 3.05 | 0.56 | 18.1 | 4.67 | 2.62 | 0.67 | 25.7 | 7.05 | 3.53 | 1.01 | 58.7 |
| | 7 | 1.50 | 1.50 | 0.18 | 2.0 | 3.75 | 2.71 | 0.46 | 12.2 | 3.62 | 2.91 | 0.44 | 11.4 | 4.34 | 2.50 | 0.53 | 16.4 | 6.81 | 3.40 | 0.84 | 40.2 |
| 10 | 3 | 2.21 | 2.21 | 0.63 | 23.0 | 4.46 | 3.04 | 1.28 | 93.9 | 4.28 | 3.24 | 1.23 | 86.4 | 5.08 | 2.83 | 1.46 | 121.8 | 7.50 | 3.68 | 2.15 | 265.9 |
| | 4 | 2.03 | 2.03 | 0.44 | 10.9 | 4.18 | 2.92 | 0.90 | 46.5 | 4.04 | 3.13 | 0.87 | 43.4 | 4.78 | 2.72 | 1.03 | 60.8 | 7.19 | 3.61 | 1.55 | 137.4 |
| | 5 | 1.81 | 1.81 | 0.31 | 5.6 | 3.91 | 2.83 | 0.67 | 26.0 | 3.74 | 3.03 | 0.64 | 23.8 | 4.53 | 2.60 | 0.78 | 34.9 | 6.97 | 3.48 | 1.20 | 82.6 |
| | 6 | 1.55 | 1.55 | 0.22 | 2.8 | 3.64 | 2.71 | 0.52 | 15.7 | 3.48 | 2.91 | 0.50 | 14.3 | 4.24 | 2.47 | 0.61 | 21.2 | 6.67 | 3.38 | 0.96 | 52.5 |
| | 7 | 0.99 | 0.99 | 0.12 | 0.8 | 3.33 | 2.59 | 0.41 | 9.6 | 3.17 | 2.81 | 0.39 | 8.7 | 3.96 | 2.34 | 0.49 | 13.6 | 6.37 | 3.25 | 0.78 | 35.2 |
| 11 | 3 | 1.95 | 1.95 | 0.56 | 17.9 | 4.03 | 2.90 | 1.15 | 76.5 | 3.88 | 3.09 | 1.11 | 71.2 | 4.67 | 2.68 | 1.34 | 102.9 | 7.08 | 3.54 | 2.03 | 236.6 |
| | 4 | 1.78 | 1.78 | 0.38 | 8.4 | 3.77 | 2.80 | 0.81 | 37.8 | 3.62 | 2.97 | 0.78 | 34.8 | 4.41 | 2.57 | 0.95 | 51.6 | 6.79 | 3.45 | 1.46 | 122.4 |
| | 5 | 1.54 | 1.54 | 0.27 | 4.1 | 3.48 | 2.69 | 0.60 | 20.6 | 3.33 | 2.90 | 0.57 | 18.8 | 4.12 | 2.45 | 0.71 | 28.9 | 6.57 | 3.33 | 1.13 | 73.4 |
| | 6 | 1.23 | 1.23 | 0.18 | 1.8 | 3.17 | 2.58 | 0.46 | 11.9 | 3.05 | 2.77 | 0.44 | 11.0 | 3.82 | 2.32 | 0.55 | 17.3 | 6.27 | 3.24 | 0.90 | 46.4 |
| | 7 | 0.83 | 0.83 | 0.10 | 0.6 | 2.83 | 2.49 | 0.35 | 6.9 | 2.73 | 2.73 | 0.34 | 6.5 | 3.52 | 2.19 | 0.43 | 10.8 | 5.98 | 3.10 | 0.73 | 31.0 |
| 12 | 3 | 1.72 | 1.72 | 0.49 | 13.9 | 3.60 | 2.76 | 1.03 | 61.2 | 3.43 | 2.98 | 0.98 | 55.5 | 4.24 | 2.53 | 1.22 | 85.0 | 6.68 | 3.41 | 1.92 | 210.8 |
| | 4 | 1.52 | 1.52 | 0.33 | 6.1 | 3.33 | 2.67 | 0.72 | 29.5 | 3.17 | 2.88 | 0.68 | 26.6 | 3.99 | 2.42 | 0.86 | 42.3 | 6.40 | 3.30 | 1.38 | 108.8 |
| | 5 | 1.31 | 1.31 | 0.22 | 2.9 | 3.04 | 2.58 | 0.52 | 15.8 | 2.89 | 2.78 | 0.50 | 14.2 | 3.70 | 2.31 | 0.64 | 23.3 | 6.15 | 3.17 | 1.06 | 64.4 |
| | 6 | 0.79 | 0.79 | 0.11 | 0.7 | 2.71 | 2.49 | 0.39 | 8.6 | 2.68 | 2.63 | 0.38 | 8.5 | 3.39 | 2.18 | 0.49 | 13.6 | 5.86 | 3.09 | 0.84 | 40.5 |
| | 7 | 0.65 | 0.65 | 0.08 | 0.4 | 2.40 | 2.40 | 0.29 | 5.0 | 2.47 | 2.47 | 0.30 | 5.3 | 3.08 | 2.05 | 0.38 | 8.2 | 5.57 | 2.97 | 0.68 | 26.9 |
| 13 | 3 | 1.48 | 1.48 | 0.42 | 10.3 | 3.15 | 2.64 | 0.90 | 46.7 | 2.97 | 2.86 | 0.85 | 41.5 | 3.82 | 2.39 | 1.10 | 69.1 | 6.26 | 3.27 | 1.79 | 184.8 |
| | 4 | 1.26 | 1.26 | 0.27 | 4.2 | 2.88 | 2.54 | 0.62 | 22.0 | 2.78 | 2.73 | 0.60 | 20.5 | 3.55 | 2.27 | 0.76 | 33.5 | 5.99 | 3.15 | 1.29 | 95.3 |
| | 5 | 0.91 | 0.91 | 0.16 | 1.4 | 2.57 | 2.51 | 0.44 | 11.2 | 2.60 | 2.60 | 0.45 | 11.5 | 3.27 | 2.16 | 0.56 | 18.2 | 5.72 | 3.02 | 0.98 | 55.7 |
| | 6 | 0.61 | 0.61 | 0.09 | 0.4 | 2.34 | 2.34 | 0.34 | 6.5 | 2.42 | 2.42 | 0.35 | 6.9 | 2.95 | 2.05 | 0.42 | 10.3 | 5.43 | 2.94 | 0.78 | 34.8 |
| | 7 | 0.45 | 0.45 | 0.05 | 0.2 | 2.14 | 2.14 | 0.26 | 4.0 | 2.22 | 2.22 | 0.27 | 4.3 | 2.58 | 1.93 | 0.32 | 5.8 | 5.14 | 2.82 | 0.63 | 23.0 |

Cooling capacity modification coefficient table:

| Speed | 250-B | | 300-B | | 400-B | | 500-B | | 600-B | |
|-------|-------|-----|-------|-----|-------|------|-------|------|-------|------|
| | TC | SC | TC | SC | TC | SC | TC | SC | TC | SC |
| High | 1 | 1 | 1 | 1 | 1 | 1 | 1 | 1 | 1 | 1 |
| Mid | 0.92 | 0.9 | 0.83 | 0.8 | 0.86 | 0.83 | 0.91 | 0.86 | 0.89 | 0.85 |
| Low | 0.82 | 0.8 | 0.71 | 0.7 | 0.73 | 0.7 | 0.78 | 0.75 | 0.79 | 0.75 |

S panel Heating Capacity

Δt: Temperature Difference (°C) **TH:** Total Heating Capacity (kW) **WF:** Water Flow (m³/h) **WPD:** Water Pressure Drop (kPa)

| TKG-250-B | | | | | | | | | | | | | | | | | | | | | | | | | |
|-------------------|------|---------------------------|-----|------|------|------|------|------|------|------|------|------|------|------|------|------|------|------|-------|------|-------|-------|------|-------|-----|
| Δt | | Air inlet temp. (20°C DB) | | | | | | | | | | | | | | | | | | | | | | | |
| | | Water inlet temp. (°C) | | | | | | | | | | | | | | | | | | | | | | | |
| | | 35 | | | 40 | | | 45 | | | 50 | | | 55 | | | 60 | | | 65 | | | 70 | | |
| | | TH | WF | WPD | TH | WF | WPD | TH | WF | WPD | TH | WF | WPD | TH | WF | WPD | TH | WF | WPD | TH | WF | WPD | TH | WF | WPD |
| 10 | 1.15 | 0.10 | 1.2 | 1.80 | 0.15 | 2.8 | 2.49 | 0.21 | 5.4 | 3.14 | 0.27 | 8.7 | 3.80 | 0.33 | 12.6 | 4.46 | 0.38 | 17.5 | 5.11 | 0.44 | 22.9 | 5.75 | 0.49 | 29.0 | |
| 8 | 1.27 | 0.14 | 2.2 | 1.98 | 0.21 | 5.4 | 2.65 | 0.28 | 9.6 | 3.31 | 0.36 | 15.0 | 3.94 | 0.42 | 21.3 | 4.58 | 0.49 | 28.8 | 5.23 | 0.56 | 37.4 | 5.87 | 0.63 | 47.2 | |
| 6 | 1.47 | 0.21 | 5.3 | 2.14 | 0.31 | 11.2 | 2.78 | 0.40 | 18.8 | 3.45 | 0.49 | 29.0 | 4.10 | 0.59 | 41.0 | 4.74 | 0.68 | 54.9 | 5.35 | 0.77 | 69.7 | 6.03 | 0.86 | 88.6 | |
| TKG-300-B | | | | | | | | | | | | | | | | | | | | | | | | | |
| Δt | | Air inlet temp. (20°C DB) | | | | | | | | | | | | | | | | | | | | | | | |
| | | Water inlet temp. (°C) | | | | | | | | | | | | | | | | | | | | | | | |
| | | 35 | | | 40 | | | 45 | | | 50 | | | 55 | | | 60 | | | 65 | | | 70 | | |
| | | TH | WF | WPD | TH | WF | WPD | TH | WF | WPD | TH | WF | WPD | TH | WF | WPD | TH | WF | WPD | TH | WF | WPD | TH | WF | WPD |
| 10 | 1.33 | 0.11 | 1.5 | 2.08 | 0.18 | 3.7 | 2.89 | 0.25 | 7.1 | 3.64 | 0.31 | 11.3 | 4.40 | 0.38 | 16.6 | 5.17 | 0.45 | 22.9 | 5.92 | 0.51 | 30.0 | 6.67 | 0.57 | 38.0 | |
| 8 | 1.47 | 0.16 | 2.9 | 2.29 | 0.25 | 7.0 | 3.07 | 0.33 | 12.6 | 3.83 | 0.41 | 19.6 | 4.57 | 0.49 | 27.9 | 5.31 | 0.57 | 37.7 | 6.06 | 0.65 | 49.1 | 6.81 | 0.73 | 61.9 | |
| 6 | 1.71 | 0.24 | 6.9 | 2.48 | 0.36 | 14.7 | 3.22 | 0.46 | 24.6 | 4.00 | 0.57 | 38.0 | 4.76 | 0.68 | 53.7 | 5.50 | 0.79 | 71.9 | 6.20 | 0.89 | 91.3 | 6.99 | 1.00 | 116.1 | |
| TKG-400-B | | | | | | | | | | | | | | | | | | | | | | | | | |
| Δt | | Air inlet temp. (20°C DB) | | | | | | | | | | | | | | | | | | | | | | | |
| | | Water inlet temp. (°C) | | | | | | | | | | | | | | | | | | | | | | | |
| | | 35 | | | 40 | | | 45 | | | 50 | | | 55 | | | 60 | | | 65 | | | 70 | | |
| | | TH | WF | WPD | TH | WF | WPD | TH | WF | WPD | TH | WF | WPD | TH | WF | WPD | TH | WF | WPD | TH | WF | WPD | TH | WF | WPD |
| 10 | 1.49 | 0.13 | 2.1 | 2.34 | 0.20 | 5.1 | 3.25 | 0.28 | 9.7 | 4.10 | 0.35 | 15.5 | 4.95 | 0.43 | 22.7 | 5.82 | 0.50 | 31.3 | 6.66 | 0.57 | 41.0 | 7.50 | 0.65 | 52.0 | |
| 8 | 1.66 | 0.18 | 4.0 | 2.58 | 0.28 | 9.6 | 3.46 | 0.37 | 17.3 | 4.31 | 0.46 | 26.8 | 5.14 | 0.55 | 38.2 | 5.98 | 0.64 | 51.6 | 6.82 | 0.73 | 67.1 | 7.66 | 0.82 | 84.7 | |
| 6 | 1.92 | 0.28 | 9.5 | 2.80 | 0.40 | 20.1 | 3.62 | 0.52 | 33.7 | 4.50 | 0.65 | 52.0 | 5.35 | 0.77 | 73.5 | 6.19 | 0.89 | 98.4 | 6.98 | 1.00 | 124.9 | 7.87 | 1.13 | 158.9 | |
| TKG-500G-B | | | | | | | | | | | | | | | | | | | | | | | | | |
| Δt | | Air inlet temp. (20°C DB) | | | | | | | | | | | | | | | | | | | | | | | |
| | | Water inlet temp. (°C) | | | | | | | | | | | | | | | | | | | | | | | |
| | | 35 | | | 40 | | | 45 | | | 50 | | | 55 | | | 60 | | | 65 | | | 70 | | |
| | | TH | WF | WPD | TH | WF | WPD | TH | WF | WPD | TH | WF | WPD | TH | WF | WPD | TH | WF | WPD | TH | WF | WPD | TH | WF | WPD |
| 10 | 1.99 | 0.17 | 1.6 | 3.13 | 0.27 | 3.9 | 4.33 | 0.37 | 7.5 | 5.46 | 0.47 | 11.9 | 6.60 | 0.57 | 17.4 | 7.76 | 0.67 | 24.1 | 8.88 | 0.76 | 31.5 | 10.00 | 0.86 | 40.0 | |
| 8 | 2.21 | 0.24 | 3.1 | 3.44 | 0.37 | 7.4 | 4.61 | 0.50 | 13.3 | 5.75 | 0.62 | 20.7 | 6.85 | 0.74 | 29.4 | 7.97 | 0.86 | 39.7 | 9.09 | 0.98 | 51.7 | 10.21 | 1.10 | 65.1 | |
| 6 | 2.56 | 0.37 | 7.3 | 3.73 | 0.53 | 15.4 | 4.83 | 0.69 | 25.9 | 6.00 | 0.86 | 40.0 | 7.13 | 1.02 | 56.5 | 8.25 | 1.18 | 75.7 | 9.30 | 1.33 | 96.1 | 10.49 | 1.50 | 122.3 | |
| TKG-600-B | | | | | | | | | | | | | | | | | | | | | | | | | |
| Δt | | Air inlet temp. (20°C DB) | | | | | | | | | | | | | | | | | | | | | | | |
| | | Water inlet temp. (°C) | | | | | | | | | | | | | | | | | | | | | | | |
| | | 35 | | | 40 | | | 45 | | | 50 | | | 55 | | | 60 | | | 65 | | | 70 | | |
| | | TH | WF | WPD | TH | WF | WPD | TH | WF | WPD | TH | WF | WPD | TH | WF | WPD | TH | WF | WPD | TH | WF | WPD | TH | WF | WPD |
| 10 | 2.29 | 0.20 | 2.0 | 3.59 | 0.31 | 4.9 | 4.98 | 0.43 | 9.4 | 6.28 | 0.54 | 14.9 | 7.59 | 0.65 | 21.8 | 8.93 | 0.77 | 30.1 | 10.21 | 0.88 | 39.4 | 11.50 | 0.99 | 50.0 | |
| 8 | 2.54 | 0.27 | 3.8 | 3.96 | 0.43 | 9.2 | 5.30 | 0.57 | 16.6 | 6.61 | 0.71 | 25.8 | 7.88 | 0.85 | 36.7 | 9.17 | 0.99 | 49.7 | 10.45 | 1.12 | 64.6 | 11.74 | 1.26 | 81.4 | |
| 6 | 2.94 | 0.42 | 9.1 | 4.29 | 0.61 | 19.3 | 5.56 | 0.80 | 32.4 | 6.90 | 0.99 | 50.0 | 8.20 | 1.18 | 70.7 | 9.49 | 1.36 | 94.6 | 10.70 | 1.53 | 120.1 | 12.06 | 1.73 | 152.8 | |

Heating capacity modification coefficient table:

| Speed | 250 | 300 | 400 | 500 | 600 |
|-------|------|------|------|------|------|
| | TH | TH | TH | TH | TH |
| High | 1 | 1 | 1 | 1 | 1 |
| Mid | 0.86 | 0.88 | 0.89 | 0.90 | 0.90 |
| Low | 0.74 | 0.75 | 0.75 | 0.76 | 0.75 |

Altitude modification coefficient table:

| Altitude | TC | SC | TH |
|----------|------|------|------|
| 500 | 0.98 | 0.95 | 0.95 |
| 1000 | 0.97 | 0.91 | 0.91 |
| 1500 | 0.95 | 0.86 | 0.86 |
| 2000 | 0.94 | 0.82 | 0.82 |
| 2500 | 0.93 | 0.78 | 0.78 |
| 3000 | 0.91 | 0.74 | 0.70 |

11. Sound Levels

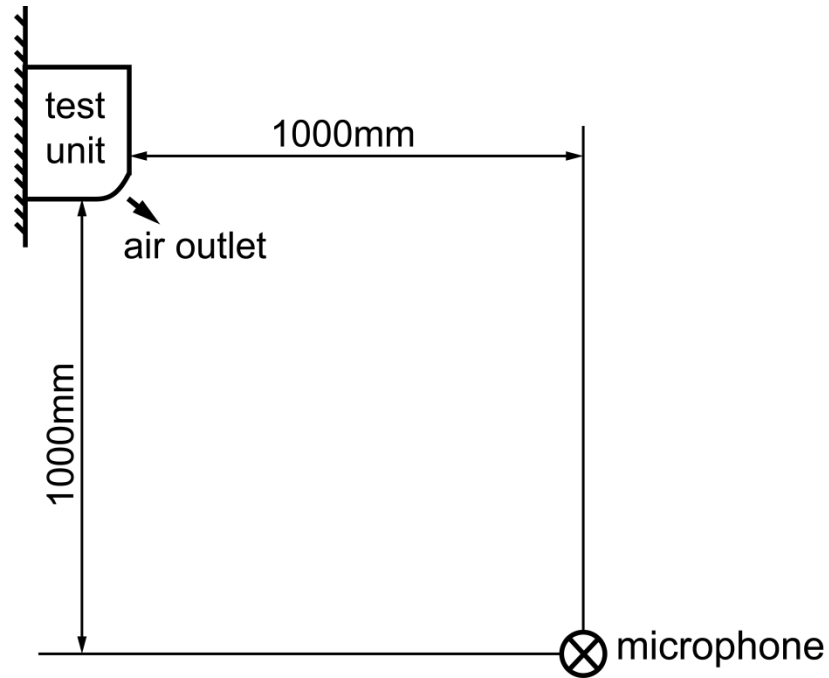

| Series | Model | Noise level under three speeds of fan [dB(A)] | | |
|---------|-----------|---|----|----|
| | | H | M | L |
| C panel | TKG-250 | 30 | 24 | 20 |
| | TKG-300 | 35 | 29 | 24 |
| | TKG-400 | 37 | 31 | 26 |
| | TKG-500 | 39 | 33 | 28 |
| | TKG-600 | 40 | 34 | 29 |
| S panel | TKG-250-B | 30 | 24 | 20 |
| | TKG-300-B | 35 | 29 | 24 |
| | TKG-400-B | 37 | 31 | 26 |
| | TKG-500-B | 39 | 33 | 28 |
| | TKG-600-B | 40 | 34 | 29 |

12. Exploded View

C panel

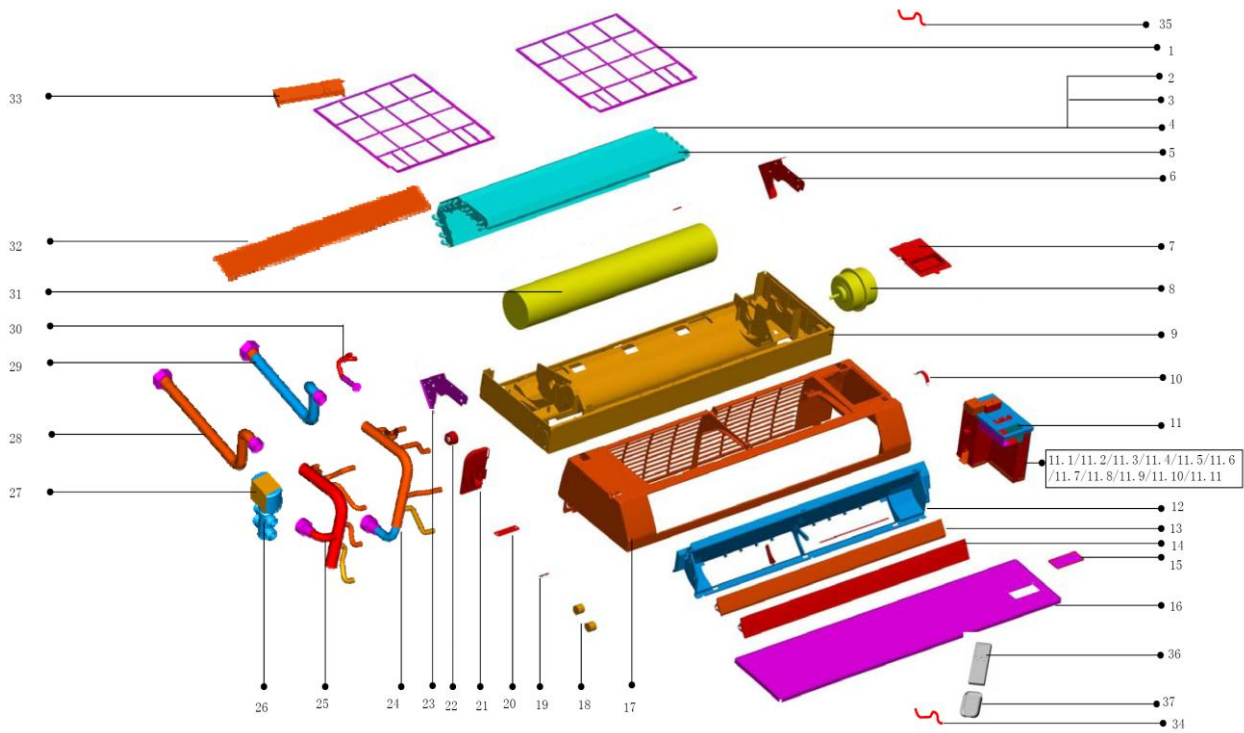

| No. | Part Name | Quantity | No. | Part Name | Quantity |
|-------|---------------------------------------|----------|-----|--------------------------------|----------|
| 1 | Filter | 2 | 14 | Louver | 1 |
| 2 | Evaporator I | 1 | 15 | Panel dalle | 1 |
| 3 | Evaporator II | 1 | 16 | Panel | 1 |
| 4 | Evaporator III | 1 | 17 | Panel frame ass'y | 1 |
| 5 | Coil temp sensor | 1 | 18 | Stepper motor | 2 |
| 6 | Evaporate connect board | 1 | 19 | Screw cover | 3 |
| 7 | Display board ass'y | 1 | 20 | Pipe clamp | 1 |
| 8 | Motor | 1 | 21 | Drainage pan | 1 |
| 9 | Base pan assembly | 1 | 22 | Bearing base | 1 |
| 10 | Motor spud | 2 | 23 | Evaporator left clapboard | 1 |
| 11 | E-part box ass'y | 1 | 24 | Water inlet pipe ass'y | 1 |
| 11.1 | Dial code switch box cover | 1 | 25 | Water outlet pipe ass'y | 1 |
| 11.2 | Electric control box seat | 1 | 26 | Three-way valve | 1 |
| 11.3 | E-Part box cover | 1 | 27 | Control wire for 3-Ways valve | 1 |
| 11.4 | Electric control box soleplate | 1 | 28 | Outlet screw pipe ass'y | 1 |
| 11.5 | Electric control box side board ass'y | 1 | 29 | Inlet screw pipe ass'y | 1 |
| 11.6 | Dial code switch board ass'y | 1 | 30 | Discharge valve | 1 |
| 11.7 | Main controller ass'y | 1 | 31 | Cross fan | 1 |
| 11.8 | Transformer | 1 | 32 | Base pan holder | 1 |
| 11.9 | Wire joint | 1 | 33 | Formaldehyde killer | 1 |
| 11.10 | Wire joint, 3p | 1 | 34 | Room Temperature Sensor Ass'y | 1 |
| 11.11 | Motor capacitor | 1 | 35 | Network matching wire | 1 |
| 12 | Air outlet frame mount ass'y | 1 | 36 | Remote controller | 1 |
| 13 | Louver board | 1 | 37 | Remote controller holder ass'y | 1 |

S panel

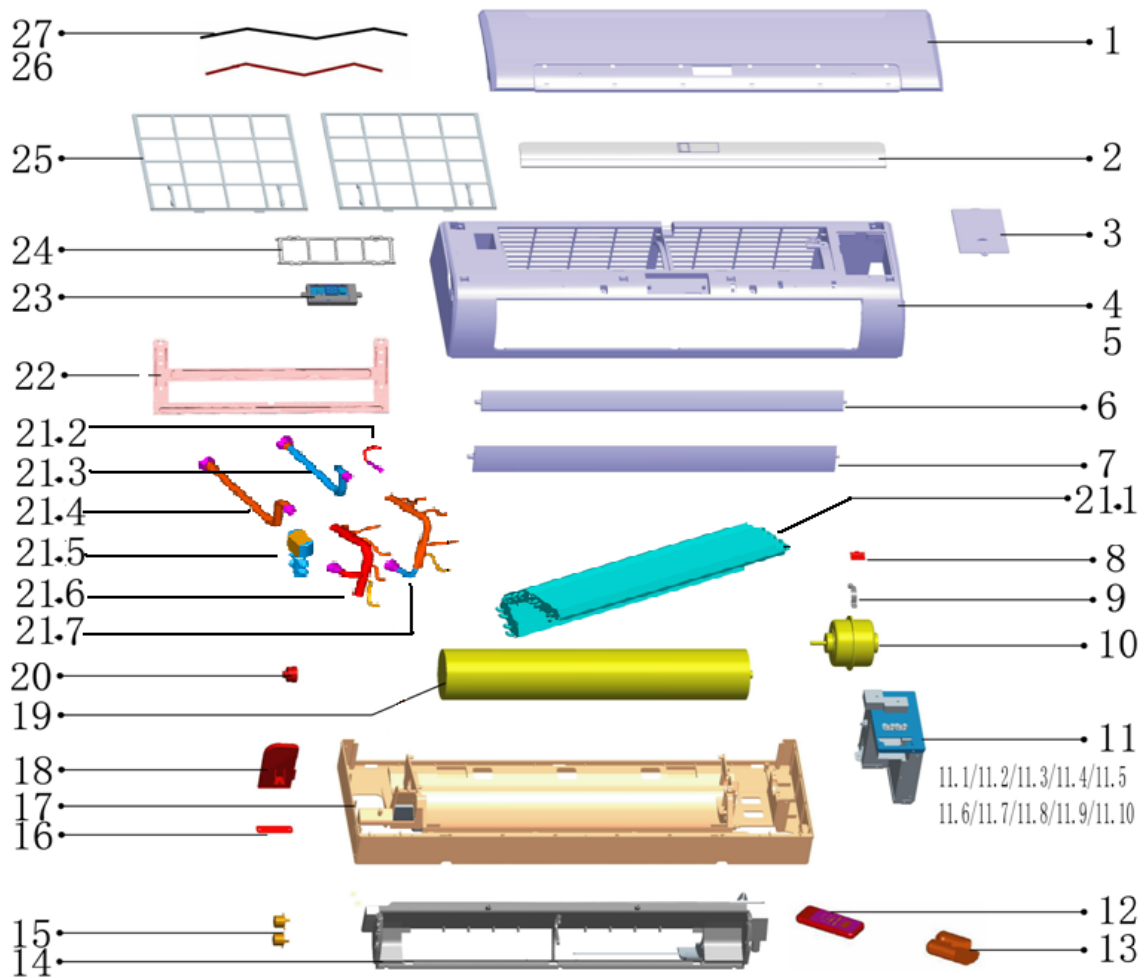

| No. | Part Name | Quantity | No. | Part Name | Quantity |
|-------|---------------------------------|----------|-------|----------------------------|----------|
| 1 | Panel ass'y | 1 | 16 | Pipe clamp | 1 |
| 2 | Panel decorative plates | 1 | 17 | Chassis ass'y | 1 |
| 3 | Electrical cover | 1 | 18 | Drainage pan ass'y | 1 |
| 4 | Panel frame ass'y | 1 | 19 | Cross fan | 1 |
| 5 | Screw cover | 3 | 20 | Bearing block | 1 |
| 8 | Sealing plug | 2 | 21 | Evaporator ass'y | 1 |
| 9 | Motor spud | 2 | 21.1 | Evaporator | 1 |
| 10 | Motor | 1 | 21.2 | Evaporator | 1 |
| 11 | E-part box ass'y | 1 | 21.3 | Evaporator | 1 |
| 11.1 | Electric control box base | 1 | 21.4 | Evaporate connecting board | 1 |
| 11.2 | Electric control box side panel | 1 | 21.5 | Evaporate connecting board | 1 |
| 11.3 | electric control box cover | 1 | 21.8 | Water-outlet pipe ass'y | 1 |
| 11.4 | Dial switch cover label | 1 | 21.9 | Water-inlet pipe ass'y | 1 |
| 11.5 | Dial code switch board ass'y | 1 | 21.10 | 3-Way valve | 1 |
| 11.7 | Terminal block, 5p | 1 | 21.11 | Discharge valve | 1 |
| 11.8 | Main control board ass'y | 1 | 22 | Installation board ass'y | 1 |
| 11.9 | Terminal block, 3p | 1 | 23 | Display board ass'y | 1 |
| 11.10 | Capacitor | 1 | 24 | Air purify net | 1 |
| 12 | Remote controller | 1 | 25 | Filter network | 2 |
| 13 | Remote controller bracket | 1 | 26 | Pipe temp. sensor ass'y | 1 |
| 14 | Air outlet frame | 1 | 27 | Room temp sensor ass'y | 1 |
| 15 | Stepper motor | 1 | | | |

13. Installation

13.1 Installation Attention

※ **Warning:**

- **Be sure only trained and qualified service personnel to install, repair or service the equipment.**
Improper installation, repair, and maintenance may result in electric shocks, short-circuit, leaks, fire or other damage to the equipment.
 - **Install according to this installation instructions strictly.**
 - **If installation is defective, it will cause water leakage, electrical shock and fire.**
 - **When installing the unit in a small room, take measures against to keep water concentration from exceeding allowable safety limits in the event of water leakage.**
Contact the place of purchase for more information.
 - **Use the attached accessories parts and specified parts for installation.**
Otherwise, it will cause the set to fall, water leakage, electrical shock fire.
 - **Install at a strong and firm location which is able to withstand the set's weight.**
If the strength is not enough or installation is not properly done, the set will drop to cause injury.
 - **The appliance must be installed 2.3m above floor.**
 - **The appliance shall not be installed in the laundry.**
 - **Before obtaining access to terminals, all supply circuits must be disconnected.**
 - **The appliance must be positioned so that the plug is accessible.**
 - **The enclosure of the appliance shall be marked by word, or by symbols, with the direction of the fluid flow.**
 - **For electrical work, follow the local national wiring standard, regulation and this installation instruction. An independent circuit and single outlet must be used.**
If electrical circuit capacity is not enough or defect in electrical work, it will cause electrical shock fire.
 - **Use the specified cable and connect tightly and clamp the cable so that no external force will be acted on the terminal.**
If connection or fixing is not perfect, it will cause heat-up or fire at the connection.
 - **Wiring routing must be properly arranged so that control board cover is fixed properly.**
 - **If control board cover is not fixed perfectly, it will cause heat-up at connection point of terminal, fire or electrical shock.**
If the supply cord is damaged, it must be replaced by the manufacture or its service agent or a similarly qualified person in order to avoid a hazard.
 - **An all-pole disconnection switch having a contact separation of at least 3mm in all poles should be connected in fixed wiring.**
 - **Do not modify the length of the power supply cord or use of extension cord, and do not share the single outlet with other electrical appliances.**
Otherwise, it will cause fire or electrical shock.
 - **Carry out the specified installation work after taking into account strong winds, typhoons or earthquakes.**
Improper installation work may result in the equipment falling and causing accidents.
 - **If the water leaks during installation, ventilate the area immediately.**
 - **After completing the installation work, check that water does not leak.**
- ※ **Caution:**
- **Ground the air conditioner.**
Do not connect the ground wire to gas or water pipes, lightning rod or a telephone ground wire. Incomplete grounding may result in electric shocks.
 - **Be sure to install an earth leakage breaker.**
Failure to install an earth leakage breaker may result in electric shocks.
 - **Connect the outdoor unit wires, then connect the indoor unit wires.**

You are not allowed to connect the air conditioner with the power source until wiring and piping the air conditioner is done.

- **While following the instructions in this installation manual, install drain piping in order to ensure proper drainage and insulate piping in order to prevent condensation.**

Improper drain piping may result in water leakage and property damage.

- **Install the indoor and outdoor units, power supply wiring and connecting wires at least 1 meter away from televisions or radios in order to prevent image interference or noise.**

Depending on the radio waves, a distance of 1 meter may not be sufficient enough to eliminate the noise.

- **The appliance is not intended for use by young children or infirm persons without supervision.**













- **Don't install the air conditioner in the following locations:**

- There is petrolatum existing.
- There is salty air surrounding (near the coast).
- There is caustic gas (the sulfide, for example) existing in the air (near a hot spring).
- The Volt vibrates violently (in the factories).
- In buses or cabinets.
- In kitchen where it is full of oil gas.
- There is strong electromagnetic wave existing.
- There are inflammable materials or gas.
- There is acid or alkaline liquid evaporating.
- Other special conditions.

※ **Installation Order:**

- Select the location;
- Install the indoor unit;
- Install the outdoor unit;
- Connect the drain pipe;
- Wiring;
- Test operation.



13.2 Accessory

| Name | Shape | Quantity | Function |
|--|---|----------|---|
| Installation board |  | 2 | _____ |
| Screw ST3.9x25 for installation board |  | 3 | Secure the installation board |
| Plastic expanded tube |  | 3 | _____ |
| Wrapping tape |  | 1 | _____ |
| Drain pipe |  | 2 | _____ |
| Sealing clay |  | 2 | _____ |
| Wall conduit cover |  | 1 | _____ |
| Remote controller (including operation manual) |  | 1 | _____ |
| Frame |  | 1 | Hold the remote controller |
| Mounting screw(ST2.9x10-C-H) |  | 2 | Insulation Holder for remote controller |
| Alkaline dry batteries (AM4) |  | 2 | _____ |
| Owner's manual | _____ | 1 | _____ |
| Installation manual | _____ | 1 | _____ |
| 12. seel gasket |  | 4 | For connecting water pipe |

13.3 Inspecting and Handling the unit

At delivery, the package should be checked and any damage should be reported immediately to the carrier claims agent.

When handling the unit, take into account the following:

-  Fragile, handle the unit with care.
-  Keep the unit upright in order to avoid compressor damage.
- Choose on beforehand the path along which the unit is to be brought in.
- Move this unit as originally package as possible.
- When lifting the unit, always use protectors to prevent belt damage and pay attention to the position of the unit's centre of gravity.

13.4 Indoor Unit Installation

13.4.1 Installation place

Installation in the following places may cause trouble. If it is unavoidable, please consult with the local dealer.

- A place full of machine oil.
- A saline place such as coast.
- A place full of sulfide gas such as hot-spring resort.
- Places where there are high frequency machines such as wireless equipment, welding
- Machine and medical facility.
- A place there is no combustive gases and volatile matter.
- A place of special environmental conditions.

Installation in the following places:

- ✓ A place where is no obstacle near the inlet and outlet area.
- ✓ A place which can bear the indoor unit.

- ✓ A place which is convenient to maintenance.
- ✓ A place which provides the space around the indoor unit as required right in the diagram.
- ✓ There is strong electromagnetic wave existing.
- ✓ A place which is far from heat, steam and inflammable gas.

13.4.2 Drilling A Hole and Mounting Installation Board

Installation Board and Its Direction (unit: mm)

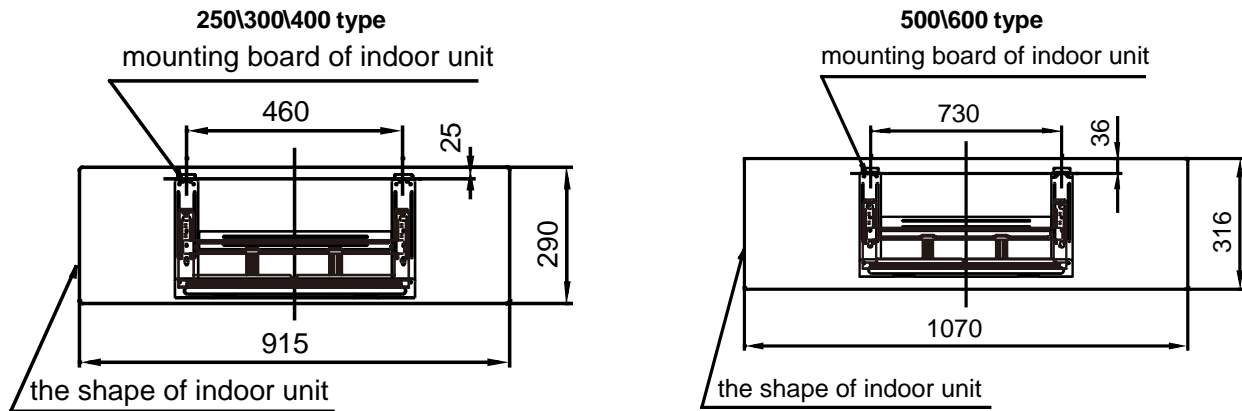

■ **Fix the installation board**

- Install the installation board horizontally on structural parts on the wall with the spaces provided around the plate.
- In case of brick, concrete or similar type walls, make 5mm dia. holes on the wall. Insert clip anchors for appropriate mounting screws.
- Fix the installation board on the wall.

Right installation

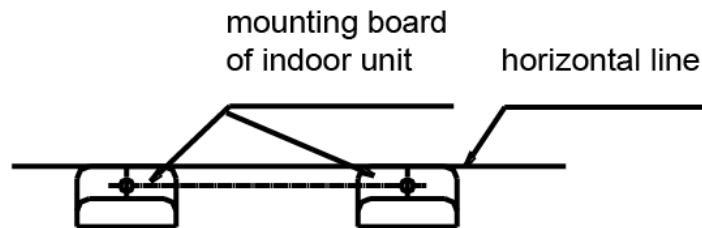

False installation

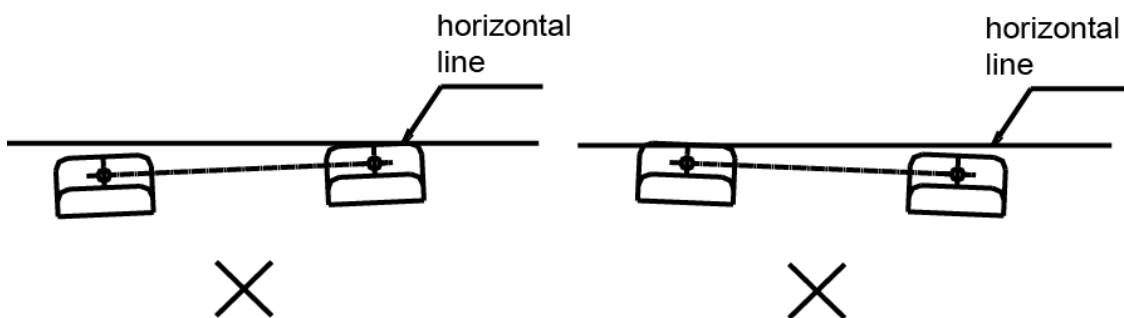

■ **Drilling a hole**

- Determine the pipe hole position using the installation board, and drill the pipe hole (N95mm) so it slants slightly downward.
- Always use a wall hole conduit when piercing metal lath, ply wood or metal plate.

13.4.3 Connective Pipe and Drainage Installation

■ **Drainage**

Run the drain hose sloping downward. Do not install the drain hose as illustrated below.

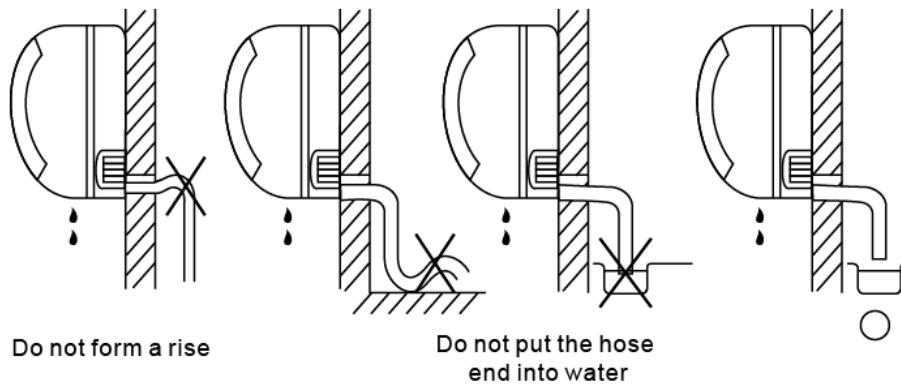

When connection extension drain hose, insulate the connecting part of extension drain hose with a shield pipe.

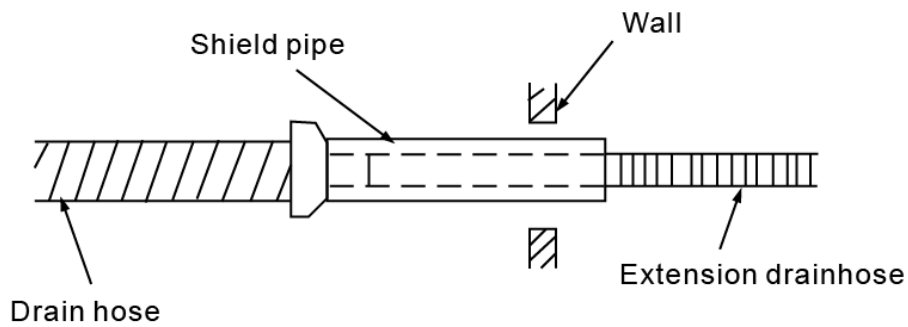

■ Connection pipe

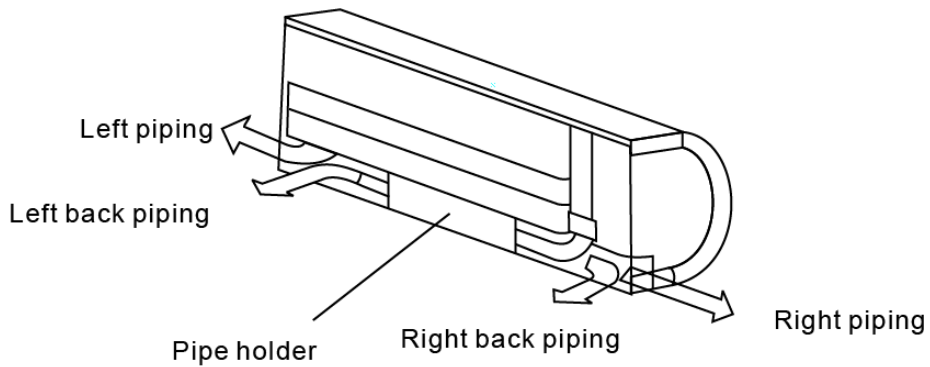

1. When install the water pipe of G unit, please following it

a) Put down two screws between the pipe holder and unit, and then get down pipe holder. (Refer to the following fig)

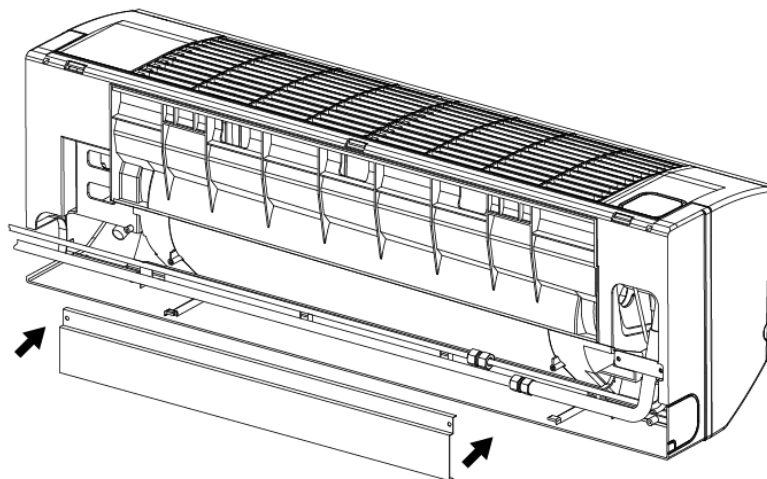

- b) Connect pipe.
- c) Install the pipe holder. (Refer to the following fig)

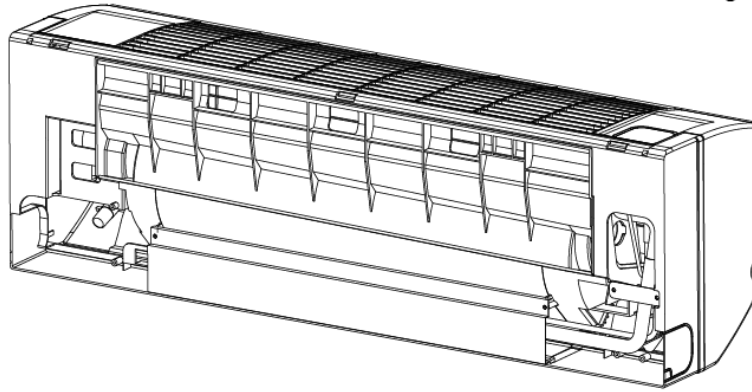

2. For the left-hand and rear-left-hand piping, install the piping as shown. Bend the connective pipe to be laid at 43mm height or less from the wall.

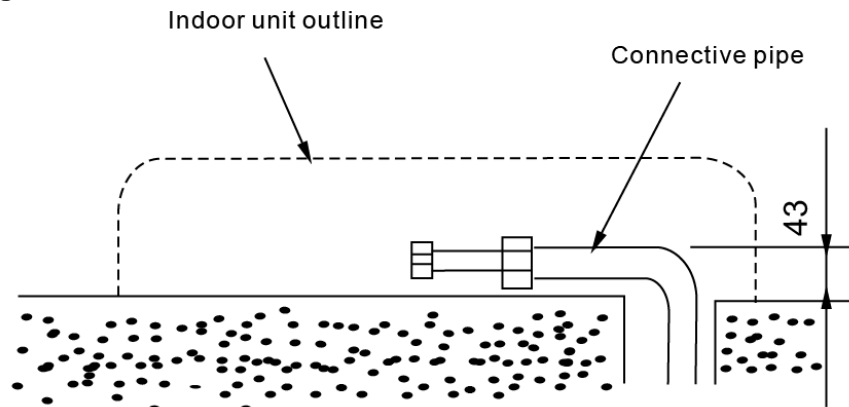

3. Fix the end of the connective pipe.

Caution:

- Connect the indoor unit first then the outdoor unit and bend and arrange the pipe carefully.
- Do not allow the piping to let out from the back of the indoor unit.
- Be careful not to let the drain hose slack.
- Insulate both of the auxiliary piping.
- Banding the drain hose under the auxiliary pipe.
- Do not allow the piping to let out from the back of the indoor unit.

■ **Piping and bandaging**

Wind the connective cable, drain hose and wiring with tape securely, evenly as shown below.

Because the condensed water from rear of the indoor unit is gathered in Pond Box and is piped out of room. Do not put anything else in the box.

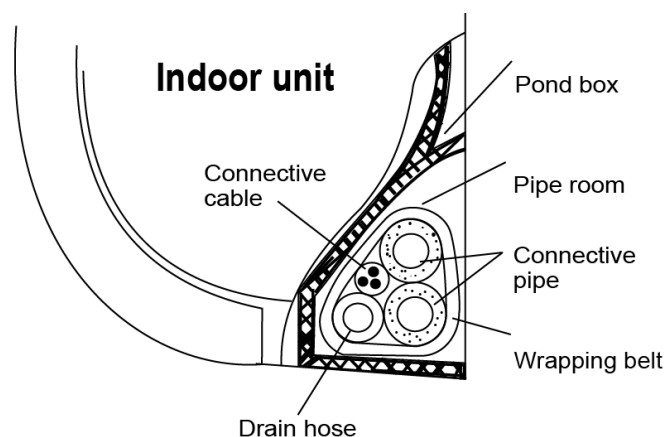

13.4.4 Indoor Unit Installation

- Pass the piping through the hole in the wall.
- Put the claw at the back of the indoor unit on the hook of the installation board, move the Indoor Unit from side to

side to see that it is securely hooked.

- Piping can easily be made by lifting the indoor unit with a cushioning material between the indoor unit and the wall. Get it out after finish piping.
- Push the lower part of the Indoor Unit up to the wall, then move the Indoor Unit from side to side, up and down to check if it is hooked securely.

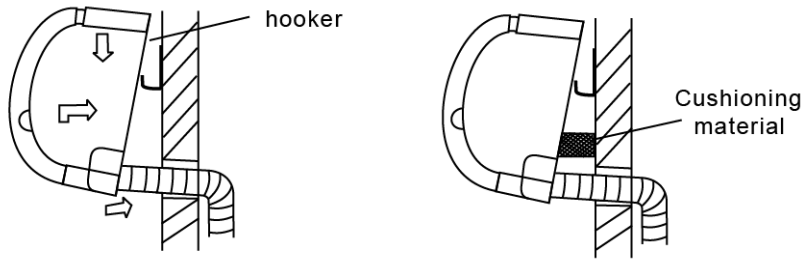

13.5 Water Pipe Installation

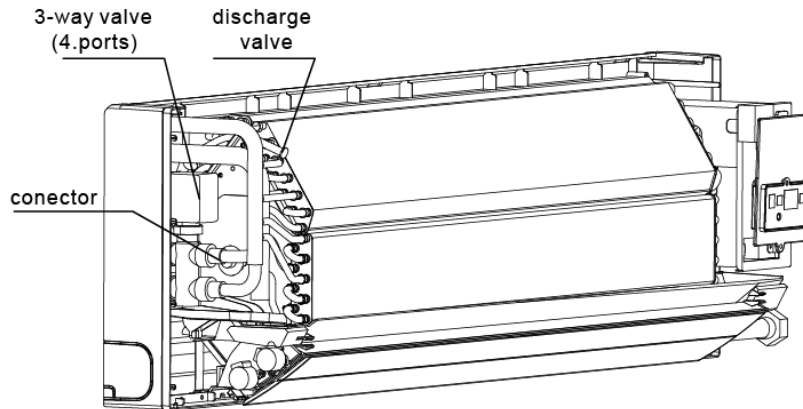

Material and Size of the Piping

| Pipe material | Copper Pipe for Air Conditioner | |
|-------------------------------|---------------------------------|---------|
| Model | 250/300/400 | 500/600 |
| Coil connections (flat plate) | 3/4" | 3/4" |
| | 3/4" | 3/4" |

Connection of the water pipe should be done by professionals. Double-span should be used when connecting pipes of Indoor Unit.

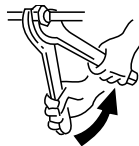

At the first debugging, completely expel air from coils via expelling valve.

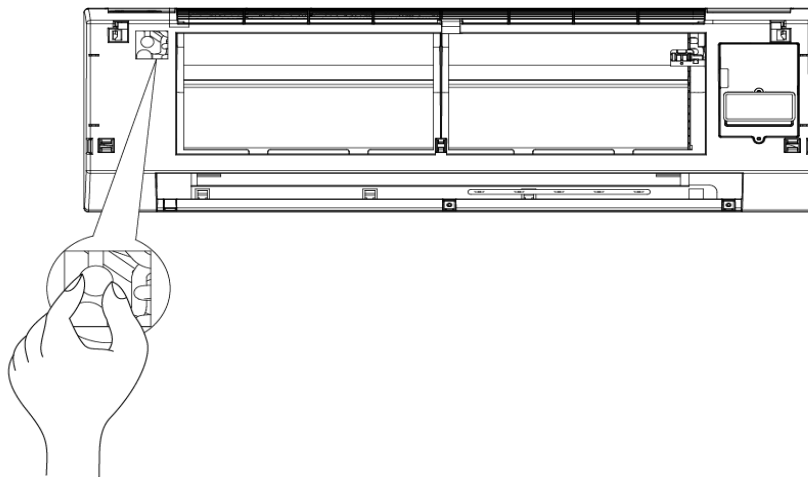

13.6 Wiring

Cautions:

- The reserved function is indicated in broken line table, users can select it when necessary.
- An all-pole disconnection device which has at least 3mm separation distance in all pole and a residual current device (RCD) with the rating of above 10mA shall be incorporated in the fixed wiring according to the national rule.
- The appliance shall be installed in accordance with national wiring regulations.

Take out the faceplate, and then dismantle the display cover.

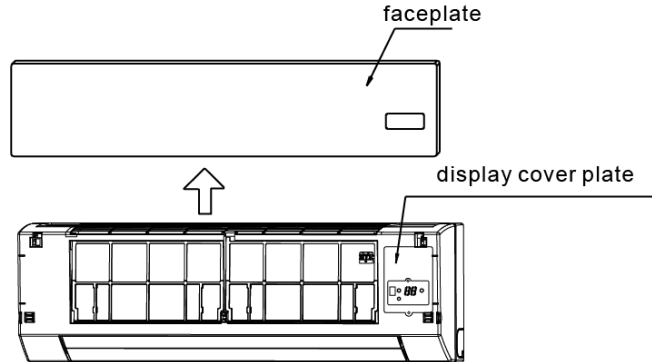

Individual connect the power cord and signal line, adjust the dial switch.

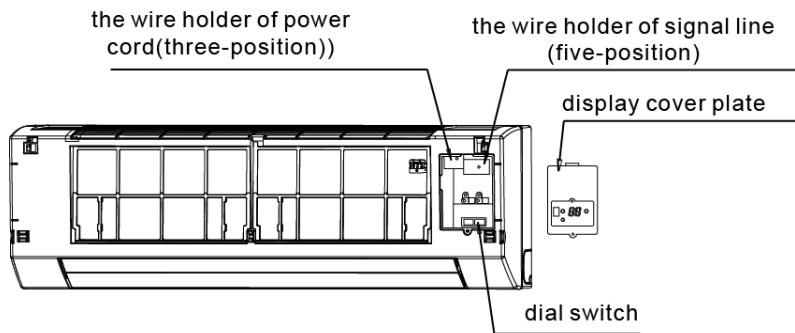

13.6.1 Terminal Board Diagram

The wiring diagram please refers to chapter 9.

Note:

The air-conditioners can connect with Central Control Monitor (CCM). Before operation, please wiring correctly and set system address and network address of indoor units.

Single phase indoor unit:

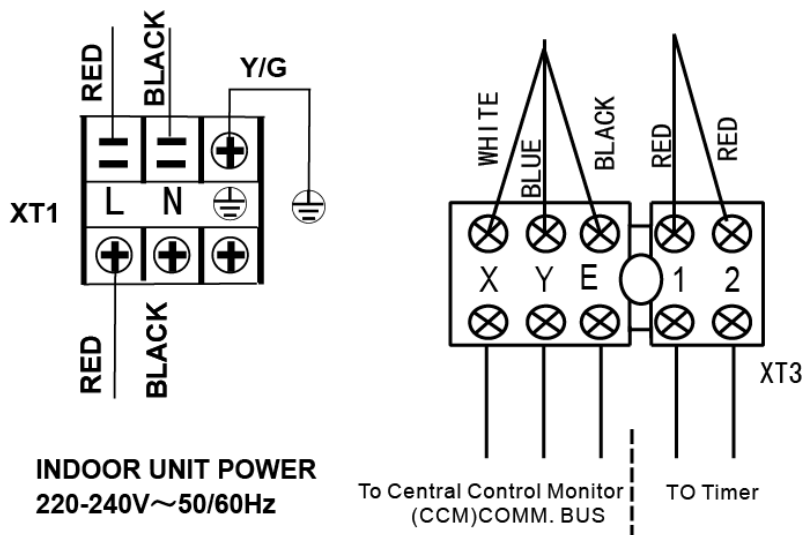

Please adopt the shielded twisted-pair wire, and connect the shielded layer to E

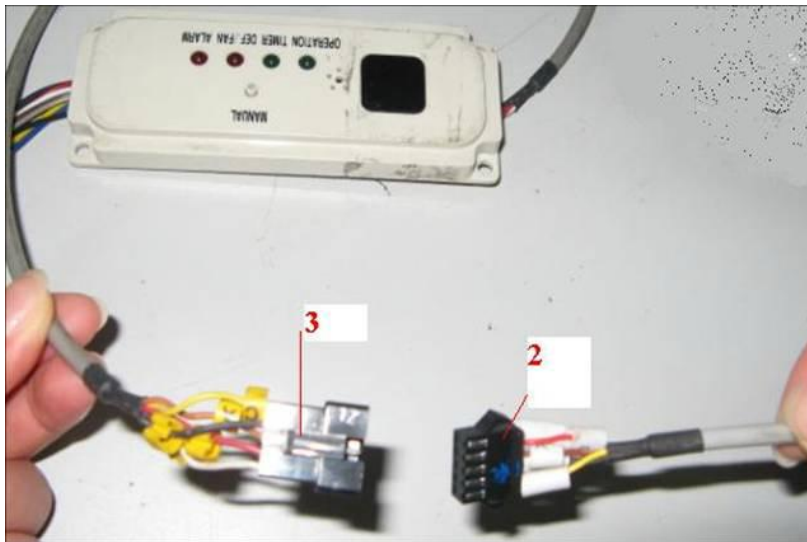
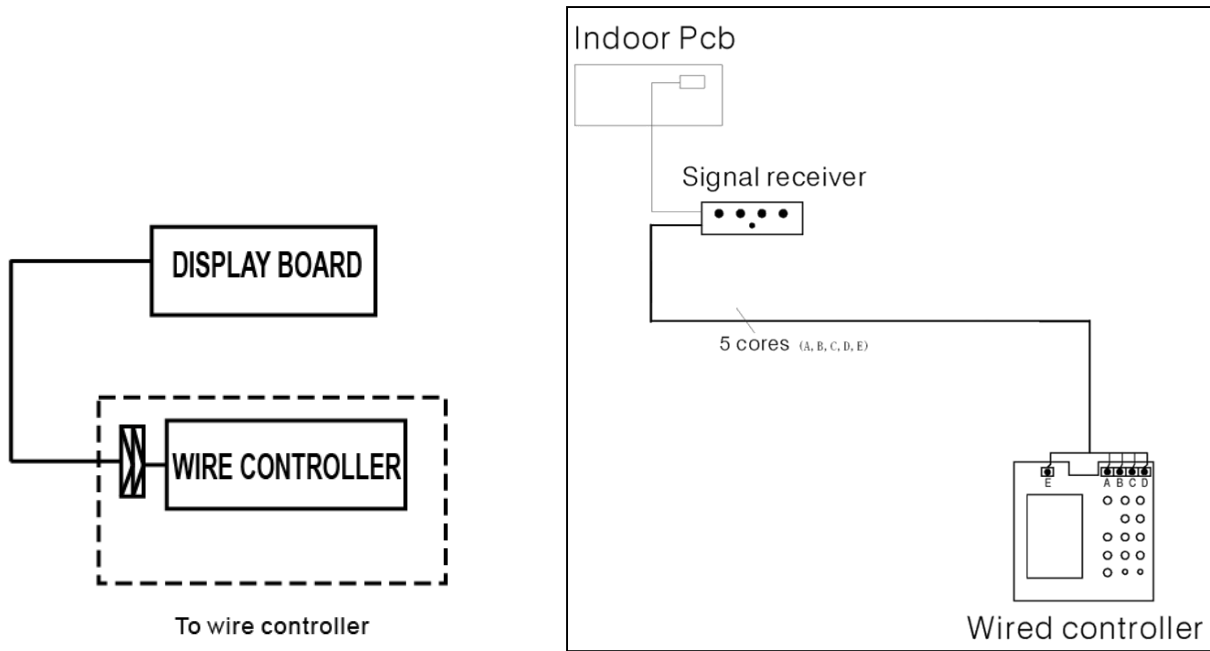

Insert 2 & 3 together is OK

The reserved wire control function is indicated in broken line table, users can purchase the wire controller when necessary.

13.6.2 Network address set

Every air-conditioner in network has only one network address to distinguish each other. Address code of air-conditioner in LAN is set by code switch on Network Interface Module (NIM), and the set range is 0-63.

| Toggle switch set | | Network address code |
|-------------------|------|----------------------|
| SW1 | ENC2 | |
| | | 00~15 |
| | | 16~31 |
| | | 32~47 |
| | | 48~63 |

13.7 Trouble-shooting

| Malfunction code | Malfunction |
|------------------|----------------------------------|
| EE | DC motor malfunction |
| E3 | T2 evaporator sensor malfunction |
| E2 | T1 evaporator sensor malfunction |
| E8 | Water-level alarm malfunction |
| E7 | EEPROM communication error |

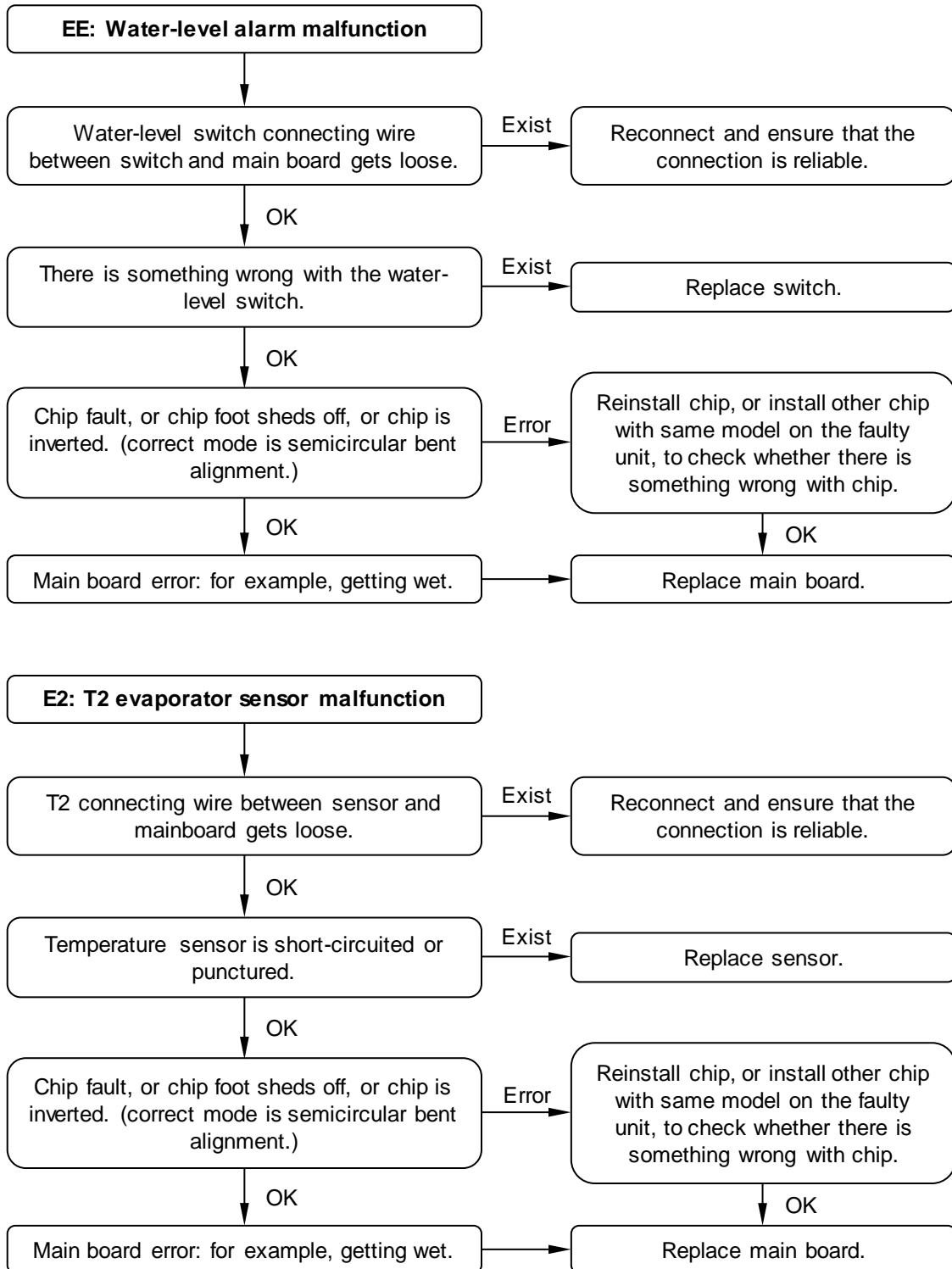

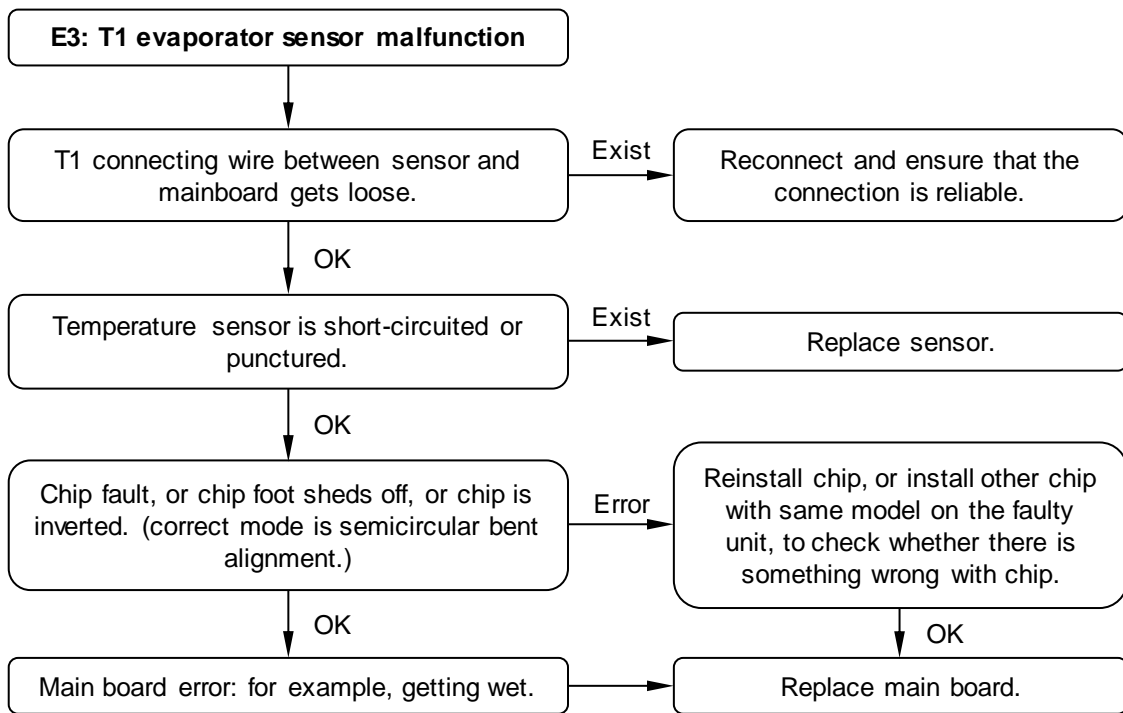

13.7.1 Troubles and causes of air conditioner

If one of the following malfunctions occur, stop operation, shut off the power, and contact with your dealer.

- The operation lamp is flashing rapidly (twice every second)
- This lamp is still flashing rapidly after turn off the power and turn on again.
- Remote controller receives malfunction or the button does not work well.
- A safety device such as a fuse, a breaker frequently actuates.
- Water leaks from indoor unit.
- Other malfunctions.

| Symptoms | Causes | Solution |
|---|---|--|
| Unit does not start | <ul style="list-style-type: none"> • Power failure; • Power switch is off; • Fuse of power switch may have burned; • Batteries of remote controller exhausted or other problem of controller. | <ul style="list-style-type: none"> • Wait for the comeback of power; • Switch on the power; • Replace the fuse; • Replace the batteries or check the controller. |
| Air flowing normally but completely can't cooling | <ul style="list-style-type: none"> • Temperature is not set correctly. | <ul style="list-style-type: none"> • Set the temperature properly. |
| Low cooling effect | <ul style="list-style-type: none"> • Indoor unit heat exchanger is dirty; • The air filter is dirty; • Inlet of indoor unit is blocked; • Doors and windows are open; • Sunlight shine directly; • Too many heat resources; • Outdoor temperature is too high. | <ul style="list-style-type: none"> • Clean the heat exchanger; • Clean the air filter; • Eliminate all dirties and make air smooth; • Close doors and windows; • Make curtains in order to shelter from sunshine; • Reduce heat resource; • AC cooling capacity reduces (normal). |
| Low heating effect | <ul style="list-style-type: none"> • Outdoor temperature is lower than 7°C; • Doors and windows are not completely closed. | <ul style="list-style-type: none"> • Use heating device; • Close doors and windows. |

13.7.2 Troubles and causes of remote controller

Before asking for serving or repairing, check the following points.

| Symptoms | Causes | Solution |
|--|--|---|
| The fan speed can not be changed. | <ul style="list-style-type: none"> Check whether the MODE indicated on the display is "AUTO". | When the automatic mode is selected, the air conditioner will automatically change the fan speed. |
| | <ul style="list-style-type: none"> Protection against hot wind in cooling mode. Protection against cold wind in heating mode. | Reduce the temperature of inlet in cooling mode rise the temperature of inlet in heating mode. |
| The remote controller signal is not transmitted even when the ON/OFF button is pushed. | <ul style="list-style-type: none"> Check whether the batteries in the remote controller are exhausted. | The power supply is off. |
| The TEMP. indicator does not come on. | <ul style="list-style-type: none"> Check whether the MODE indicated on the display is "FAN ONLY". | The temperature cannot be set during FAN mode. |
| The indication on the display disappears after a lapse of time. | <ul style="list-style-type: none"> Check whether the timer operation has come to an end when the "TIMER OFF" is indicated on the display. | The air conditioner operation will stop up to the set time. |
| The TIMER ON indicator goes off after a lapse of certain time. | <ul style="list-style-type: none"> Check whether the timer operation is started when the "TIME ON" is indicated on the display. | Up to the set time, the air conditioner will automatically start and the appropriate indicator will go off. |
| No receiving tone sounds from the indoor unit even when the ON/OFF button is pressed. | <ul style="list-style-type: none"> Check whether the signal transmitter of the remote controller is properly directed to the infrared signal receiver of the indoor unit when the ON/OFF button is pressed. | Directly transmit the signal transmitter of the remote controller to the infrared signal receiver of the indoor unit, and then repeatedly push the ON/OFF button twice. |

14. Controller

14.1 Wireless remote controller R51/E

■ Remote Controller Specifications

| | |
|---------------------------------------|---|
| Model | R51/E |
| Rated Voltage | 3.0V |
| Lowest Voltage of CPU Emitting Signal | 2.0V |
| Reaching Distance | 8m (when using 3.0 voltage, it can get 11m) |
| Environment Temperature Range | -5°C~60°C |

■ Introduction of Function Buttons on the Remote Controller

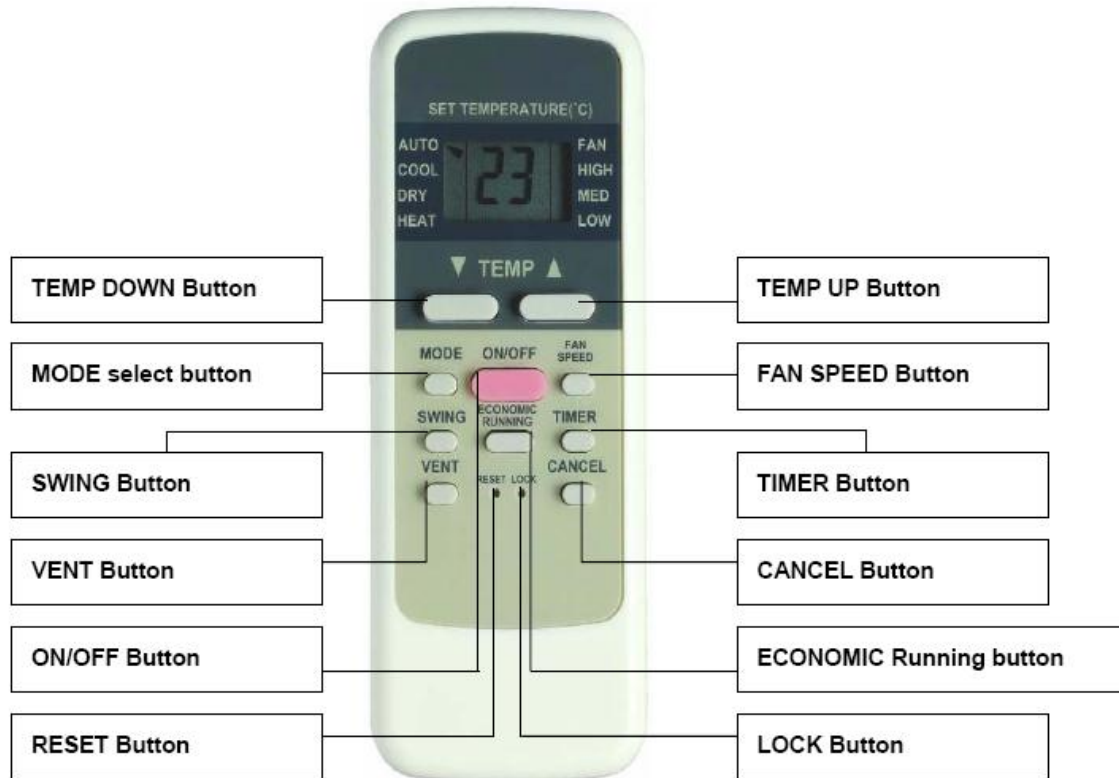

1. **TEMP DOWN Button:** Push the TEMP DOWN button to decrease the indoor temperature setting or to adjust the timer in a counter-clockwise direction.
2. **MODLE SELECT Button:** Each time you push the button, a mode is selected in a sequence that goes from AUTO, COOL, DRY, HEAT and FAN as the following figure indicates:

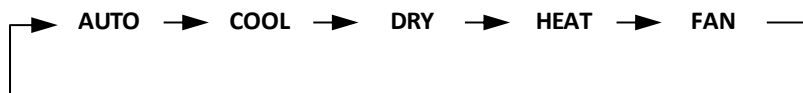

Note: HEAT only for Heat Pump.

3. **SWING Button:** Push this switch button to change the louver angle.
4. **RESET Button:** When the RESET button is pushed, all of the current settings are cancelled and the control will return to the initial settings.
5. **ECONOMIC RUNNING Button:** Push this button to go into the Energy-Saving operation mode.
6. **LOCK Button:** Push this button to lock in all the current settings. To release settings, push again.
7. **CANCEL Button:** Push this button to cancel the TIMER settings.
8. **TIMER Button:** This button is used to preset the time ON (start to operate) and the time OFF (turn off the operation)
9. **ON/OFF Button:** Push this button to start the unit operation. Push the button again to stop the unit operation.
10. **FAN SPEED Button:** This button is used for setting fan speed in the sequence that goes from AUTO, LOW, MED to HIGH, and then back to Auto.
11. **TEMP UP Button:** Push this button to increase the indoor temperature setting or to adjust the timer in a counter-clockwise direction.
12. **VENT Button:** Push this button to set the ventilating mode. The ventilating mode will operate in the following sequence:

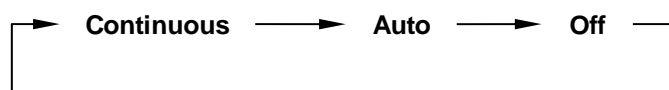

Note: Ventilation Function is available for the Fresh Star Series.

■ Introduction of Indicators

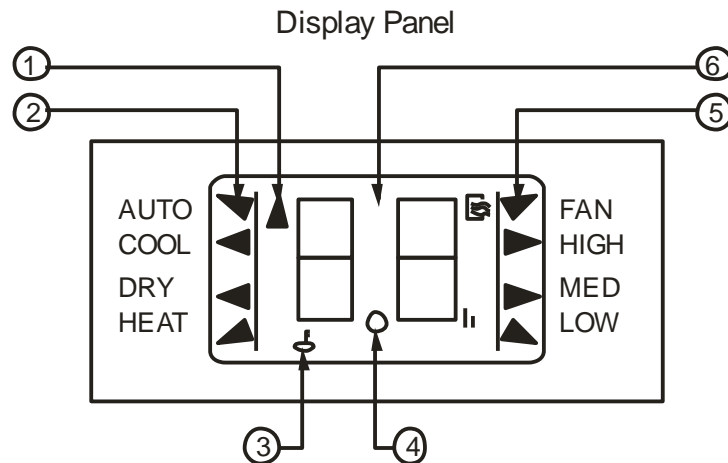

1. **TRANSMISSION Indicator:** This indicator lights when remote controller transmits signals to indoor unit.
2. **MODE Display:** Shows the current operation mode - AUTO, COOL, DRY or HEAT. HEAT only available for heat pump model.
3. **HEAT PUMP ONLY- LOCK display** is displayed by pushing the LOCK button. Push the LOCK button again to clear display.
4. **TIMER Display:** This display area shows the settings of TIMER. That is, if only the starting time of operation is set, it will display the TIMER ON. If only the turning off time of operation is set, it will display the TIMER OFF. If both operations are set, it will show TIMER ON OFF which indicates you have chosen to set both the starting time and off time.
5. **FAN Display:** When the FAN button is pushed, this signal indicator lights.
6. **Digital Display Area:** This area will show the temperature, and if in the TIMER mode, it will show the ON and OFF settings of the TIMER.

Note: All items are shown in the Fig for the purpose of clear presentation, But during the actual operation only the relative functional items are shown on the display panel.

■ Operational Guidelines

Operating the Remote Controller

- **Install / Replace Batteries:** The Remote Controller uses two alkaline dry batteries(R03/Ir03×2).
 1. To install batteries, slide back the cover of the battery compartment and install the batteries according to the directions (+and -) shown on the Remote Controller.
 2. To replace the old batteries , use the same method as mentioned above.

Note:

1. When replacing batteries, do not use old batteries or a different type battery. This may cause the remote controller to malfunction.
2. If you do not use the remote controller for several weeks remove the batteries. Otherwise battery leakage may damage the remote controller.
3. The average battery life under normal use is about 6 months.
4. Replace the batteries when there is no answering beep from the indoor unit or if the Transmission Indicator light fails to appear.

Automatic Operation

- When the Air Conditioner is ready for use, switch on the power and the OPERATION indicator lamp on the display panel of the indoor unit starts flashing.
 1. Use the MODE select button to select AUTO.
 2. Push the TEMP button to set the desired room temperature. The most comfortable temperature settings are between 21°C to 28°C.
 3. Push the ON/OFF button to start the air conditioner. The OPERATION lamp on the display panel of the indoor

unit lights. The operating mode of AUTO FAN SPEED is automatically set and there are no indicators shown on the display panel of the remote controller.

4. Push the ON/OFF button again to stop the unit.

Notes:

1. In the AUTO mode, the air conditioner can logically choose the mode of COOL, FAN, HEAT and DRY by sensing the difference between the actual ambient room temperature and the set temperature on the remote controller..
2. If the AUTO mode is not comfortable for you , the desired mode can be selected manually.

COOL, HEAT, and FAN ONLY Operation

- If the AUTO mode is not comfortable, you may manually override the settings by using COOL, DRY, HEAT(HEAT PUMP units only), or FAN ONLY modes.
- Push the TEMP button to set the desired room temperature. When in COOLING mode, the most comfortable settings are 21°C or above. When in HEATING mode, the most comfortable settings are 28°C or below.
- Push the FAN SPEED to select the FAN mode of AUTO, HIGH, MED or LOW.
- Push the ON/OFF button. The operation lamp lights and the air conditioner starts to run according to your settings.
- Push the ON/OFF button again to stop.

Note:

The FAN ONLY mode cannot be used to control the temperature. While in this mode, only steps 1, 3 and 4 may be performed.

Dry Operation

1. Push the MODE button to select DRY.
2. Push the TEMP button to set the desired temperature from 21°C to 28°C.
3. Push the ON/OFF button. The operation lamp lights and the air conditioner starts to run in the DRY mode. 4. Push the ON/OFF button again to stop the unit.

Note:

Due to the difference of the set temperature of the unit and the actual indoor temperature, the Air Conditioner when in DRY mode will automatically operate many times without running the COOL and FAN mode.

Time Operation

PUSH TIMER button to set the on and off times of the unit.

1. To set the STARTING time.

- 1) Please push the CANCEL button to cancel any former settings.
- 2) Push the TIMER button. The remote controller will show the TIMER and the signal "h" is shown on the display panel. The control is now ready to reset the TIMER ON to start the operation.
- 3) Push the TEMP button (▼ or ▲) to set desired unit START time .
- 4) After setting the TIMER there will be a one-half second delay before the remote controller transmits the signal to the Air Conditioner. Then, after approximately another 2 seconds, the set temperature will re-appear on the digital display.

2. To set the STOPPING time.

- 1) Please press the CANCEL button to cancel any former settings.
- 2) Push the TIMER button and the remote controller will show the last set time for the START operation and the signal "h" will be shown on the display panel. You are now ready to re-adjust the TIMER OFF to stop the operation.
- 3) Push the TEMP button to cancel the TIMER ON setting. The digital area will show "00".
- 4) Push the TIMER button and the remote controller will show the last set time for the STOP operation and the signal "h" will be shown on the display panel. You are now ready to reset the time of the STOP operation.
- 5) Push the TEMP button (▼ or ▲) to set the time you want to stop the operation.
- 6) After setting the TIMER there will be a one-half second delay before the remote controller transmits the signals to the Air Conditioner. Then after approximately another 2 seconds, the set temperature will re-appear on the

digital display.

3. Set the STARTING & STOPPING time

- 1) Please press the CANCEL button to cancel any former settings.
- 2) Push the TIMER button and the remote controller will show the last setting time for START operation and the signal "h" will be shown on the display panel. You are now ready to readjust the TIMER ON to start the operation.
- 3) Push the TEMP button (▼ or ▲) to set the time you want to start the operation.
- 4) Push the TIMER button and the remote controller will show the last set time for STOP operation and the signal "h" will be shown on the display panel. You are now ready to reset the time of the STOP operation.
- 5) Push the TEMP button (▼ or ▲) to set the time you want to stop the operation.
- 6) After setting the TIMER there will be a one-half second delay before the remote controller transmits the signal to the Air Conditioner. Then, after approximately another 2 seconds ,the set temperature will re-appear on the digital display.

Notes:

1. Please reset the TIMER after cancelling the former time settings.
2. The setting time is relative time. That is the time set is based on the delay of the current time.

14.2 Optional Controller

14.2.1 Wired Controller KJR-10B



■ Name and Function of LCD display on the controller

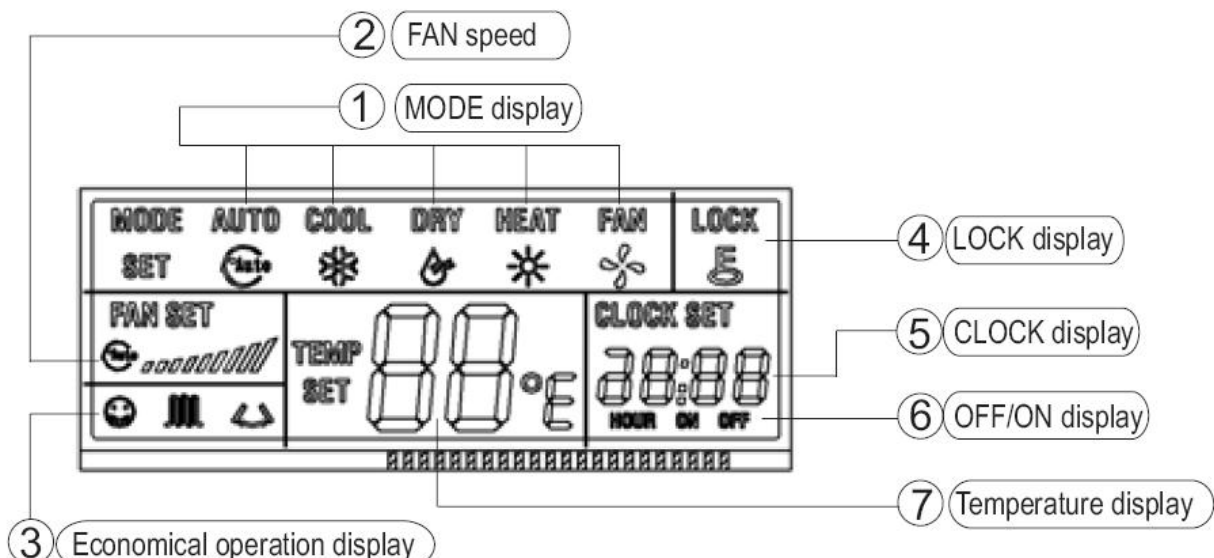

1. Mode select button (MODE)
Press MODE button to select "COOL", "DRY", "HEAT", or "FAN ONLY" mode.(HEAT is invalid for COOL ONLY

wire controller.)

2. Fan speed button (FAN SPEED)

Press FAN SPEED to select fan speed from "AUTO", "LOW", "MED", and "HIGH". NOTE: some air conditioners have no MED fan speed, and then the MED is regarded as HIGH.

3. Economical operation displays

Press ECONOMICAL to display economical operation, if press ECONOMICAL again then the display disappears

4. Lock display

Press LOCK to display the icon of LOCK. Press the button again then the icon of LOCK disappears. In the mode of LOCK, all the buttons are invalid except for LOCK button.

5. CLOCK display

Usually display the clock set currently. Press the button CLOCK for 4 seconds, the HOUR part will flash, press button ▲ and ▼ to adjust HOUR. Presses the button CLOCK again, the minute part flash, press button ▲ or ▼ to adjust MINUTE. After clock set or clock operation, it must press CONFIRM to complete the set.

6. TIMER ON/OFF display

Display ON at the state of TIMER ON adjustment or after only set the TIMER ON; Display OFF at the state of TIMER OFF adjustment or after only set the TIMER OFF; Display ON/OFF if simultaneously set the mode of TIMER ON and TIMER OFF.

7. Temperature display area

Usually display the set temperature. Press the buttons of ▲ and ▼ to set temperature, at the mode of FAN, there is no figure display in the area.

■ Name and Functions of buttons on the controller

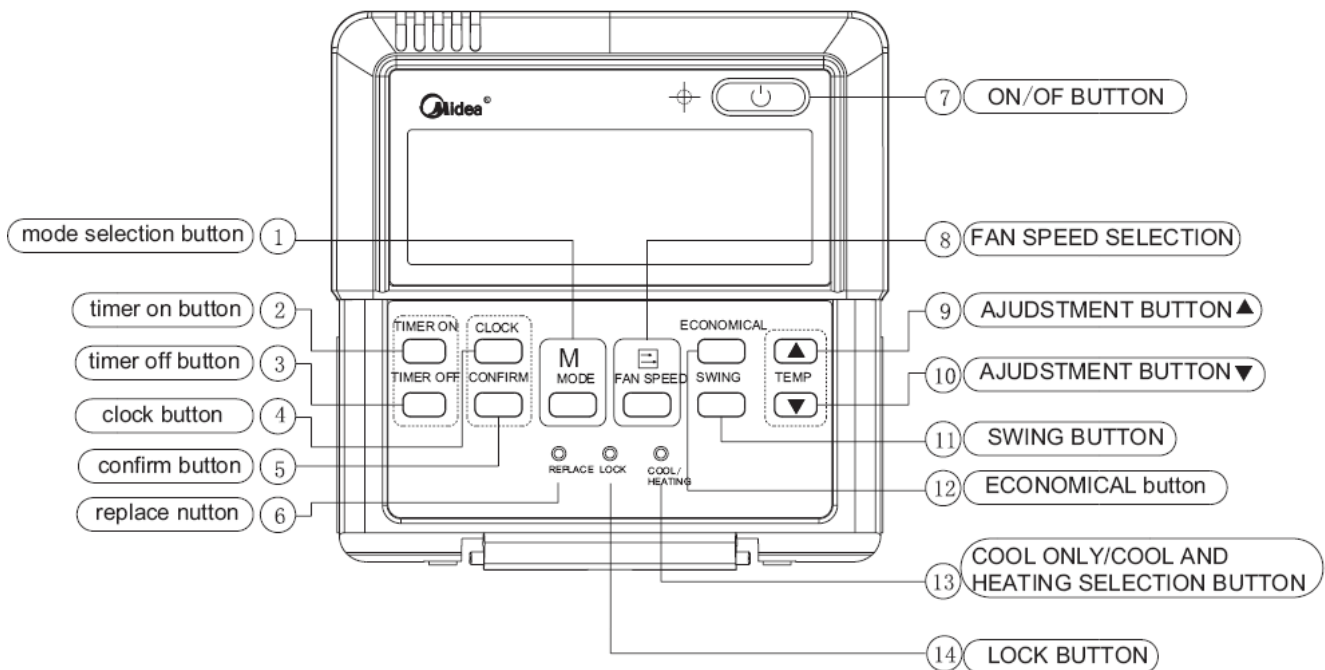

1. Mode selection button

It is used to select mode, push the button one time, then the operation modes will change in turn as follows:

AUTO → COOLING → DEHUMIDIFY → HEATING → FAN

Note: no heating mode if wire controller is set as the cool only.

2. Timer on button

Push the button to set TIMER ON, each time you push the button the time moves forward by 0.5 hours. When the set time is over 10 hours, each time you push the button the time moves forward by 1 hour. If want to cancel the TIMER ON, then adjust the time of TIMER ON as 0.0.

3. Timer off button

Push the button to set TIMER OFF, each time you push the button the time moves forward by 0.5 hours. When the set time is over 10 hours, each time you push the button the time moves forward by 1 hour. If want to cancel

the TIMER OFF, then adjust the time of TIMER OFF as 0.0.

4. CLOCK button

Normally display the clock set currently (display 12:00 for the first electrifying or resetting). When push the button for 4 seconds, the hour part on the clock display flashes every 0.5 seconds, then push button and to adjust hour; push the button CLOCK again, the minute part flashes every 0.5 seconds, then push and button to adjust minute. When set clock or alter clock setting, must push the confirm button to complete the setting.

5. Ok button

The button is used at the state of CLOCK adjustment. After select the time, push the button to confirm then exit, the current clock will display.

6. Reset button (hidden)

Use a small stick with a diameter of 1mm to push the RESET button to cancel the current settings and get into the condition of resetting.

7. ON/OFF button

Push the button at the condition of OFF, the OPERATION lamp lights, and the wire controller enters into ON operation, simultaneously sends the information of operation mode set currently, temperature, fan speed, timer etc. Push the button at the condition of ON, the OPERATION lamp extinguishes simultaneously sends the OFF. If having set TIMER ON or TIMER OFF, the wire controller will cancel these settings before entering into OFF, close the concern indicator, and then send the OFF information.

8. Fan speed selection button (FAN SPEED)

Select any one fan speed from "AUTO", "LOW", "MED", and "HIGH". Each time push the button, the fan speed will change in turn as follow:

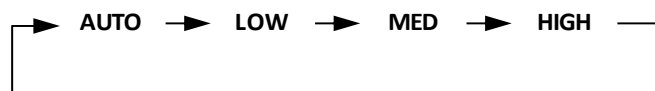

9. Adjust button ▲

Set indoor temperature up. If press and hold on, it will increase at 1 degree per 0.5 second.

10. Adjust button ▼

Set indoor temperature down. If press and hold on, it will decrease at 1degree per 0.5 second.

11. Swing button

Push this button for the first time when operation, it will start the swing function. Push the button for the second time, cancel the swing function. (The function is available matched with the concerned unit)

12. Economical button

Push the button to set the economical operation mode for air conditioner, push again then cancel the mode. The operation mode is suitable for sleeping time.

13. Cool Only/Cooling and Heating selection button (hidden)

Use a small stick with a diameter of 1mm to push the button to switch modes. For COOLING ONLY type, it will be no heating mode when pressing MODE. The uniform mode is COOLING and HEATING at the factory.

14. Lock button (hidden)

Use a small stick with the diameter of 1mm to push the LOCK button to lock the current setting, push the button again then cancel the setting.

■ Installation

Wiring Principle Sketch:

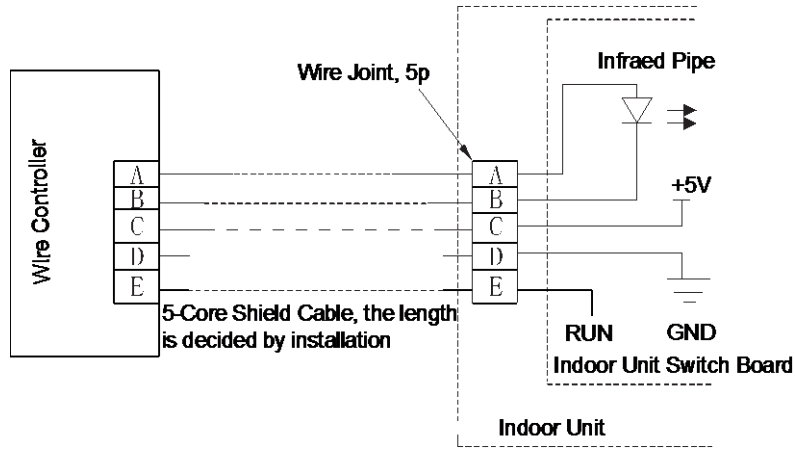

Installation description:

When the air conditioner needs the constant frequency wire Controller, be sure adding a Wire Joint with 5 terminal named A, B, C, D, E in indoor unit, and fixing an infrared emitter whose anode and cathode connecting with A and B near the receiver in the Indoor Unit Switch Board, then connecting the terminal +5V, GND, Run in the Switch Board to C, D, E respectively.

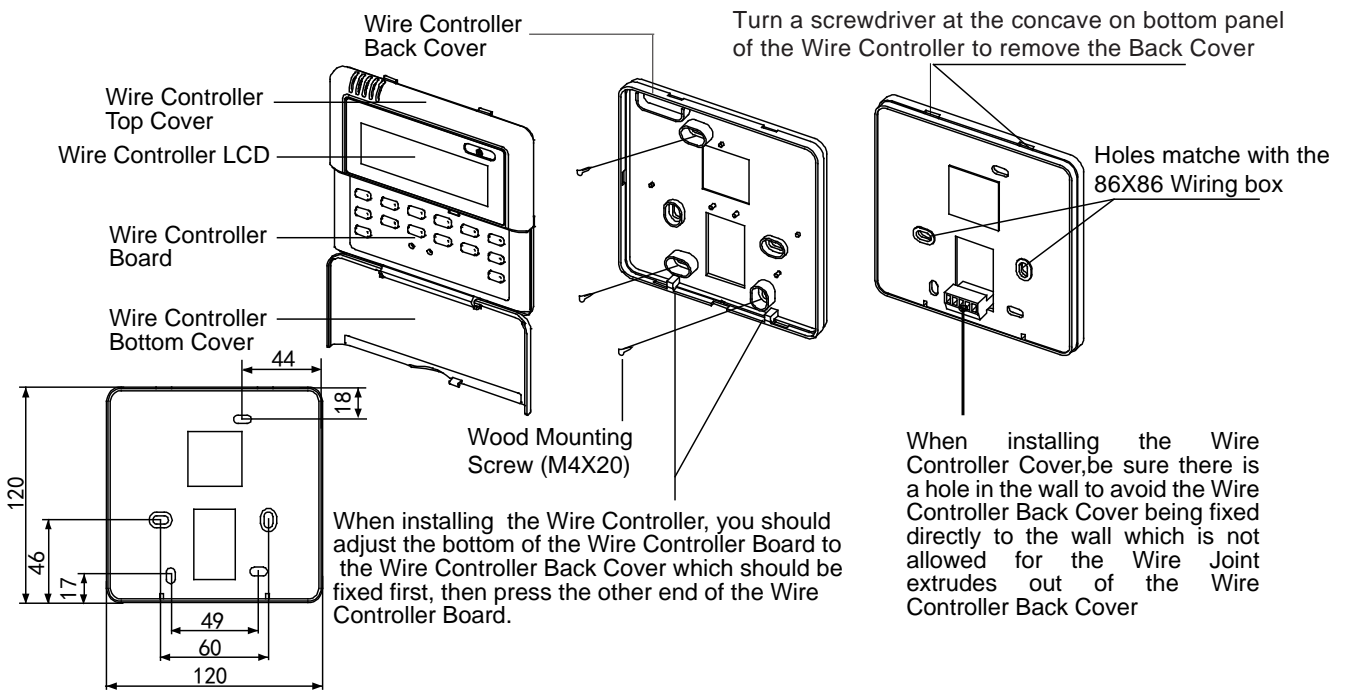

Notes:

- Never turn screws too tightly, or else the cover would be dented or the Liquid Crystal breaks.
- Please leave enough long cable for maintenance of the Wire Controller Board.

14.2.2 Wired Controller: KJR-12B



■ Name and Function of LCD display on the controller

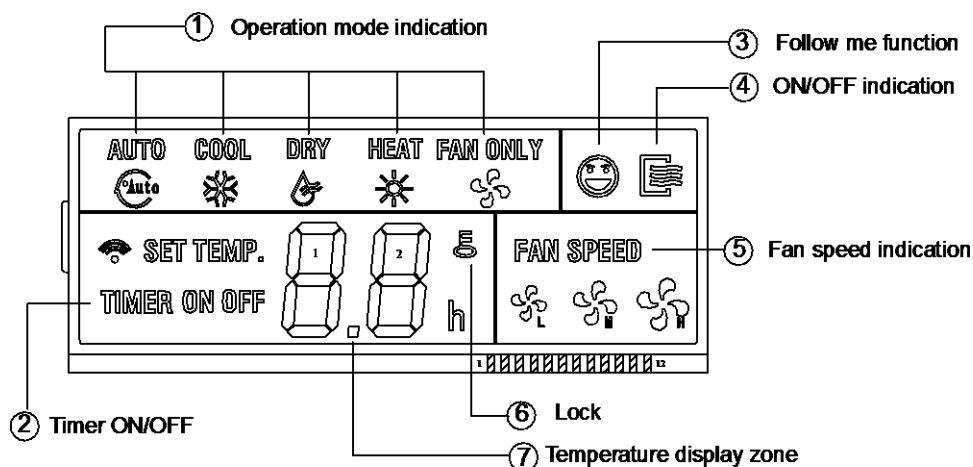

1. Operation mode indication

When press "MODE" button, the following mode can be selected in circle.

Auto → Cool → Dry → Heat → Fan only → Auto

For cooling only model, heat mode is skipped.

2. Timer

When adjust setting on time or only on time is set, the "ON" is lighted.

When adjust setting off time or only off time is set, the "OFF" is lighted. If on and off timer are both set, the "ON" and "OFF" are both lighted.

3. Follow me function

There is a temperature sensor inside the wire controller, after setting temperature, it will compare the two temperatures, and the space of wire controller will be the same as setting temperature. It is available under cooling, heating, auto mode.

4. ON/OFF indication

When it is on, the icon display, otherwise it is extinguished.

5. Fan speed indication

There are four fan modes: low, middle, high, and auto. For some models, no middle fan then the middle fan is seen as high speed.

6. Lock

When the "LOCK" button is pressed, the icon appear and other buttons is unable, press again, the icon disappear.

7. Temperature display zone

Generally it displays setting temperature, it can be adjusted by press temperature button ▲ and ▼. But no display in fan mode.

■ Name and functions of buttons on the controller

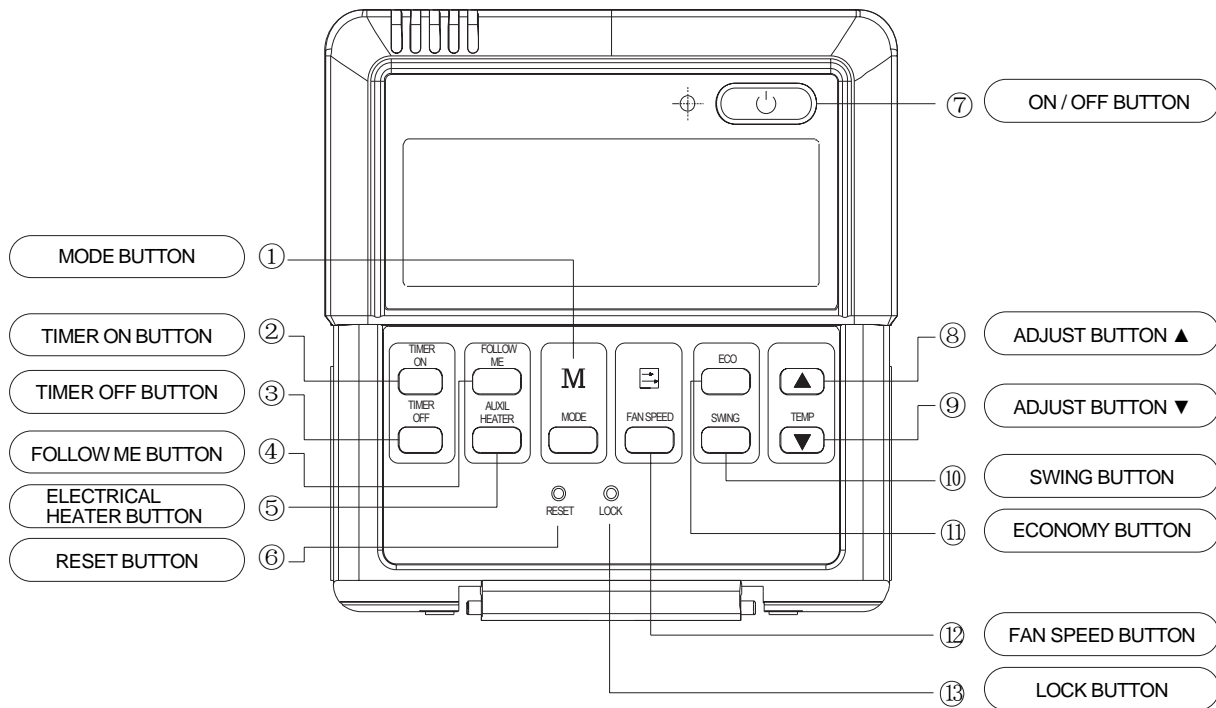

1. Mode button

When press this button, the operation mode change as the following sequence:

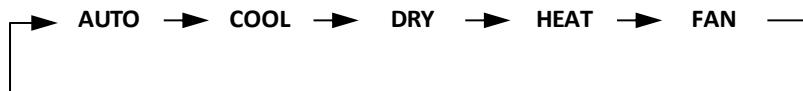

Note: For the cooling only model, the heating mode is skipped.

2. Timer on button

Press this button, timer on function is active. Then every press, the time increase 0.5h, after 10h, 1h increase after each press. If cancel this function, just set it to "0.0".

3. Timer off button

Press this button, timer off function is active. Then every press, the time increase 0.5h, after 10h, 1h increase after each press. If cancel this function, just set it to "0.0".

4. Follow me button

When under cool, heat and auto mode, and press this button, follow me function is active. Press again, this function is ineffective.

5. Electrical heater button

If press this button in heat mode, electrical heater function become ineffective.

6. Reset button(hidden)

Use a 1mm stick to press in the little hole, then the current setting is canceled. The wire controller enters into original state.

7. ON/OFF button

When in off state, press this button, the indicator is on, the wire controller enter into on state, and send setting information to indoor PCB. When in on state, press this button, the indicator is off, and send instruction. If timer on or timer off has been set, it cancel this setting then send instruction to stop the machine.

8. Adjust button ▲

Set indoor temperature up. If press and hold on, it will increase at 1°C (2°F) per 0.5 second.

9. Adjust button ▼

Set indoor temperature down. If press and hold on, it will decrease at 1°C (2°F) per 0.5 second.

10. Swing button

First press "start swing"; second press "stop swing". (Match to some model with swing function).

11. Economy operation button

Press this button, the indoor unit operates in economy mode, press again, exit this mode (it may be ineffective for some models)

12. Fan speed button

Press this button consecutively; the fan speed will circle as follow

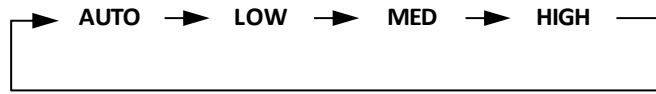

13. Lock button(hidden)

When you push the LOCK button, all current settings are locked in and the wire controller does not accept any operation except that of the LOCK button. Use the lock mode when you want to prevent setting from being changed accidentally or play fully. Push the LOCK button again when you want to cancel the LOCK mode.

■ Installation

Wiring Principle Sketch:

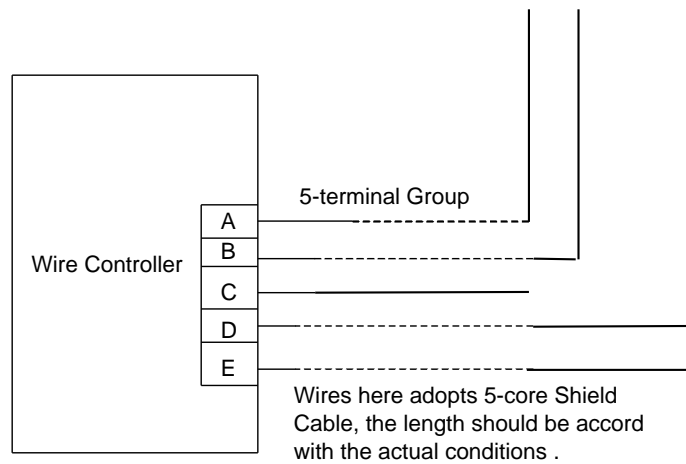

Installation description:

When it is necessary to use this controller, it needs to add a small 5-terminal group and fasten an infrared emitter near to the receiver in the switch board. Connecting the anode and cathode to A, B of the Terminal Group, also connect +5V, GND, RUN of the switch board separately to the C, D, E of the 5-terminal Group.

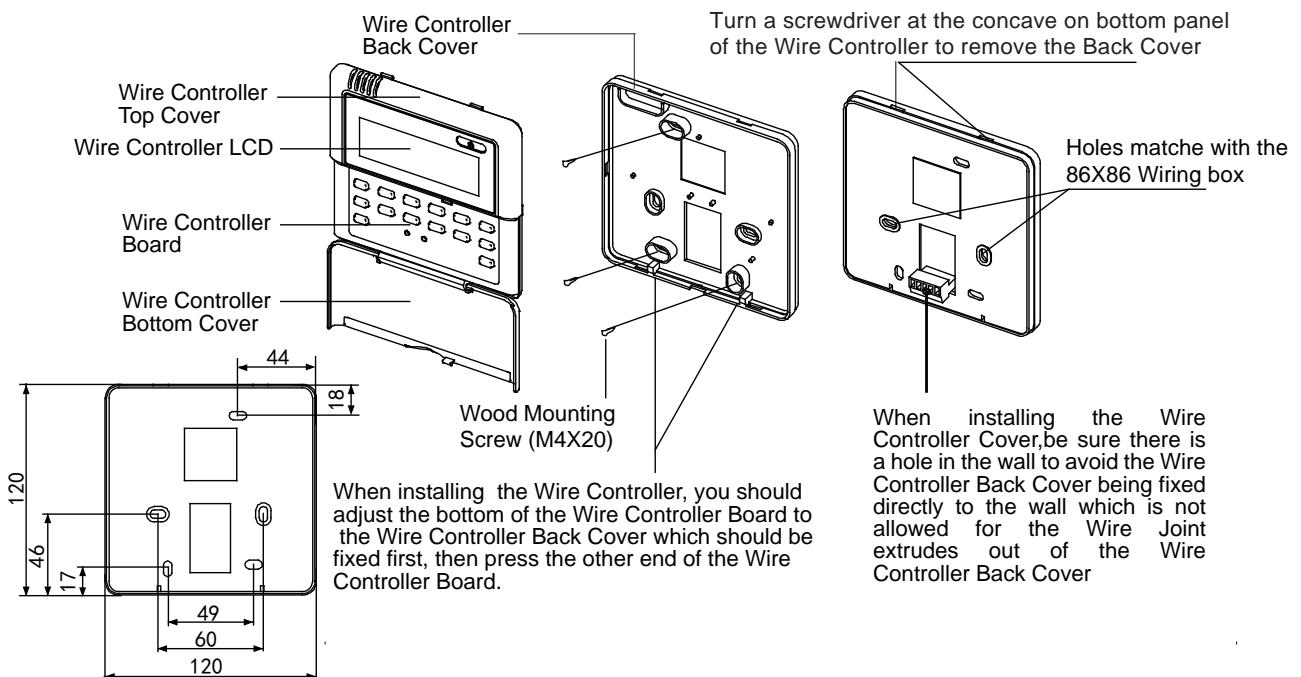

Caution:

The connecting wire should be a little longer as to take away the switch board easily for maintenance

The connecting wire should be a little longer as to take away the controller easily for maintenance.

14.2.3 Central Controller: MD-CCM03

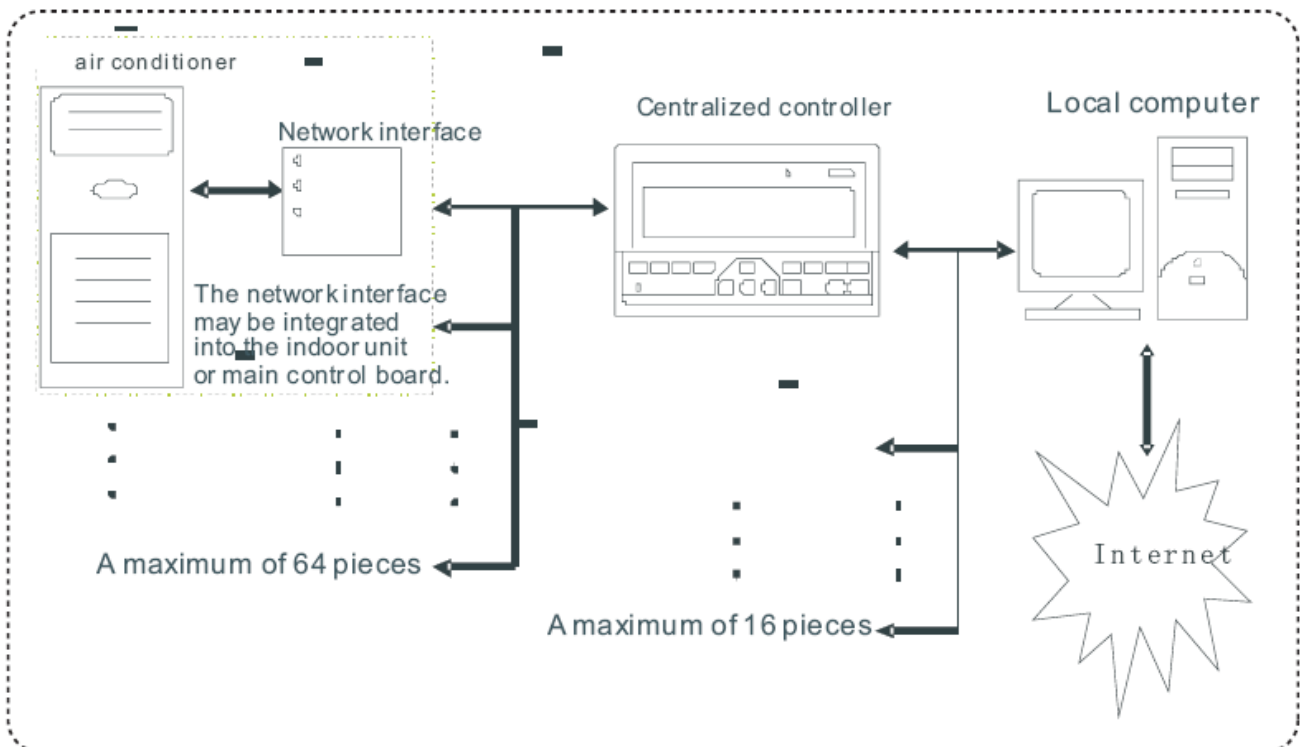

Full display of LCD

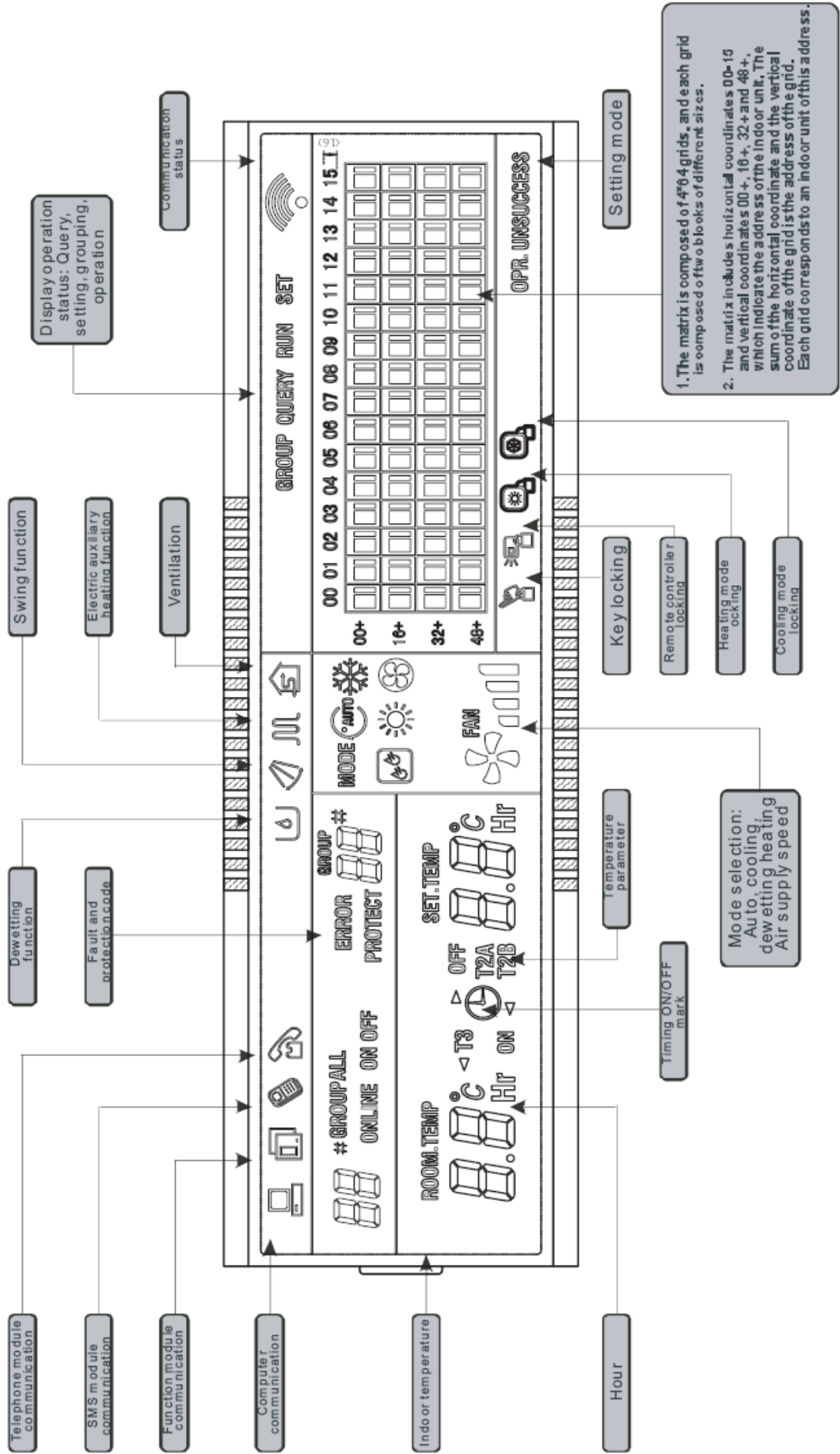

■ Liquid crystal matrix display description



1. The liquid crystal matrix is composed of 4×64 grids, and each grid is composed of two blocks of different sizes (as shown in the above figure).
2. The matrix includes horizontal coordinates 00-15 on the upper side and vertical coordinates 00+, 16+, 32+ and 48+ on the left side, which indicate the address of the indoor unit. The sum of the horizontal coordinate and the vertical coordinate of the grid is the address of the grid. Each grid corresponds to an indoor unit of this address.
3. One grid is composed of two blocks of different sizes. The status

Indication table is as follows:

| | | | | |
|-------------------|---------------|------------|----------------------|----------------|
| Status | Constantly on | Slow blink | | Fast blink |
| Object | | | | |
| Big black block | In-service | Selected | | Out of service |
| Small black block | Power on | | Fault of indoor unit | Power off |

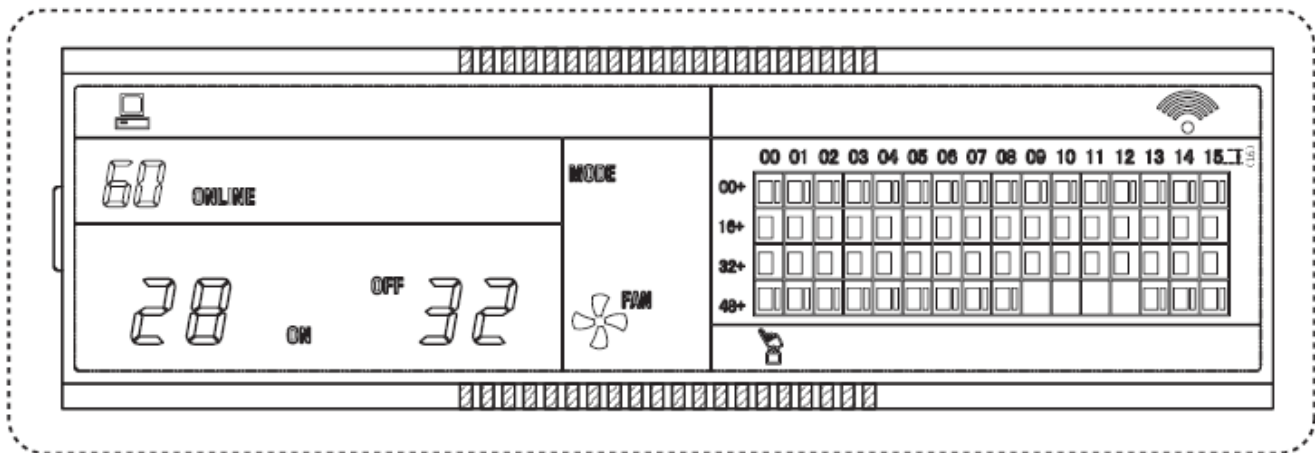

■ LCD display description

1. Description of the standby page
 - 1) The LCD displays the standby page, 60 air conditioners are in service, of which 28 are powered on and 32 off.
 - 2) In the matrix, the big dots of (00, 16+) and (15, 32+) are luminous, and the small dots are not luminous. It indicates the 32 air conditioners with the addresses from 16 to 47 are powered off.
 - 3) In the matrix, the big and small dots of (09, 48+) and (12, 48+) are not luminous. It indicates the four air conditioners with the addresses from 57 to 60 are outside the network.
 - 4) All other big and small dots in the matrix are luminous. It indicates all other air conditioners are in the network and powered on.
 - 5) The address of the air conditioner is sum of the coordinates. For example, the address of (09, 48+) is 09+48=57.
 - 6) The centralized controller keypad is locked, and the centralized controller communicates with the computer normally.

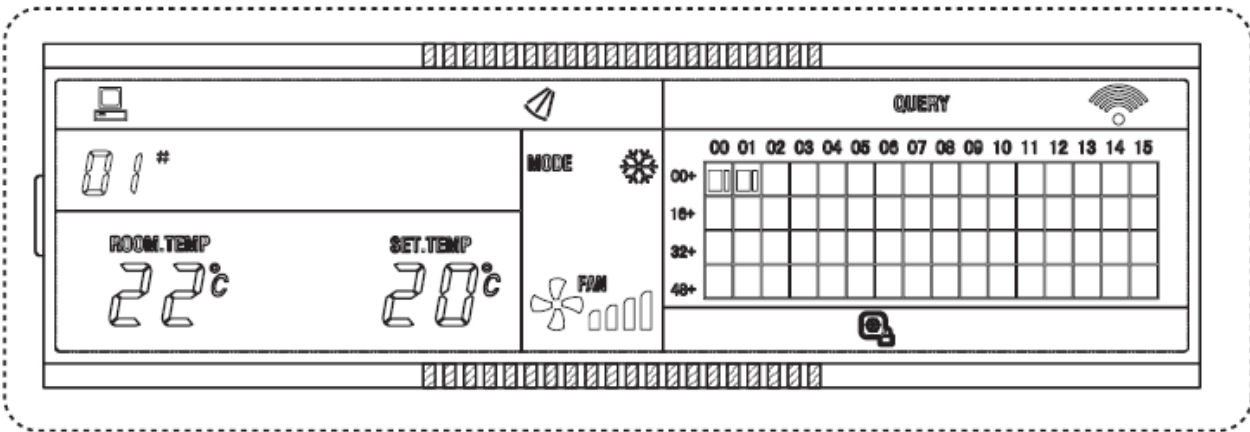

2. Description of the query page

- 1) The LCD displays the query page, and the air conditioner with the address of 08 is being queried. Mode of the air conditioner with the address 01 is: Cooling, strong air, swing on, indoor temperature 22°C, set temperature 20°C, cooling mode “lock”.
- 2) In the matrix, only the big and small black dots at (00, 00+) and (01, 00+) are luminous. It indicates the in-service and power-on status of the air conditioners with the addresses of 00 and 01.
- 3) The centralized controller communicates with the computer normally.

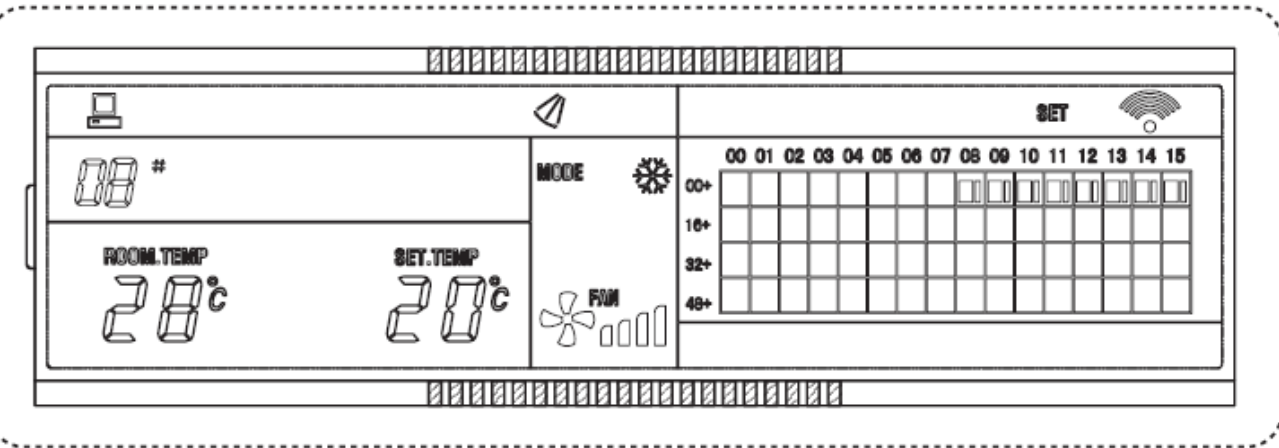

3. Description of the setting page

- 1) The LCD displays the setting page, and queries the air conditioner with the address of 08. The mode of the air conditioner with the address 08 is: Cooling, strong air, swing on, indoor temperature 28°C, set temperature 22°C, cooling.
- 2) In the matrix, only the big black dots from (08, 00+) to (16, 00+) are luminous. It indicates the air conditioners with the addresses from 08 to 16 are in service.
- 3) The centralized controller communicates with the computer normally.

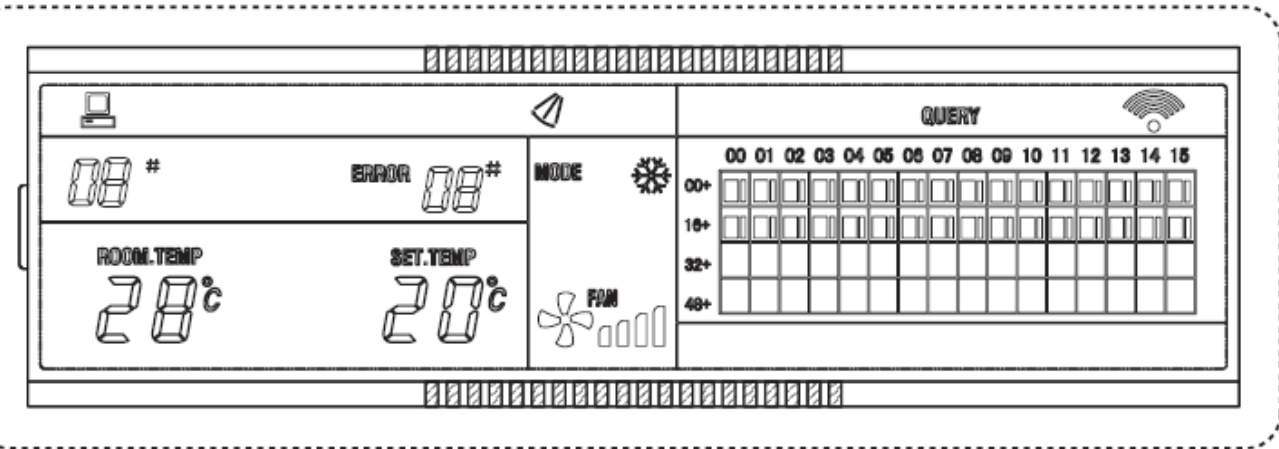

4. Fault page display description

- 1) Query the air conditioner with the address of 08 in the query page. The air conditioner with the address of 08 is faulty, and the fault code is 08. The big black dot below (08, 0+) blinks.
- 2) In the matrix, only the big and small black dots from (00, 00+) to (16, 15+) illuminate. It indicates the in-service status of the air conditioners with the addresses of 00 and 01.
- 3) The centralized controller communicates with the computer normally.