

## DIMENSIONES EXTERIORES

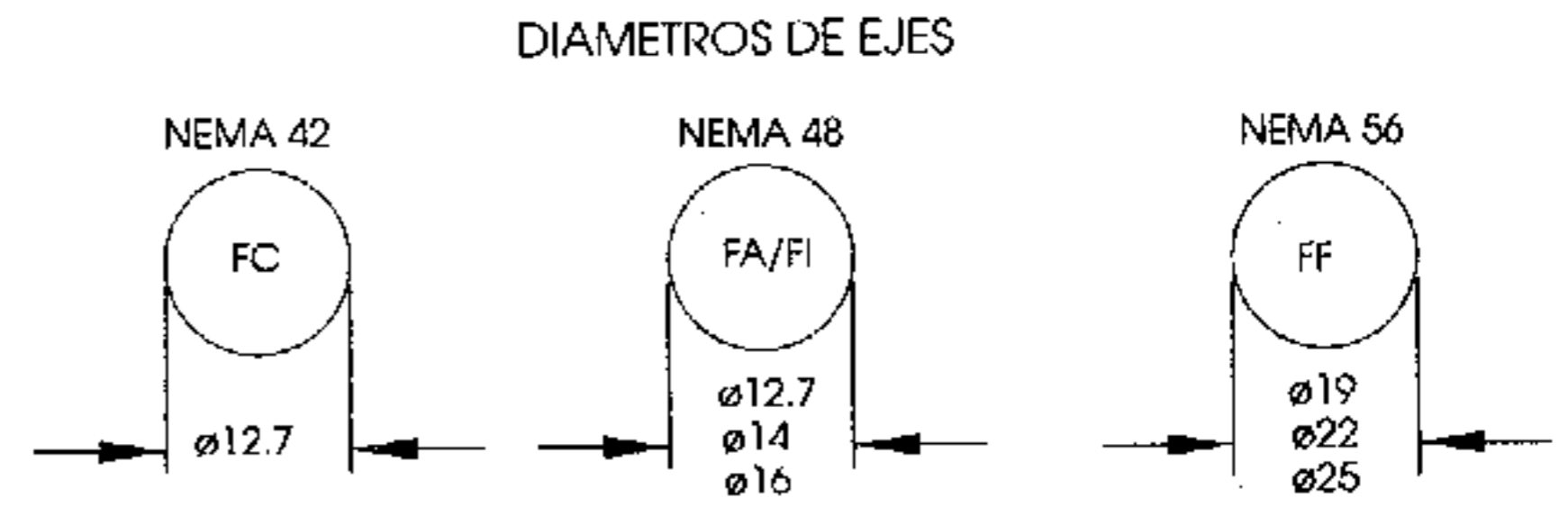

## FORMAS DE MONTAJE

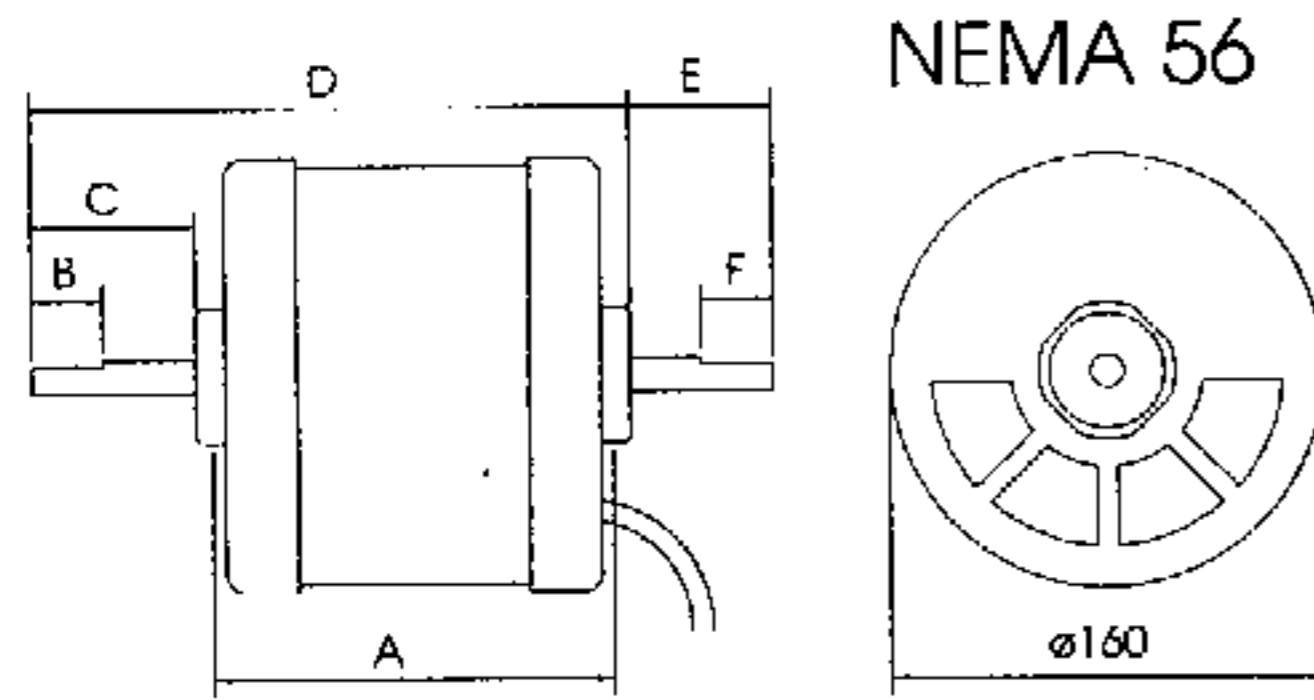
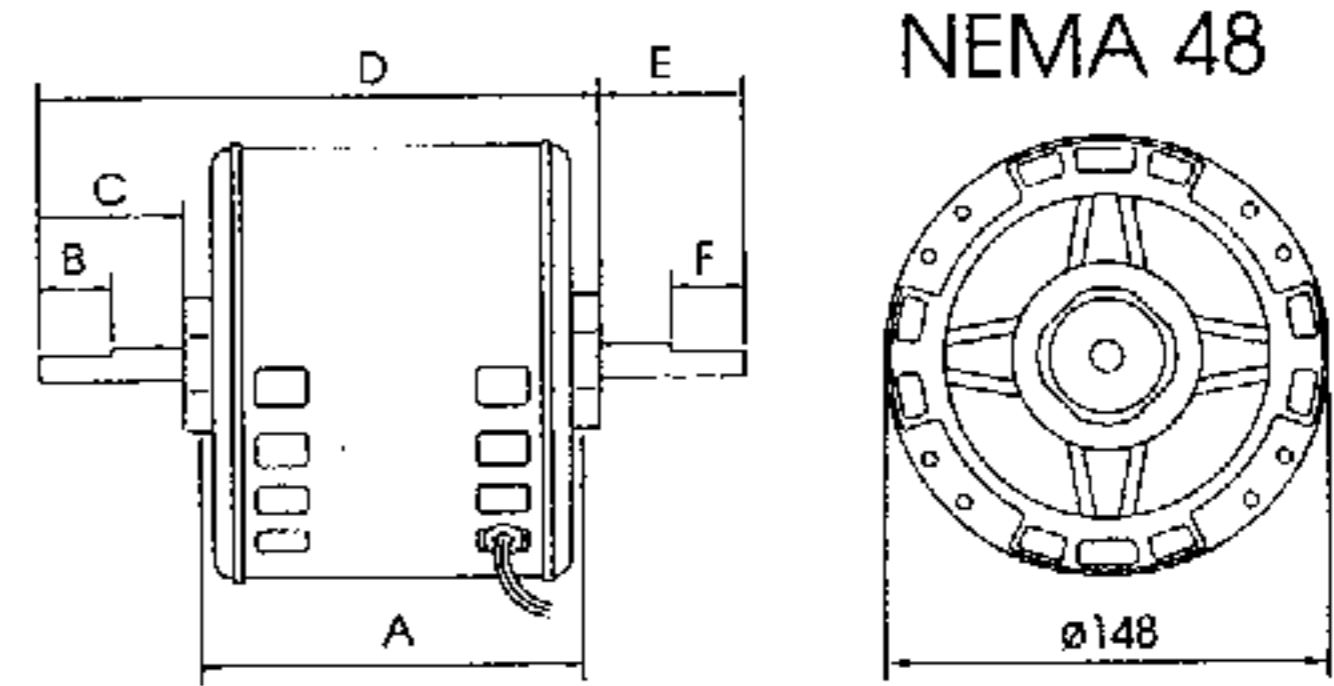
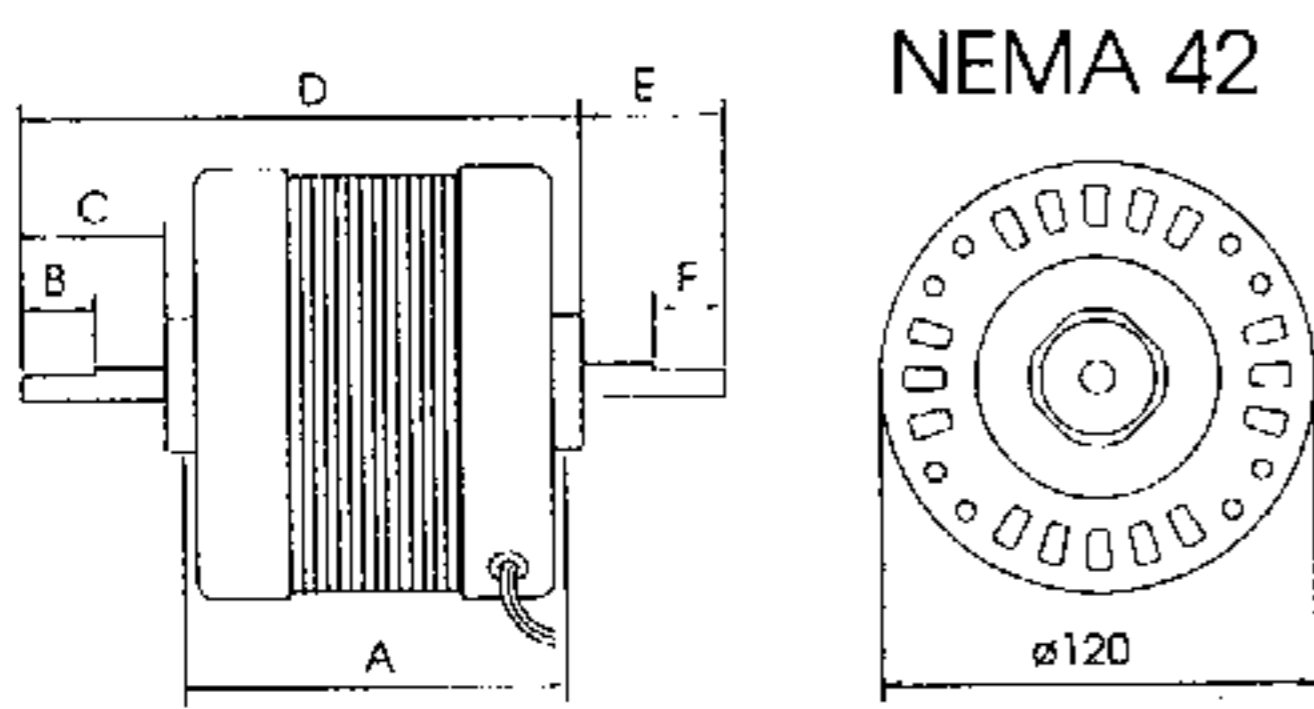
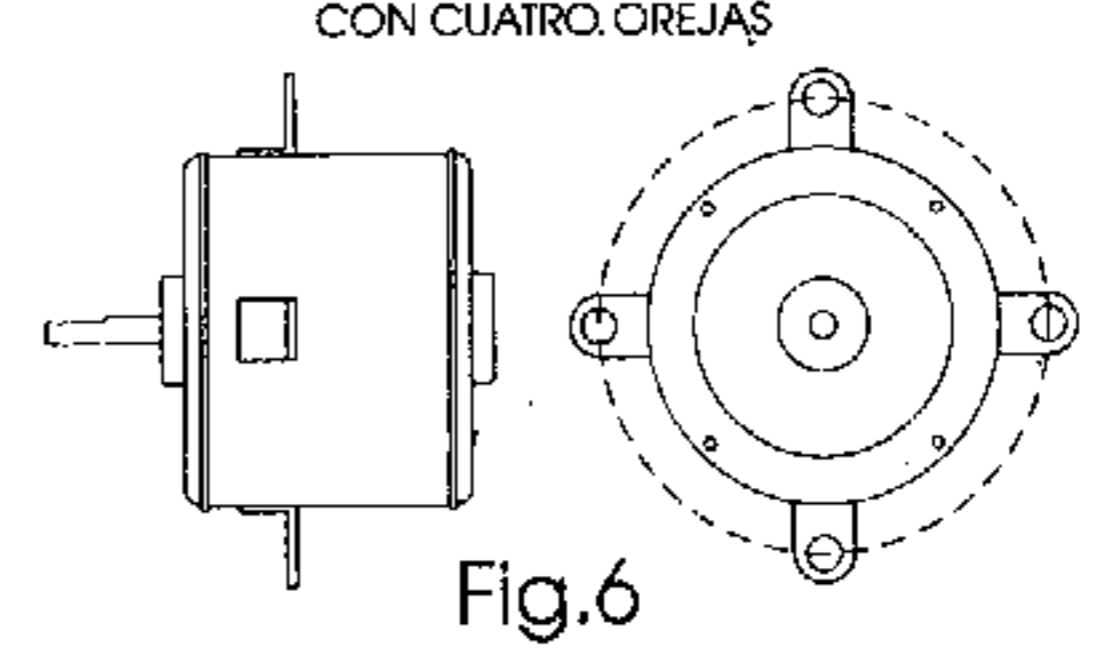
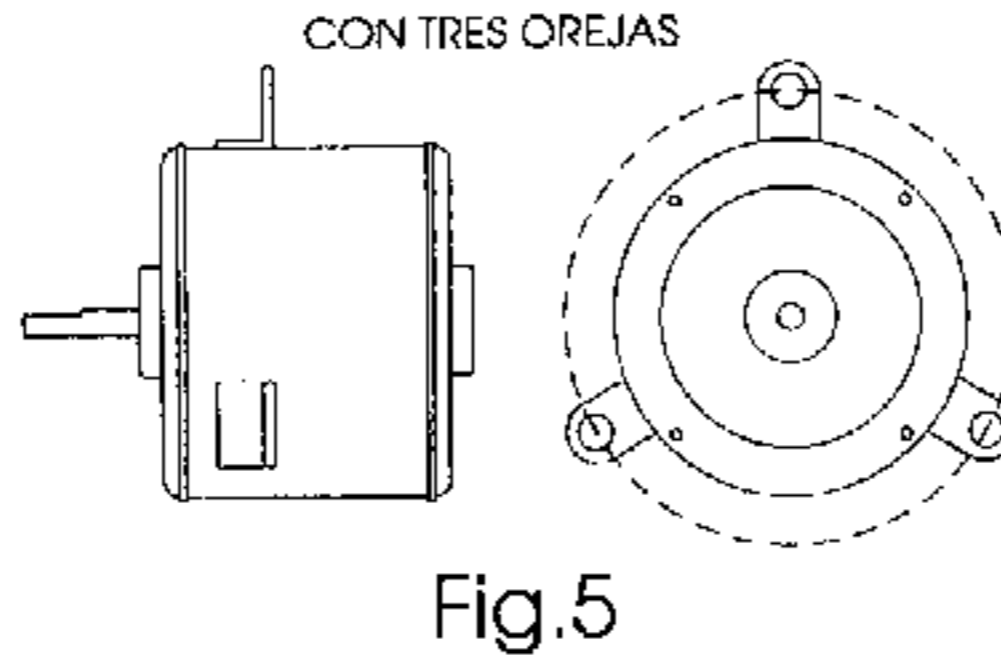
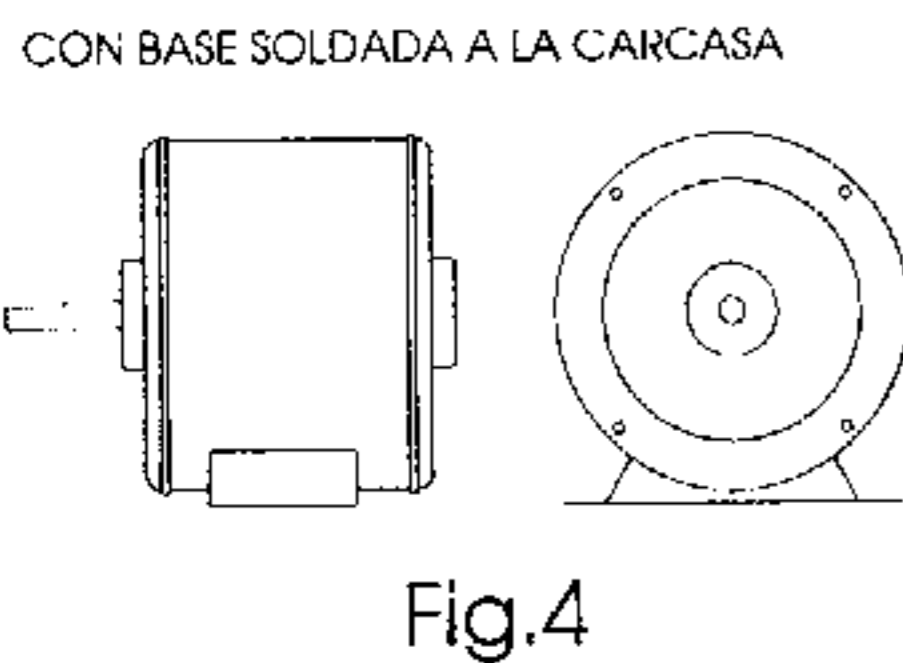
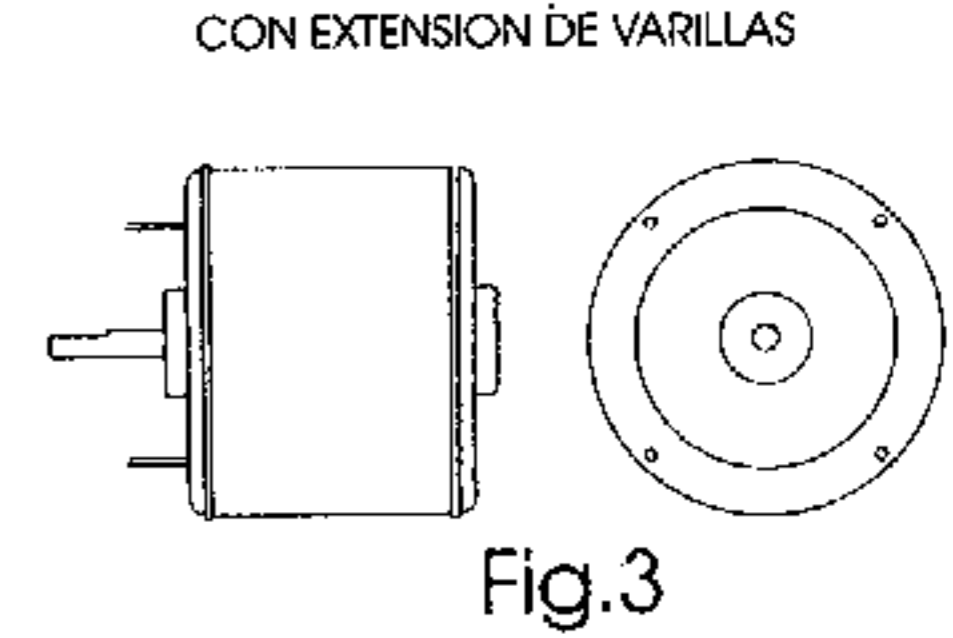
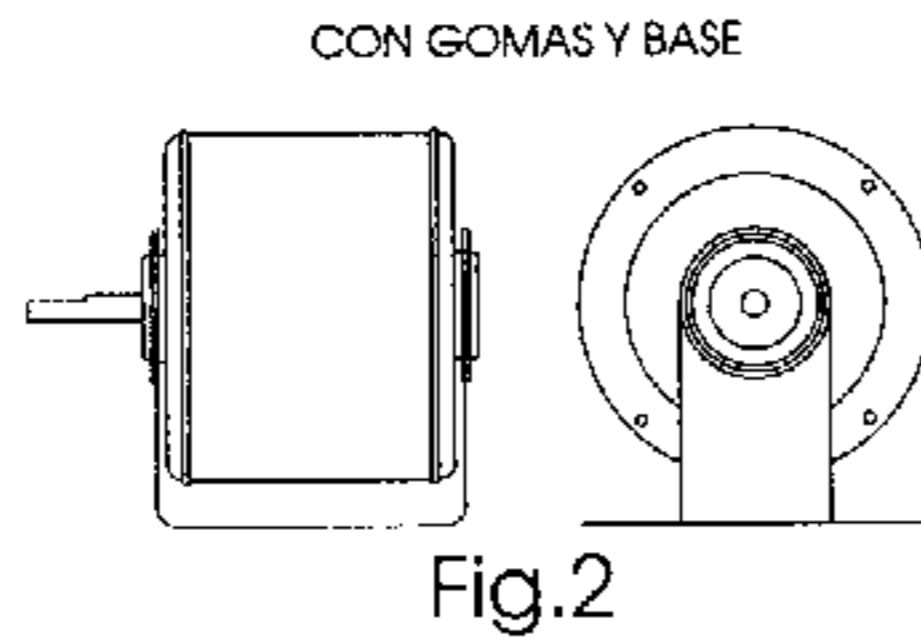
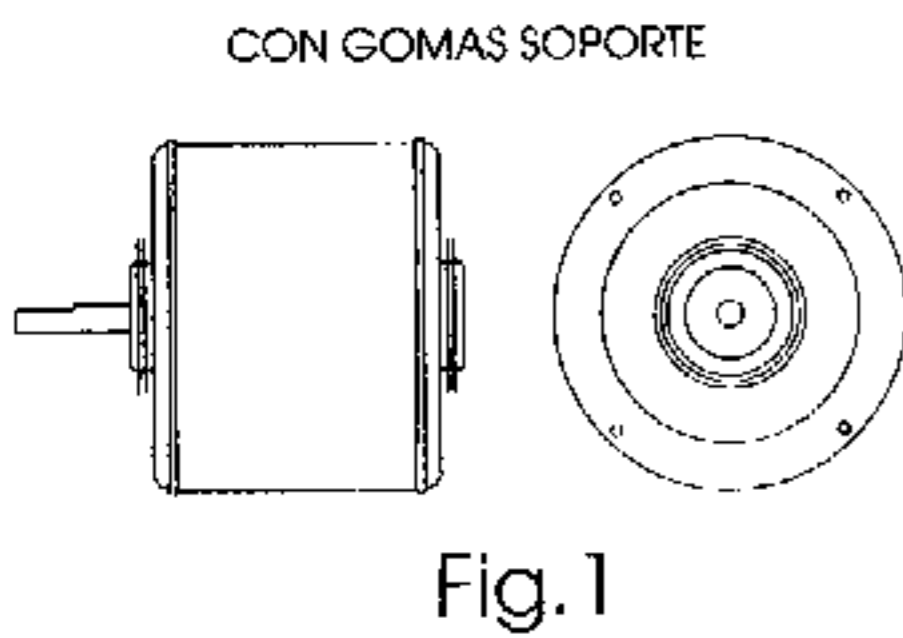

## ESQUEMAS DE CONEXION

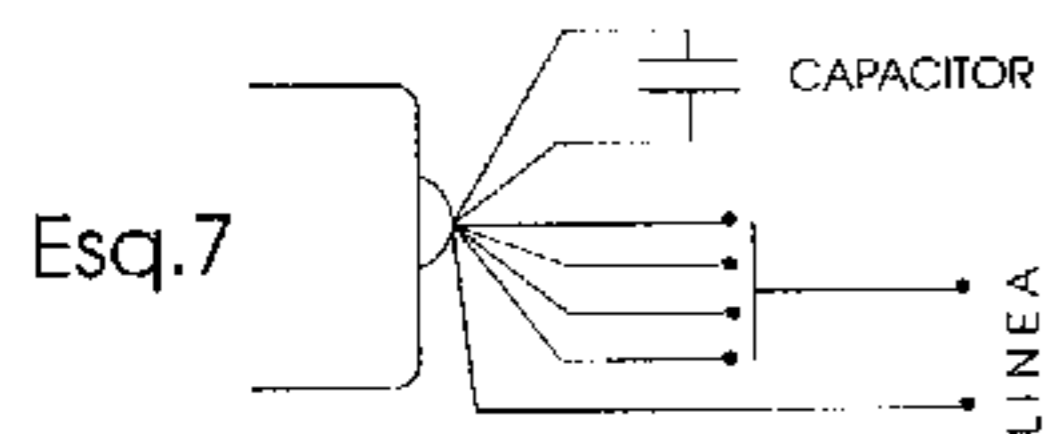
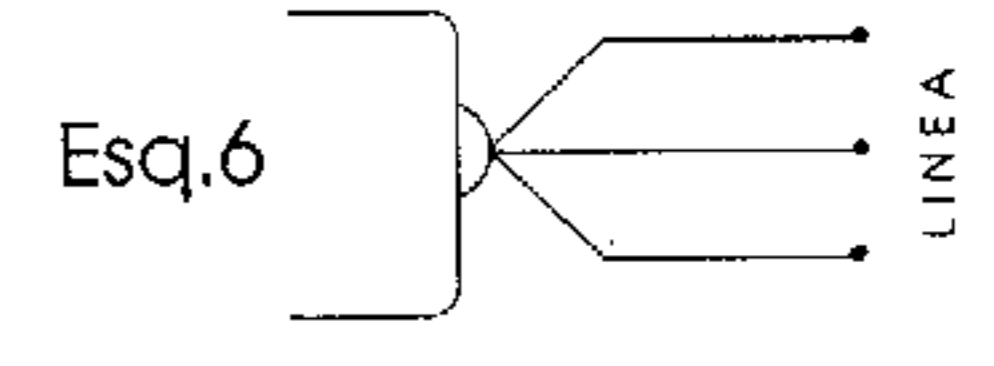
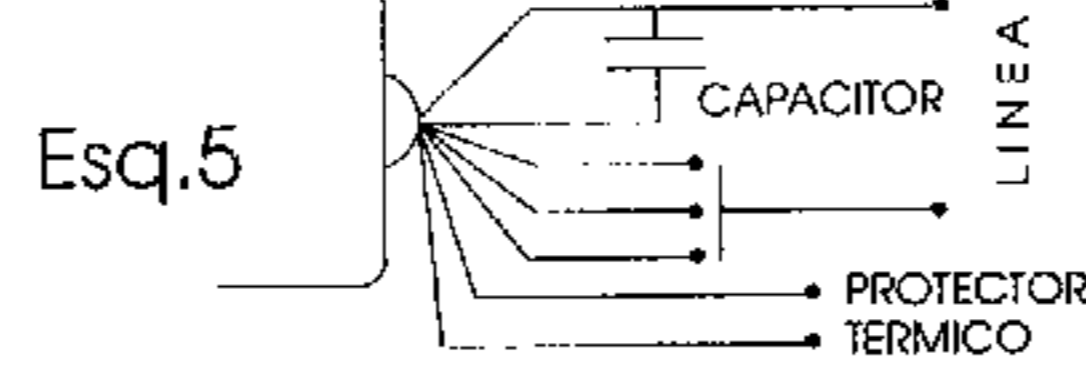
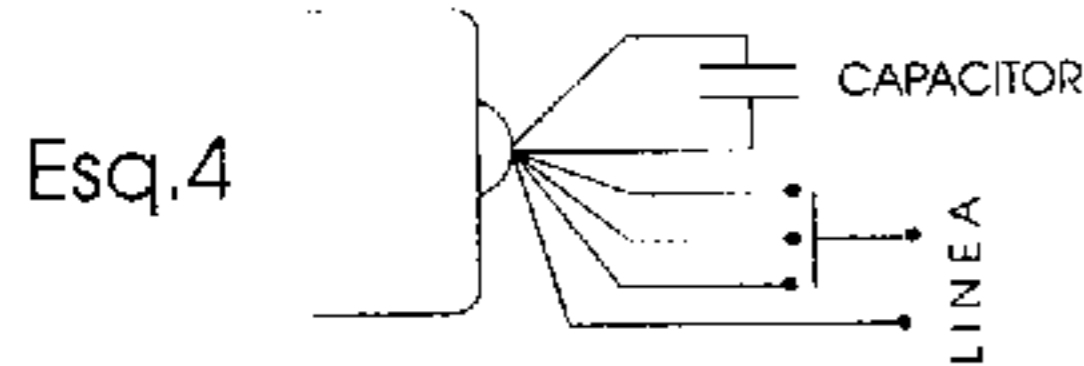
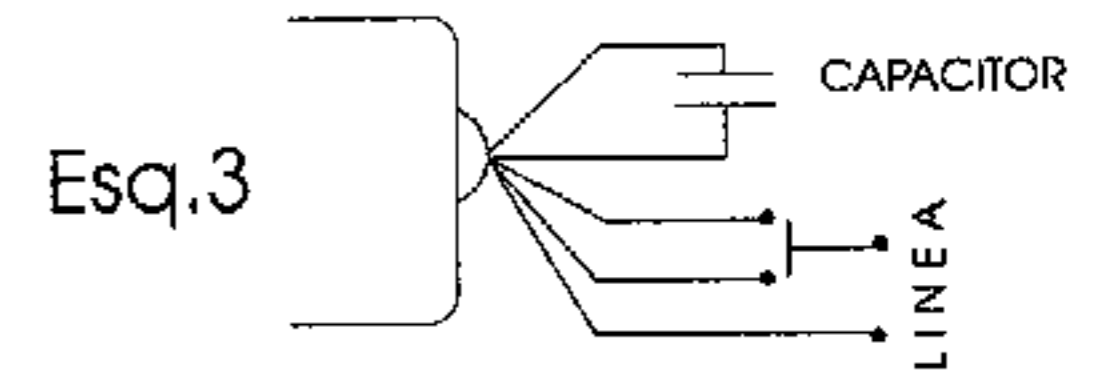
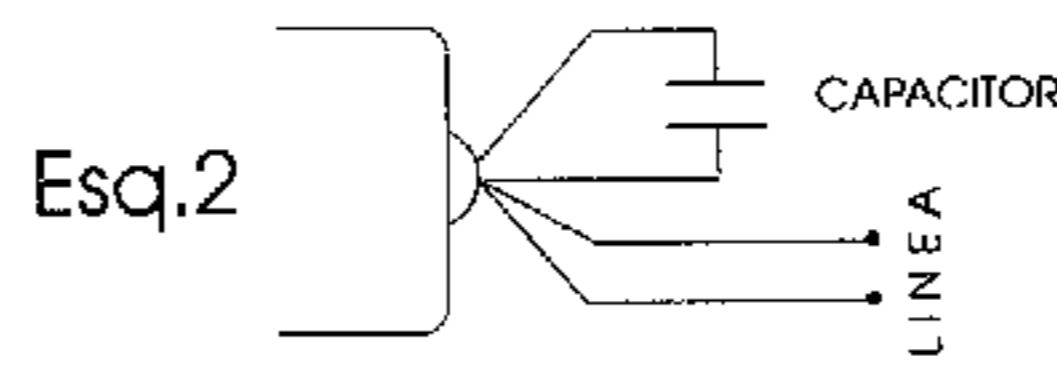
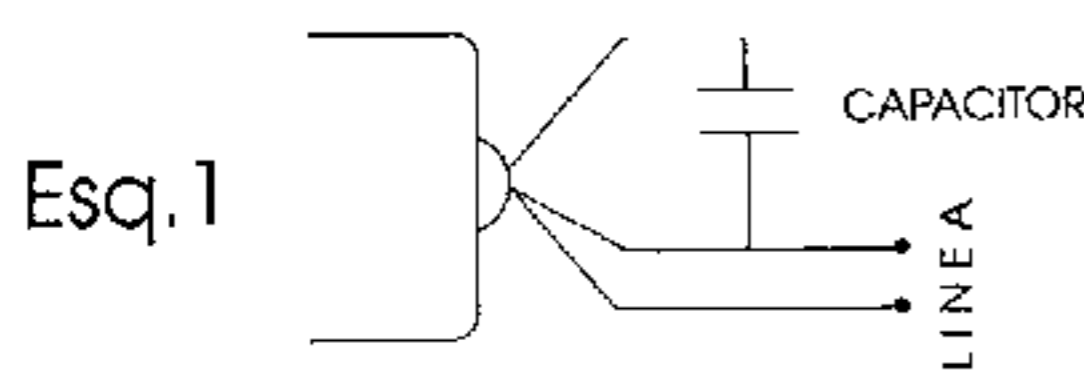

### IMPORTANTE

LOS DATOS ELECTRICOS FUERON OBTENIDOS DE MOTORES INSTALADOS EN EQUIPOS ESPECIFICOS ESTOS PUEDEN VARIAR SEGUN LA CARGA APLICADA DIMENSIONES EXTERNAS Y VALORES ELECTRICOS SUJETOS A MODIFICACION

