

RS332N

3-Heat / 2-Cool
Non-Programmable
Setback Thermostat

with the Industry's Most
Advanced Remote Sensor Bus

for Gas, Electric, & Heat Pump Systems

Robertshaw

www.robertshawclimate.com

TABLE OF CONTENTS

Introduction.....	2
Standard Features.....	2
Button Operations.....	3
Thermostat Locations.....	3
Removing The Thermostat From The Backplate.....	4
Description Of The Dip Switch Functions.....	5
Features And Settings.....	6-7
Cover Lock.....	7
Replacing The Thermostat On The Backplate.....	7
Button Press Combinations.....	8
Keypad Lockout.....	9
Temporary Override.....	9
Setback Input Terminals – Special Functions.....	9
Changing Fahrenheit (°F) To Celsius (°C).....	10
Power Failures.....	10
Remote Sensors (Optional).....	10
Setup Menu.....	10-11
Wiring Diagrams.....	11-20
Specifications.....	21
Sensor Faults.....	21
Description Of Icons.....	22-23
Display.....	23
Warranty.....	23-24

INTRODUCTION

The RS300N family of Non-Programmable Setback Thermostats represents the most advanced solid-state, microcomputer temperature control on the market today. The thermostat incorporates state-of-the-art technology packaged in an extremely low profile designer series case. They are a direct replacement for 300 series and DSL series non-programmable units. The Ultra-Touch push-buttons are combined with an easy-to-read, blue backlit full function liquid crystal display to provide the ultimate in user friendly operation of the heating and air conditioning, including gas, electric, oil and heat pump systems.

STANDARD FEATURES

- No batteries required – always remembers setpoints
 - Integrated electronic heat anticipation and cooling droop with built-in short cycle equipment protection
 - Intelligent Fuzzy Logic staging for efficient operation of equipment, including auxiliary heat
 - Tamper proof electronic keyboard lockout with programmable override ranges and time
 - Automatic, Manual and Recirculation Fan operation
 - Adjustable Fan Purge after Heating or Cooling Call
 - Automatic Heat/Cool Changeover, Cooling Only, or Heating Only Mode Control
 - Adjustable Deadband between Heat and Cool Setpoint in Auto Changeover
 - Dual Heating and Cooling Setpoints for Day (Occupied) and Night (Unoccupied) operation
 - Adjustable Min/Max Setpoints for Heating and Cooling
 - Keypad Lockout with restricted +/-3°F(1°C) or +/-5°F(2°C) setpoint adjustment and 0min to 24Hr override timer with automatic return
 - Selectable Fahrenheit or Celsius temperature display
 - Adjustable Backlight Brightness
 - Integrated Installer Setup Menu
 - Up to 10 Remote Sensors can be added:
- Surface Mount:
- 10-528 or RS300-528 (indoor) (up to 6)
 - 10-529 or RS300-529 (outdoor)
- Single Gang Box Mount :
- RS300-530 (Aux 1 – Aux 3)
 - AVAILABLE PROBES FOR RS300-530
 - RS300-531 (6" stainless steel w/box)
 - RS300-532 (direct in-pipe water)
- Occupancy Sensor Inputs (use RS-OSC or RS-OSW)
 - Two (2) Digital Inputs with LED Indicators

BUTTON OPERATION

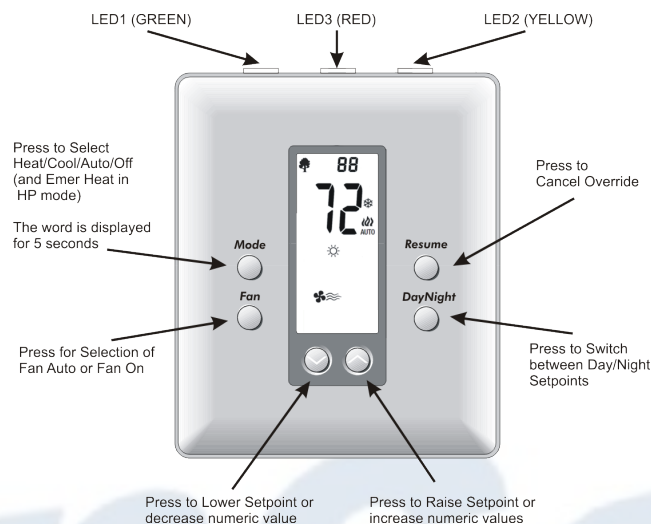

THERMOSTAT LOCATION

To ensure proper operation, the thermostat should be mounted on an inside wall in a frequently occupied area of the space. In addition, its position must be at least 18" (46 cm) from any outside wall, and approximately 5', (1.5 m) above the floor in a location with freely circulating air of an average temperature.

Be sure to avoid the following locations:

- Behind doors or in corners where freely circulating air is unavailable
- Where direct sunlight or radiant heat from appliances might affect control operation
- On an outside wall
- Adjacent to, or in line with, conditioned air discharge grilles, stairwells or outside doors
- Where its operation may be affected by steam or water pipes or warm air stacks in an adjacent partition, or by any unheated / uncooled area behind the thermostat
- Where its operation may be affected by lighting dimmers next to it
- Where its operation will be affected by the supply air of an adjacent unit
- Near sources of electrical interference such as arcing relay contact

REMOVING THE THERMOSTAT FROM THE BACKPLATE

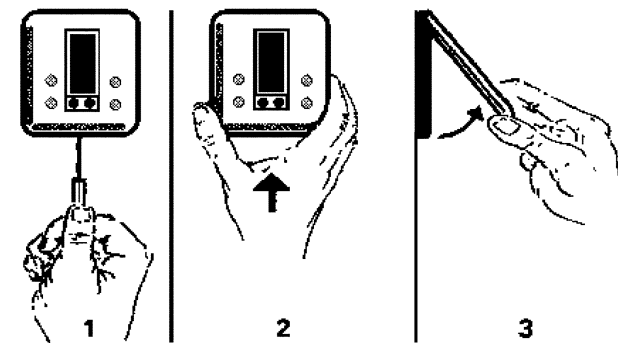

1. Insert a flat blade screwdriver or coin 1/8" into the slot located in the bottom center of the thermostat case and twist 1/4 turn. When you feel or hear a click, grasp the case from the bottom two corners and separate from the backplate as shown in the diagram at the left. Some models require more force than others when separating due to the number of terminals used.
2. Swing the thermostat out from the bottom.
3. Lift the thermostat up and off the backplate.

4. Place the rectangular opening in the backplate over the equipment control wires protruding from the wall and, using the backplate as a template, mark the location of the two mounting holes

NOTE: There are several versions of the RS300N thermostat. The wiring instructions for the equipment are identical.

5. Use the supplied anchors and screws for mounting on drywall or plaster; drill two 3/16" (5mm) diameter holes at the marked locations; use a hammer to tap the nylon anchors in flush to the wall surface and fasten backplate using the supplied screws. (Do not over tighten!)
6. Connect the wires from your system to the thermostat terminals as shown in the wiring diagrams. Carefully dress the wires so that any excess is pushed back into the wall cavity or junction box. Ensure that the wires are flush to the plastic backplate. The access hole should be sealed or stuffed to prevent drafts from affecting the thermostat.

NOTE: This product must be supplied from a UL/CSA LISTED Class 2 power supply. Operation from other supplies may result in a potential fire risk.

DESCRIPTION OF THE DIP SWITCH FUNCTIONS

DIP Switch 1 : GE/HP Operation

Place DIP Switch 1 to OFF position for Gas/Electric furnace operation.

Place DIP Switch 1 to ON position for Heat Pump operation.

DIP Switch 2 : CLK Terminal Operation

Place DIP Switch 2 to OFF position to allow a short across the CLK terminals via contact closure or Robertshaw® Occupancy Sensor to engage Night (Unoccupied) operation until released. Place DIP Switch 2 to ON position to allow a short to change the thermostat to OFF mode until released.

DIP Switch 3 : 2 Minute or 4 Minute Minimum Off Times

When DIP Switch 3 is in the ON position, the minimum OFF time is 2 minutes. When in the OFF position it is set to 4 minutes. The system will allow equipment recovery for 2 or 4 minutes before turning on again. This is also known as short cycle protection.

DIP Switch 4 : Unlocked/Locked Keypad

When DIP Switch 4 is in the ON position, all buttons are disabled with the exception of the UP, DOWN and MODE button. Users will be restricted to either a +/-3°F(1°C) or +/-5°F(2°C) range from the Day (Occupied) setpoints as defined by DIP Switch 7. Users will still be able to alternate between HEAT and COOL.

DIP Switch 5 : Plenum Fan Switch /Add-On Heat Pump

DIP Switch 5 is used to determine when the fan needs to be turned on.

Place DIP Switch 5 to OFF and DIP Switch 1 to OFF to have the fan turn on immediately when there is a call for heat. (Required with electric heat.)

Place DIP Switch 5 to ON and DIP Switch 1 to OFF to have the plenum switch operate the fan.

Place DIP Switch 5 to OFF and DIP Switch 1 to ON for normal heat pump operation.

Place DIP Switch 5 to ON and DIP Switch 1 to ON for Add-On (Dual-Fuel) Heat Pump operation.

DIP Switch 6 :

Multi-Stage System Operation Place DIP Switch 6 to OFF position for single-stage applications. (single-stage compressors and heaters)

Place DIP Switch 6 to ON position for multi-stage applications. (two-stage compressors and heaters)

DIP Switch 7 : Temporary Override Adjustment Range

Place DIP Switch 7 to OFF to limit temporary adjustments to +/-3°F(1°C).

Place DIP Switch 7 to ON limit temporary adjustments to +/-5°F(2°C).

DIP Switch 8 : Remote Sensor Operation

Place DIP Switch 8 to OFF to only use the remote indoor sensor (10-528 or RS300-528) for temperature control.

Place DIP Switch 8 to ON to average the thermostat's internal sensor with the remote indoor sensor(s).

NOTE: If no remote sensor is used, the thermostat will default to the thermostat sensor regardless of the DIP Switch setting.

FEATURES AND SETTINGS

LED #1 (GREEN): Filter Indicator

This LED will illuminate when a signal is received from Terminal LED1 on the Terminal block. The Green (left) LED at the top of the thermostat and if selected by the software, the FILTER icon in the display will turn on, indicating the filter needs to be changed.

LED #2 (YELLOW): Service Indicator

This LED will illuminate when a signal is received from Terminal LED2 on the Terminal block. This terminal is usually connected to the L terminal on a Heat Pump. When a signal is received, the yellow (right) LED at the top of the thermostat will turn on and if selected by the software, the WRENCH icon in the display will turn on, indicating service is required.

LED #3 (RED): Auxiliary/Emergency Heat Indicator (no associated screw terminal)

The thermostat is equipped with an LED that indicates when the system has engaged auxiliary heat mode or emergency heat mode. It is the red (center) LED.

RS1 – RS2 – RS+V: Remote Sensor Bus

Used for connection of a wide variety of Robertshaw® remote sensors, allowing installation flexibility and additional information from the communications bus. It also allows the thermostat to be placed in an area away from view.

Add-On (Dual-Fuel) Heat Pump Control

If needed, the thermostat will perform the function of a fossil fuel kit. When in this mode, the thermostat will turn off the compressor with a call for AUX heat. When Switch 1 and Switch 5 are in the ON position, the thermostat allows the compressor and the AUX heat to be on simultaneously.

Random Restart

After a power failure, the thermostat will delay the heating/cooling equipment start-up by 8-40 seconds. When multiple Robertshaw® RS300N thermostats are used, this minimizes the 'in rush' current (electric power usage) as it reduces the number of HVAC units that will be turned on simultaneously.

High & Low Balance Point Configuration

If the thermostat is being used as a Heat Pump thermostat (DIP Switch #1 in the ON position and an outdoor sensor (10-529 or RS300-529) is connected to the remote sensor terminals, the thermostat can be configured to disable the use of auxiliary heat during warmer weather and to lock out the compressor during colder weather.

To display/set the High and Low balance points, use the integrated setup menu or:

1. Press RESUME and DAY/NIGHT together to show the outdoor temperature.
2. Press and hold the MODE and RESUME buttons for 5 seconds to evoke the High and Low balance point temperatures.

The display will indicate the high or low balance point and the selected temperature. Press the UP or DOWN button to adjust the balance point temperature. Pressing the MODE button again will toggle to the alternate balance point.

NOTE: Refer to the heat pump equipment manual for temperature cut-offs on the equipment.

FEATURES AND SETTINGS, continued

Override Timer Configuration

The temporary override time can be adjusted from 0min to 24 hours, in 10 minute increments. (0min is a complete lockout). The default time is 8 hours. To display/set the Override time, either use the integrated Setup Menu or press the MODE and DAY/NIGHT buttons simultaneously, then press the UP or DOWN button.

Recirculation Fan Configuration

Using the Setup Menu, Recirculation Fan can be set for up to 30 minutes of fan operation per hour. Default is 0min.

Fan Purge Configuration

Using the Setup Menu, Fan Purge time can be set for up to 60 seconds of fan run after a heating or cooling call in order to release remaining conditioned air into the space. Default is 0sec.

Temperature Calibration (De-calibration)

The thermostat is pre-calibrated at the factory, but in some installations, lack of airflow at the sensor or proximity to other warming or cooling source may cause the temperature to be off by a few degrees. To adjust the room temperature reading (with or without a remote indoor sensor connected), press and hold the Fan button for 12 seconds. The display will then show the room temp with 0.06F degree resolution. Press the UP or DOWN button to make the adjustment. Press the RESUME button to store the new value. To restore the thermostat to factory calibration, while in calibration mode, press the MODE button to reset and then the RESUME button to store.

Deadband Configuration

Using the Setup Menu, when in Auto Mode the minimum difference between heating and cooling setpoints can be adjusted from 2°F(1°C) to 8°F(4°C). The default is 2°F(1°C).

COVER LOCK

The cover may be locked to prevent unauthorized access by adding the clear plastic lock (included in the installation bag).

Remove the thermostat from the backplate and place the clear plastic lock in the backplate as shown below. Replace the thermostat and close the cover. The cover now is locked. To open, use a screwdriver to carefully push the lock back, allowing the cover to open.

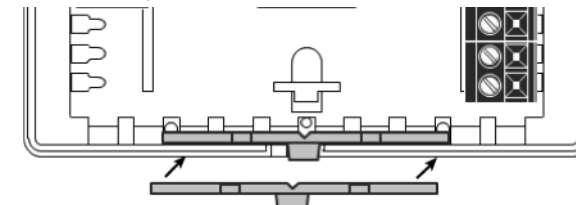

REPLACING THE THERMOSTAT ON THE BACKPLATE

1. Position the thermostat on the hinged tabs located at the top of the backplate.
2. Gently swing the thermostat down and press on the bottom center edge until it snaps in place.

BUTTON PRESS COMBINATIONS

Single Press

- **MODE** Changes from COOL to HEAT to AUTO to EMERGENCY HEAT to OFF.
- **FAN** Sets the fan ON (continuous), or AUTO (operates with the equipment), or CIRC (recirculation).
- **RESUME** When the keypad is locked, cancels temporary setpoint overrides and resumes previous operating mode.
- **DAY/NIGHT** Alternates between Day (Occupied) and Night (Unoccupied) setpoints.
- **UP** Increments the blinking numerical or icon segments of the display.
- **DOWN** Decrements the blinking numerical or icon segments of the display.

Multi-Press

- **UP & DOWN** Toggles between °F and °C.
- **RESUME & DAY/NIGHT** Displays Remote Sensor values in the upper display. Press both, then press UP or DOWN to rotate through the available sensors.
- **FAN & DAY/NIGHT** Changes backlight setting. On, dim or off. (After 15 seconds of inactivity)
- **MODE & DAY/NIGHT** Changes the Override Timer. Press both, then press UP or DOWN to change the override time from 0 minutes to 24hrs in 10 minute increments

PRESS & HOLD (12 seconds unless stated otherwise)

- **UP & DOWN** (HOLD for 2 seconds) Enters the Setup Menu
- **MODE** Resets the thermostat to factory defaults. Press and hold the MODE button to show the number of resets. Press the MODE button a second time to reset the defaults.
- **FAN** Enters thermostat sensor de-calibration mode. Allows a temperature offset of up to +/-6°F. To remove the de-calibration, press and hold the MODE button.
- **MODE & RESUME** Allows for adjustment of High and Low balance points when displaying outdoor temperature (hold for 5 seconds). **NOTE:** There must be an outdoor sensor attached for this feature to be available.

KEYPAD LOCKOUT

When DIP Switch #4 is ON, the keypad is locked and temporary adjustment to the setpoints are restricted to a setpoint range of +/-3°F(1°C) or +/-5°F(2°C) from the Day (Occupied) setpoints for the amount of time set in the override timer.

TEMPORARY OVERRIDE (in KEYPAD LOCKOUT MODE)

Change the temperature setting temporarily without affecting the Day (Occupied) and Night (Unoccupied) setpoints, even though the keypad is locked.

- Press the UP or DOWN button. If running in Day (Occupied), the current occupied setpoint will be shown, and if running in Night (Unoccupied), the current occupied setpoint will be shown.
- Press the UP or DOWN button again. The current Day (Occupied) setpoint will be shown and an Override will be started. If in AUTO mode, press the MODE button to switch between heating and cooling setpoints.
- Press the UP or DOWN button again to adjust the temperature up to the maximum of +/-3°F(1°C) or +/-5°F(2°C) for the duration of the override time.
- To cancel, simply press the RESUME button.

SETBACK INPUT TERMINALS

The CLK terminals allow for two powerful methods to operate the thermostat in special conditions when an external stimulus is used to short the CLK1/CLK2 terminals. This allows an external time clock or other external relay, or a Robertshaw® Occupancy Sensor to be incorporated into the control.

- Setback with No Override

With DIP Switch 2 in the OFF position, DIP Switch 4 in the OFF position (Keypad Unlocked), and then the CLK terminals are shorted, the thermostat will lock into Night (Unoccupied) operation (and setpoints) as long as the terminals are shorted. Keypad DAY/NIGHT presses and will be ignored until the short is removed.

- Setback with Override

With DIP Switch 2 in the OFF position, DIP Switch 4 in the ON position (Keypad Locked), and then the CLK terminals are shorted, the thermostat will go into Night (Unoccupied) operation (and setpoints) as long as the terminals are shorted. Keypad DAY/NIGHT presses and will be ignored until the short is removed, but an override to Day (Occupied) setpoints can be achieved by pressing the UP or DOWN buttons. The override will last as long as the override timer. See 'TEMPORARY OVERRIDE'. When the short is removed, the thermostat will return to its last state and the communications can again set Day/Night operation.

- Set Mode to OFF with CLK Terminals

When DIP Switch 2 is in the ON position and the CLK terminals are shorted, the thermostat will change to OFF mode and only the FAN button can be used until the short is removed. This feature allows a 3rd party set of contacts (such as door or window sensors) to be connected to the CLK terminals to shut down the HVAC equipment when a door or window is open. The installer is responsible for any necessary time delay to be added to the contacts as needed to perform the desired function. When the short is removed, the thermostat will revert to its previous operation.

CHANGING FAHRENHEIT (°F) TO CELSIUS (°C)

To change between °F and °C, use the integrated set up menu or simultaneously press the UP and DOWN buttons. The display will change automatically.

POWER FAILURES

This Robertshaw® thermostat product will maintain the operation settings during any type of power failure. When power is restored the thermostat will return to the last MODE (Heat, Cool, Auto, Off) and the DAY (Occupied) setpoints. If the CLK terminals are shorted at power up, the thermostat will operate using the last NIGHT (Unoccupied) setpoints.

REMOTE SENSORS (OPTIONAL)

If your Robertshaw® thermostat has been installed with one or more Robertshaw® remote sensors, the sensor information is available on the small secondary display of the thermostat. There are many different remote sensors. The robertshawclimate.com website shows detailed information. You can view the remote sensor information by simply pressing and holding the RESUME and DAY/NIGHT buttons simultaneously, and then use the UP or DOWN button to view the various sensors.

SETUP MENU

The RS300N family of thermostats has an integrated Setup Menu, allowing quick access to the following setup functions. To access the menu, simultaneously press and Hold the UP and DOWN buttons for seconds. When the display changes, use the UP or DOWN buttons to select the option needed, the MODE button to go to the next setup function, and the RESUME button to save and exit. If there are no additional button presses for 15 seconds, the thermostat will store, exit and return to normal operation. All settings are stored in non-volatile memory.

Setup Menu Order:

1. °F or °C Temperature Display
2. Backlight Brightness Level: On, Low, or Off
3. Mode Options: Automatic Changeover, Cooling Only or Heating Only
4. Deadband: Set from 2°F(1°C) to 8°F(4°C)
5. Min/Max Setpoint Range: Heat High, Heat Low, Cool High, Cool Low
6. Calibration: For creating a temperature offset
7. Fan Recirculation: 0min to 30min per hour
8. Fan Purge: 0sec to 60sec after call
9. Override Timer: Set from 0min to 24Hr
10. Balance Points: For Heat Pumps, both Compressor Lockout and Aux Heat Lockout
11. LED1 Use: With or without Filter Icon
12. LED2 Use: With or without Fault Icon

EQUIPMENT WIRING DIAGRAM : RS332N Generic Connections

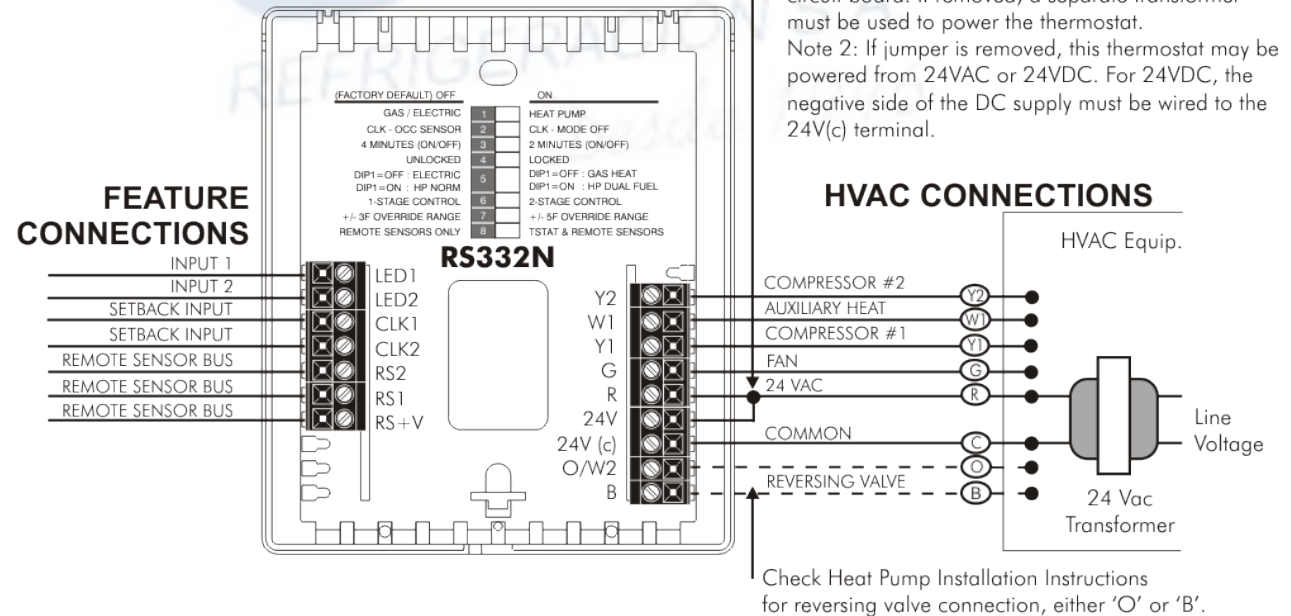

EQUIPMENT WIRING DIAGRAM : RS332N

1-Stage Gas Furnace & Air Conditioning

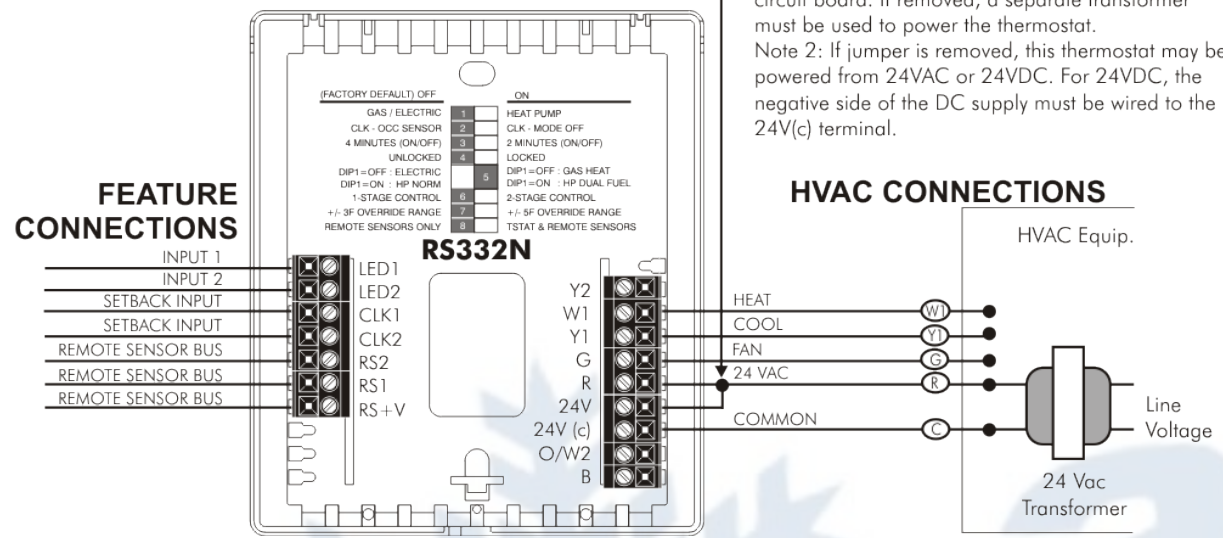

EQUIPMENT WIRING DIAGRAM : RS332N

1-Stage Electric Furnace & Air Conditioning

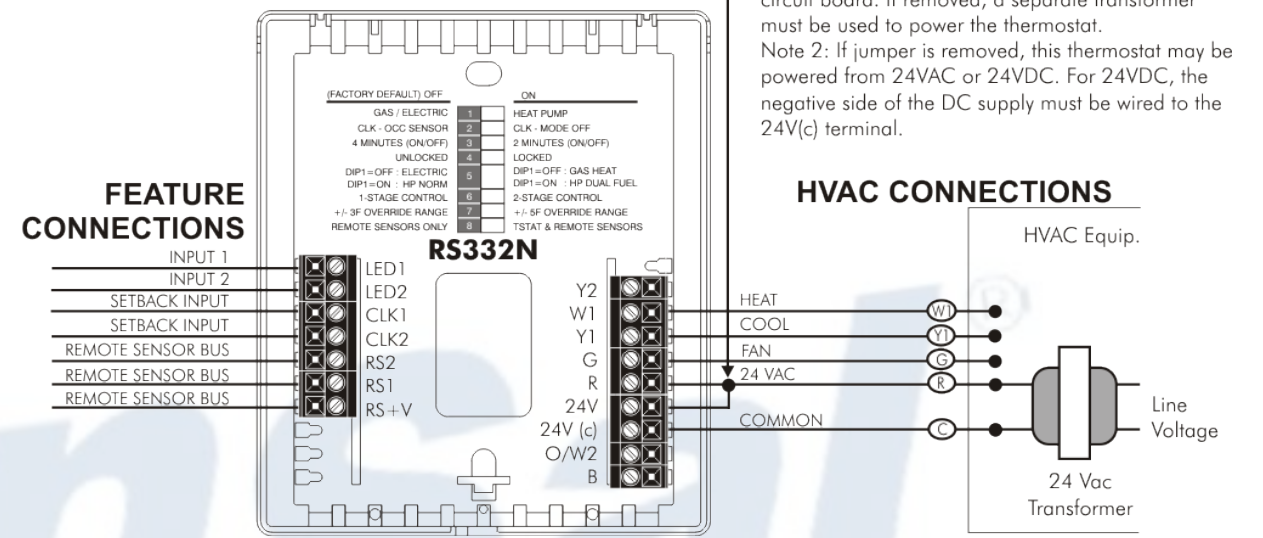

EQUIPMENT WIRING DIAGRAM : RS332N

2-Stage Gas Furnace & Air Conditioning

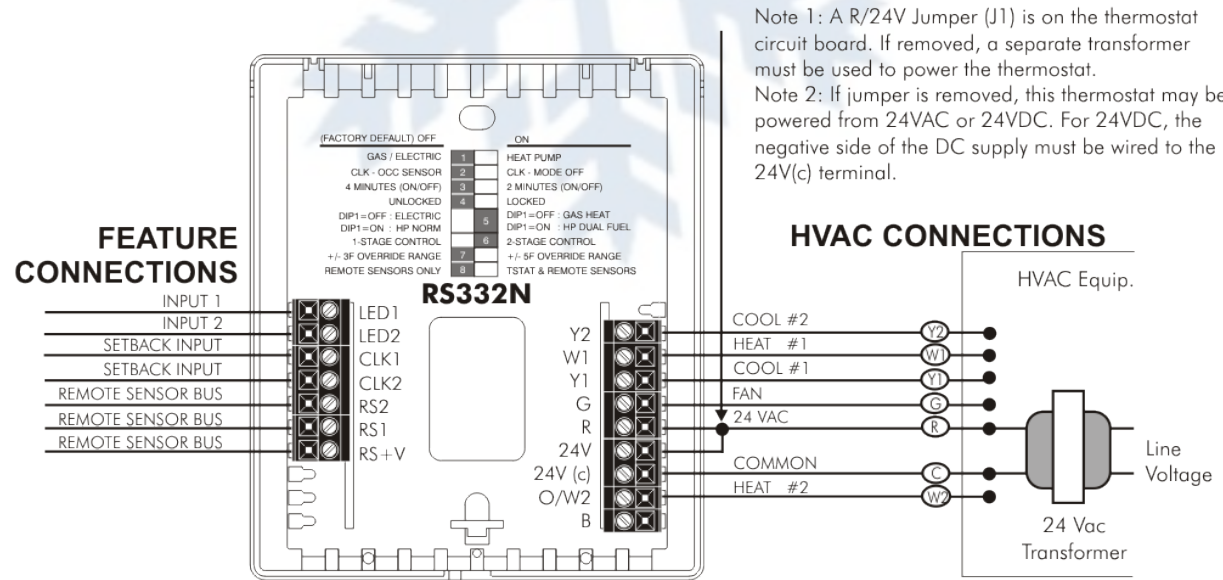

EQUIPMENT WIRING DIAGRAM : RS332N

2-Stage Electric Furnace & Air Conditioning

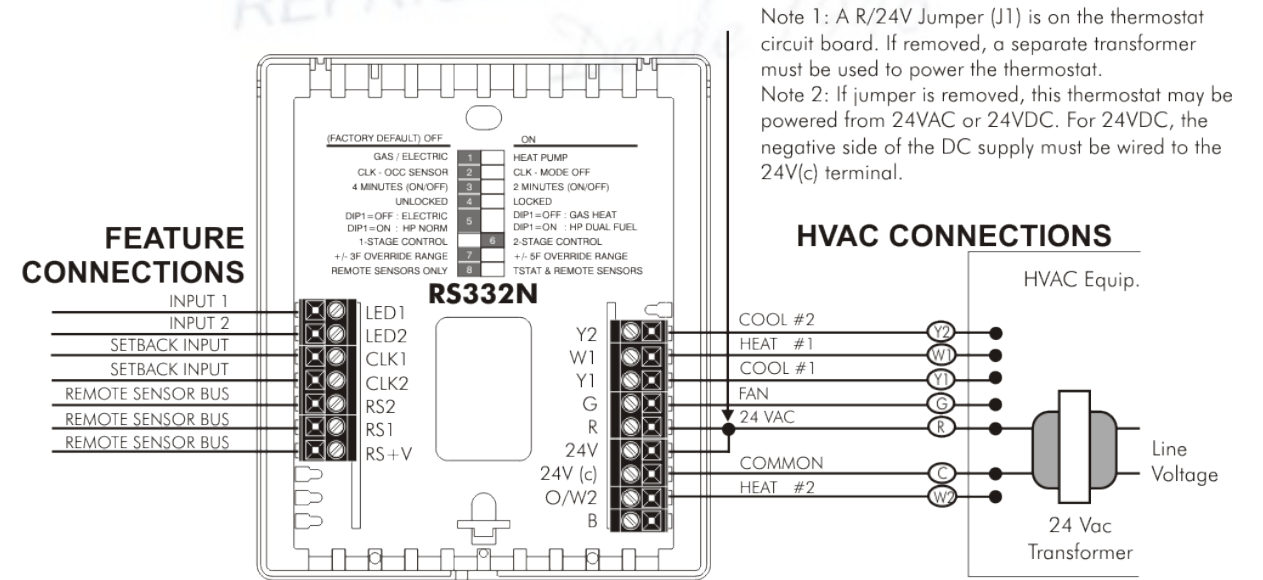

EQUIPMENT WIRING DIAGRAM : RS332N 1-Stage Heat Pump, Standard Operation

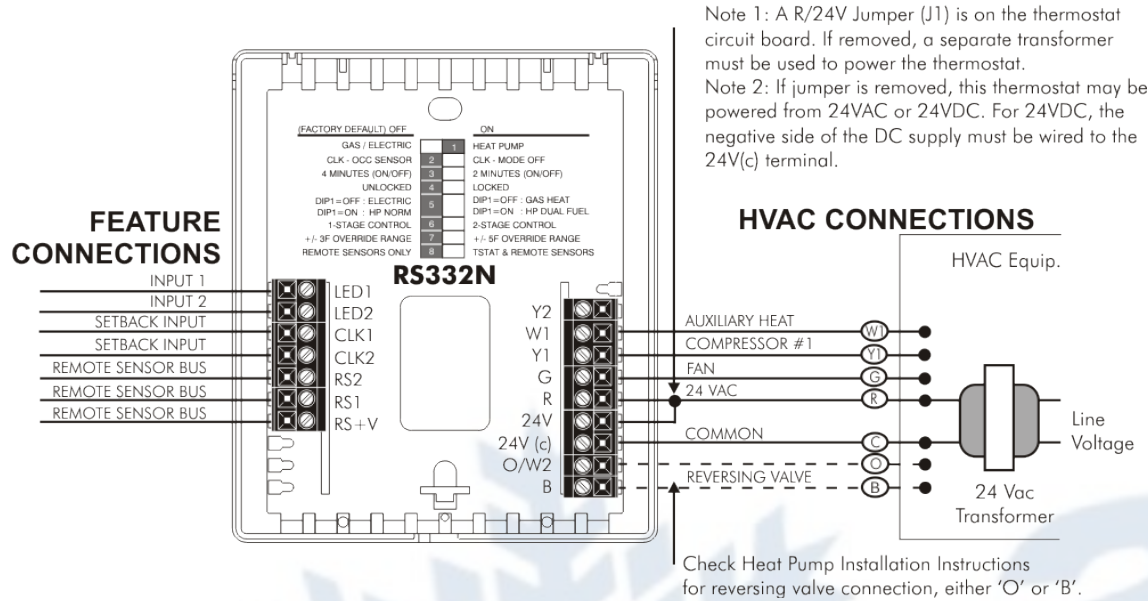

EQUIPMENT WIRING DIAGRAM : RS332N 1-Stage Heat Pump, Add-On (Dual-Fuel) Operation

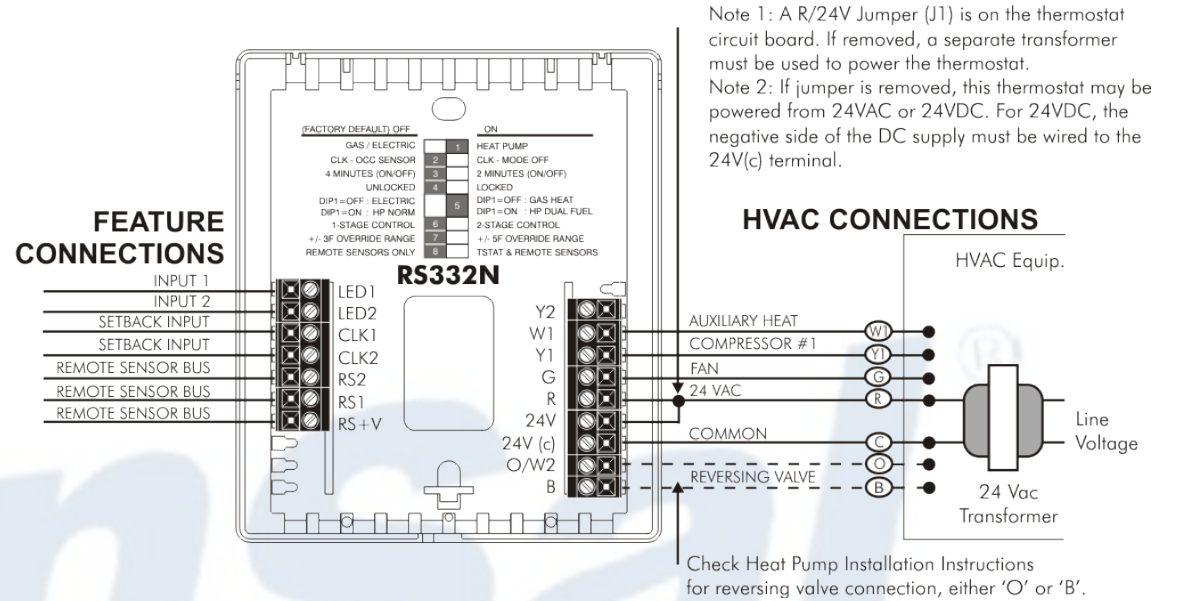

EQUIPMENT WIRING DIAGRAM : RS332N 1-Stage Heat Pump, Add-On (Dual-Fuel) Operation

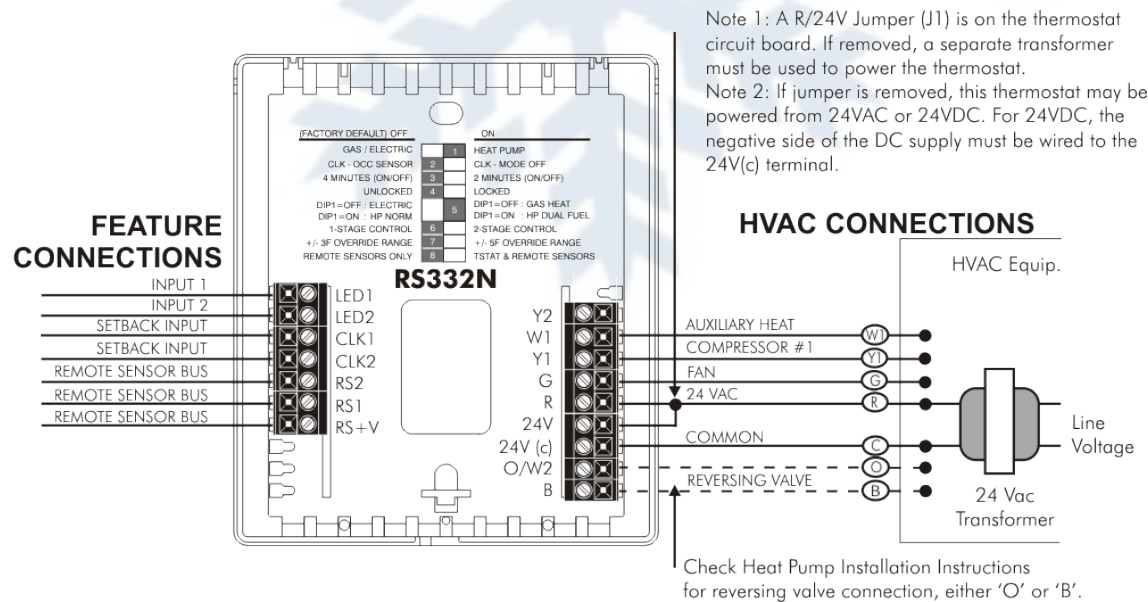

EQUIPMENT WIRING DIAGRAM : RS332N 2-Stage Heat Pump, Add-On (Dual Fuel) Operation

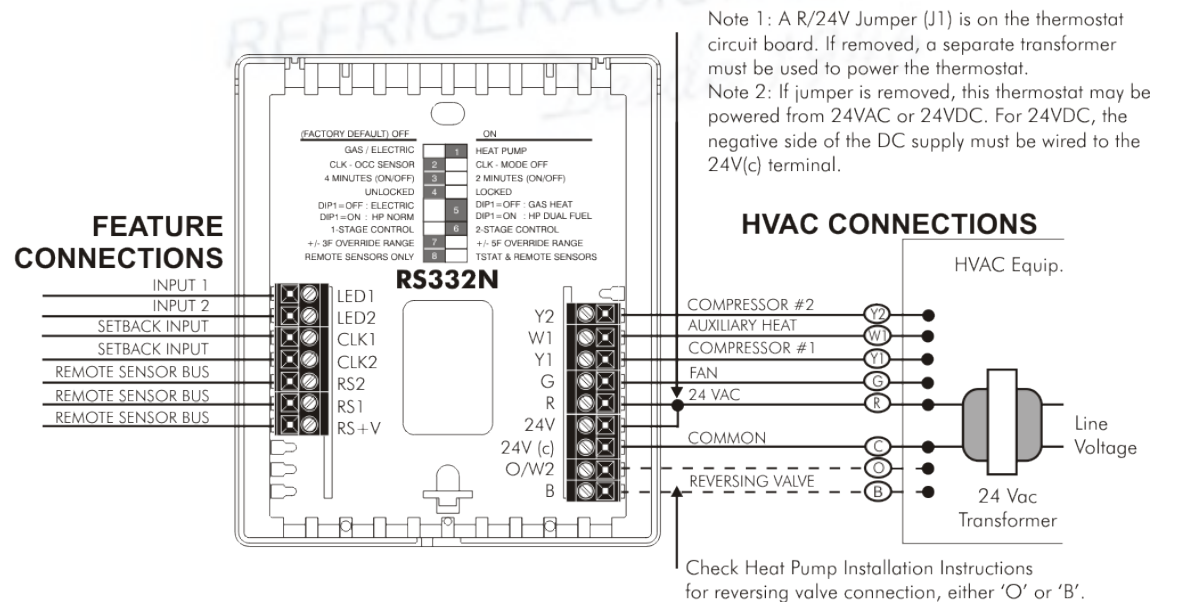

SPECIFICATIONS

Rated Voltage	20-30 VAC. 24 nominal
Rated A.C. Current	0.050 Amps to 0.75 Amps continuous per output with surges to 3 Amps Max
Rated D.C. Current	0 Amps to 0.75 Amps continuous per output with surges to 3 Amps Max
Control Range	Heating: 38° to 88°F in 1° Steps (3° to 31°C in 1° Steps) Cooling: 60° to 108°F in 1° Steps (16° to 42°C in 1° Steps)
Thermostat Measurement Range	32° to 118°F (0° to 48°C)
O.D.T Displayed Range	-54° to 118°F (-48° to 48°C)
Control Accuracy	± 1°F at 68°F Accuracy (±0.5°C at 20°C Accuracy)
Minimum Deadband	2°F (1°C) (between heating and cooling)

NOTE: This thermostat contains electronic circuitry replacing the conventional mechanical anticipator

SENSOR FAULTS

There are four distinct sensor faults:

1. Internal sensor is shorted.
2. Internal sensor is open.
3. A remote indoor sensor is shorted.
4. A remote indoor sensor is open.

When the internal sensor is shorted [the sensed temperature $\geq 124^\circ\text{F}$ (48°C)], all equipment is turned off and the following icons are flashed on the LCD:



When the internal sensor is open [the sensed temperature $\leq 32^\circ\text{F}$ (0°C)], all equipment is turned off and the following icons are flashed on the LCD:



An open condition is ignored for the first 20 minutes after powering the thermostat to allow the equipment to heat the surrounding environment. This will avoid premature deactivation of the equipment if the ambient temperature should happen to be below 32°F (0°C).

DESCRIPTION OF ICONS

	-188 % SET	Secondary Display All Segments	
	-188 SET	Heating or Cooling Setpoint	
	-188	Outdoor Temperature	
	-188	Any of the auxiliary remote sensors	
	Fault		Keypad Locked
	Filter		
	Fan		Recirculation Fan
	Cooling = Snowflake (blinking is active)		
	Heating = Flame (flickering is active)		
	Both with AUTO = Auto Mode		
	Either with 2 = 2nd stage active		
	E with Heating = Emergency heat (Heat Pump)		
	Indicates Day or Night setpoints in operation when Keypad is unlocked		
	Displayed when Keypad is locked and operation is in override		
	Either OCC or UNOCC is displayed when Keypad is locked & operation is OCC(Day) or UNOCC(Night)		

DESCRIPTION OF ICONS, continued

	5 second display when heat mode is selected and when the heating setpoint is changed		Displayed when in the emergency heat mode
	5 seconds display when cool mode is selected and when the cooling setpoint is changed		Displayed when in the off mode
	5 second display when auto mode is selected		Displayed for 30 minutes when power is lost

DISPLAY

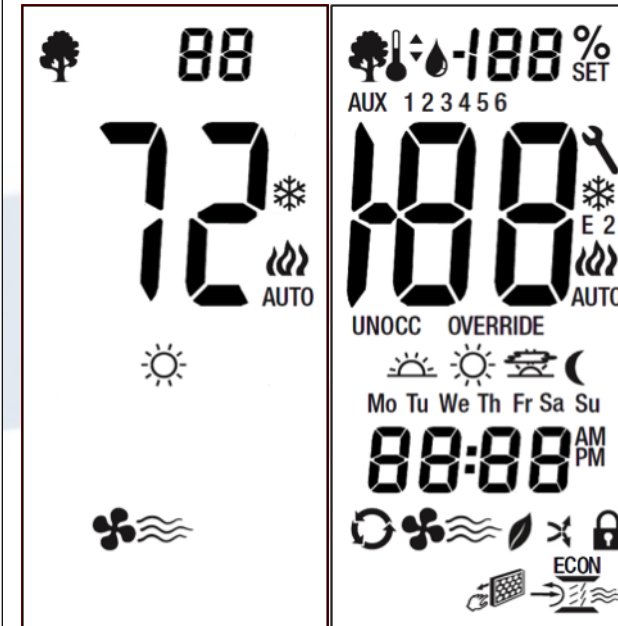

Five (5) YEAR LIMITED WARRANTY

Robertshaw® warrants to the original purchaser that this product and its component parts will be free from defects in workmanship and materials for a period of five years from the date of purchase with proof of purchase.

Warranty Limitations

This warranty begins on the date of purchase.

Warranty is Void if:

- The date code is defaced or removed.
- The product has a defect or damage due to product alteration, connection to an improper electrical supply, shipping and handling, accident, fire, flood, lightning or other conditions beyond the control of the manufacturer.

Five (5) YEAR LIMITED WARRANTY, continued

- The product is not installed according to the manufacturers instructions and specifications.
- The product has been installed near sources of electromagnetic interference (EMI) such as arcing relay contacts.

Owner's Responsibility

- Provide proof of purchase.
- Provide normal care and maintenance.
- Pay for freight, labor and travel.
- Pay for service calls related to product installation.
- Return any defective product.
- In no event shall the manufacturer be liable for incidental or consequential damages.

This warranty gives you specific legal rights and you may have others which vary by state and/or province. For example, some states and/or provinces do not allow the exclusion or limitation of incidental or consequential damages, so this exclusion may not apply to you.

The manufacturer's continuing commitment to quality products may require a change in specifications without notice.

Robertshaw® RS300N Series Non-Programmable Setback Thermostats meet CA Title 24 requirements.

This equipment, if installed in strict accordance with the manufacturer's instructions, complies with the limits for a Class B computing device pursuant to Subpart J of Part 15 of FCC rules.

FCC Regulatory Information

This equipment has been tested and found to comply with the limits for a Class B digital device, pursuant to part 15 of the FCC rules. These limits are designed to provide reasonable protection against harmful interference in a residential installation. This equipment generates, uses and can radiate radio frequency energy and, if not installed and used in accordance with the instructions, may cause harmful interference to radio communications. However, there is no guarantee that interference will not occur in a particular installation. If this equipment does cause harmful interference to radio or television reception, which can be determined by turning the equipment off and on, the user is encouraged to try to correct the interference by one or more of the following measures:

- Reorient or relocate the receiving antenna.
- Increase the separation between the equipment and receiver.
- Connect the equipment into an outlet on a circuit different from that to which the receiver is connected.