



HERMETIC COMPRESSOR SPECIFICATION

Model : PA240X2CS-4KU1

Accept Marking:

This document will be effective with your authorized signature. Please return one (1) copy of this form, and keep the other one (1) copy for your records.

1、适用范围 (Application)

| | |
|--|--|
| 空调器类型 A/C Type | 冷暖兼用型空调器 Cooling & Heating A/C System |
| 冷媒类型 Refrigerant Type | R410A |
| 最大冷媒充注量 Maximal Refrigerant Charged | 1.80Kg Max |
| 电源类型 Power Source | 单相 Single Phase 1ϕ-50Hz-220-240V |
| 安全认证 Safety Approval | TUV |

2、规格参数 (Specification)

| | |
|--------------------------------------|--|
| 压缩机类型 Compressor Type | 全封闭型电动压缩机 Hermetic Motor Compressor |
| 汽缸容积 Displacement | 23.9cm³/rev. |
| 冷冻机油充注量 Oil Charged | ESTER OIL VG74 · 650 ml |
| 总重量 (含冷冻机油) Weight (Oil Included) | 17.8Kg |
| 排气管内径 I. D. of Discharge Pipe | 8.1 \pm 0.1mm |
| 吸气管内径 I. D. of Suction Pipe | 12.9 $\begin{matrix} +0.2 \\ -0.1 \end{matrix}$ mm |

3、电机参数 (Motor Specification)

| | |
|---|--|
| 电机类型 Motor Type | 单相诱导电机·运转电容型 Single Phase Induction Motor · PSC |
| 电机极数 Pole Numbers | 2 极/Poles |
| 绝缘等级 Insulation Grade | E 级/Grade |
| 绕组阻值 (20°C时) Coil Resistance (at 20°C) | 主绕组 辅绕组 Main: 1.54 \pm 5% Ω Aux. : 2.49 \pm 5% Ω |
| 堵转电流 Locked Rotor Amps | (at 1ϕ-50Hz-240V) \pm 10% 44.3 A |
| 运转电容 Ruing Capacitor | 50μF-370V |

4、额定性能规格 (Rated Performance Parameters)

| | | |
|---------------------------------|-----------|-------|
| 额定能力 Rated Capacity | 5800/5850 | ±5% W |
| 额定输入功率 Rated Input Power | 1985/2060 | ±5% W |
| 额定输入电流 Rated Input Current | 9.30/9.20 | ±5% A |
| 能效比(*备注) % COP(*Remarks) % | 292/284 | ±5% |
| 噪音/NOISE (Sound Power Level) | ★ 72 以下 | MAX |
| 振动 VIBRATION (法线方向振动实效值) | ★ 3.3 以下 | MAX |

测定条件 (Rating Condition)

| | | |
|---------------------------|------------------|--------------|
| 电源 Power Source | 1φ-50Hz-220-240V | 1φ-50Hz-220V |
| 冷凝温度 Cond. Temp. | 54.4°C | ★54.4°C |
| 蒸发温度 Evap. Temp. | 7.2°C | ★7.2°C |
| 吸气温度 Return Gas Temp. | 35°C | ★18°C |
| 过冷却温度 Liquid Temp. | 46.0°C | |
| 环境温度 Ambient Temp. | 35°C | |
| 排气温度 Discharge Tube Temp. | 85°C (ForcedAir) | |

5、电气配线接线图 (Wire Connection Figure)

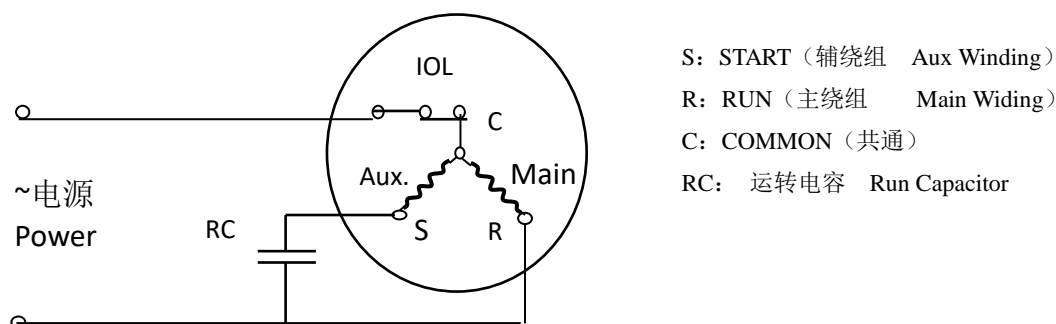

6、一般特性(Charateristic)

| | | |
|-------------------------------|-------------------------------|----------------------------|
| 绝缘阻抗 Insulation Resistance | $\geq 30 \text{ M}\Omega$ | 封入氮气时 /Nitrogen Charged |
| 绝缘耐压 Withstanding Voltage | AC1500V-1min | |
| 接地阻抗 EARTHING RESISTANCE | 以下 0.1 Ω MAX | |
| 残留水分量 Residual Moisture | 冷凝法 $\leq 200\text{mg}$ | |
| 含尘量 Residual Impurities | $\leq 45\text{mg}$ | |

7、系统使用条件(Limit of System Application)

| NO. | 项目 Item | 标准(参考) Standard (reference) | 极限状况下 Limit Cond. | 说明 Note |
|-----|---|--------------------------------|-----------------------------|--|
| 1 | 排气压力 Discharge Pressure (对应饱和温度). | 3.28 MPa (55°C) | 4.15 MPa (65°C) | 详细压力使用范围见 附纸! See the attached chart of limitation of operation pressure. |
| 2 | 吸气压力 Suction Pressure. (对应饱和温度) | 0.89 MPa (-5~10°C) | 0.23~1.15 MPa (-25~15°C) | |
| 3 | 压缩比 Compressing Ratio | 8 Max | 8 Max | |
| 4 | 电机绕组温度 Motor Coil Temp. | 100°C | 125°C | |
| 5 | 排气温度 Discharge Temp. | 100°C | 115°C | |

8、注意事项 Application Notice:

1. 整个运行过程中无液压缩发生。

No liquid refrigerant go back to compressor during the whole time.

2. 连续运转时(包括除霜、除湿)压缩机底部温度-冷凝器中部温度需大于等于5°C以上;

When continuous running (include defrost and dehumidify), compressor bottom temp. subtract condensing temp. should be more than 5°C.

断续运转时压缩机底部温度-冷凝器中部温度需大于等于0°C以上。

When intermittent running, compressor bottom temp. subtract condensing temp. should be more than 0°C.

3. 断续运转,每一周期5分钟以上,开2分钟以上,停2分钟以上。

When intermittent running, each cycle should be longer than 5 minutes. (On: over 2 min, Off: over 2 min)

4. 运转电压波动允许范围 **220V-10%~240V+10%(198~264V)**

The supply voltage should be **220V-10%~240V+10%(198~264V)**

5. 高压侧和低压侧压力需保持平衡后才能启动。
Pressure should be balanced between high and low pressure side.
6. 运转过程中不能有异常噪音发生。
In operation, abnormal noise is not allowed.
7. 最大允许倾斜角度：5°。
Tilt angle should be less than 5°.
8. 当压缩机以下状态时，需确认油面水平：
Oil level confirmation should be tested at:
 - 1) 超负荷、低负荷时；
Overload and low load running;
 - 2) 冷媒沉积启动时；
Refrigerant soaking starting;
 - 3) 除霜开始、恢复时；
Defrost starting and resuming;
 - 4) 超过最长配管时；
Connection pipe over 15m;
 - 5) 超过最大落差时；
Elevation over 5m;
 使用带视窗镜的压缩机进行确认；
Oil level confirmation test performed with side glass compressor:
 - 1) 在稳定运转状态（包括连续/断续运行），油面需在水平面 B 以上；
At steady running (include continuous or intermittent operation): oil level should be higher than B level.
 - 2) 在启动的 3 分钟以内，油面需在水平面 A 以上；
Within 3 minutes at starting: oil level should be higher than A level.

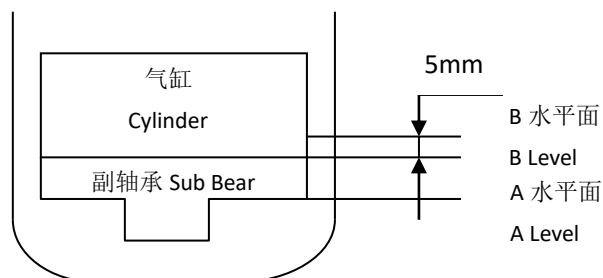

9. 请确认本产品已满足贵司的生产效率及性能下线率要求。
Please confirm that this product can meet your requirements of the productive efficiency and the performance pass rate.

9、其他注意事项 Other Application Notice

1. 不要给吐出管、吸入管施加弯曲的力，强制其弯曲。
配管设计时，要考虑产品在始动、运转停止以及运输搬运时的振动应力，不致发生损坏。
推荐各配管许容应力如下：始动、停止时 34.3N/mm² 以下，运转时 19.6N/mm² 以下
When design the connection tube, the system should be consider the vibration stress at the compressor start, stop and the system transportation status , ensure it doesn't be

- damaged. The recommendation value of the connection tube stress is below 34.3N/mm² at the start, stop status and below 19.6N/mm² at the running status.
2. 压缩机不允许横置、倒置，在搬运时不允许跌落。
Do not put a compressor on its side or turn it over. And do not fall it off when moving.
 3. 绝对不允许空气中运转。
Compressing air is not permitted.
 4. 压缩机密封塞拔除后，请尽快使用，不要将压缩机长时间放置。
Please assemble the compressor in your Air Conditioner rapidly after removing the plugs. Don't place the compressor in air for a long time.
 5. 电气品要使用弊社所指定的规格同等品。
Please use the accessories indicated by Our Company.
 6. 冷媒量超过规定量时，需另行协商决定压缩机规格。（此时要考虑增加储液器、油加热器）
When the amount of refrigerant charged in the Air Conditioner is over the max amount allowable, compressor specification should be discussed. (Install additional accumulator, oil heater, etc.)
 7. 冷媒填充原则上从高压侧开始实行。
Refrigerant must always be filled from the higher side of the refrigeration cycle.
 8. 避免因误配线发生逆转。（若发生逆转，则压缩机不能再使用）
Avoiding compressor running in reverse caused by connecting electrical wire incorrectly. (Don't reuse the compressor after running in reverse.)
 9. 压缩机不得露天存放或存放在腐蚀性空气中如化学仓库等。
The compressor should be kept out of storing in open storage or corrosive atmosphere such as in a chemicals storage and so on.
 10. 压缩机壳体表面不容许配线或类似物接触压缩机表面。
Do not allow electric cables or the like to touch compressor directly.
 11. 必须有适当的防湿、防尘处理以防止水滴，灰尘进入压缩机
To avoid water droplets and dust into the compressor, moisture-proof or dust-proof measures must be take.
 12. 分体式空调最长配管不超过 15m，配管的高低落差最大 5m。
For split type Air Conditioner, the maximum piping length should be 15m, and elevation difference should be within 5m.
 13. 禁止使用 R410A 之外的冷媒。
Do not fill refrigeration cycles with other refrigerant except R410A.
 14. 请不要裸手触摸运行中或刚停机正处于高温的压缩机，当心烫伤。
Do not touch the compressor with bare hands during operation or immediately after stoppage. The compressor is at a high temperature. There is the danger of burns.
 15. 维修保养设备时必须配戴防护眼镜。由于焊枪温度过高，拆卸配管时，当心会有冷媒、油的溅出而导致烫伤或进入眼中。
Wear safety goggles when servicing the unit. When removing the tubes by heating it with a burner, there is the danger of burns or eye injury if the refrigerant and/or oil remaining in the tubes is emitted.

压缩机运行范围 (Operation Limitation of Compressor)

单位: MPa (表压)

Unit: MPa (G)

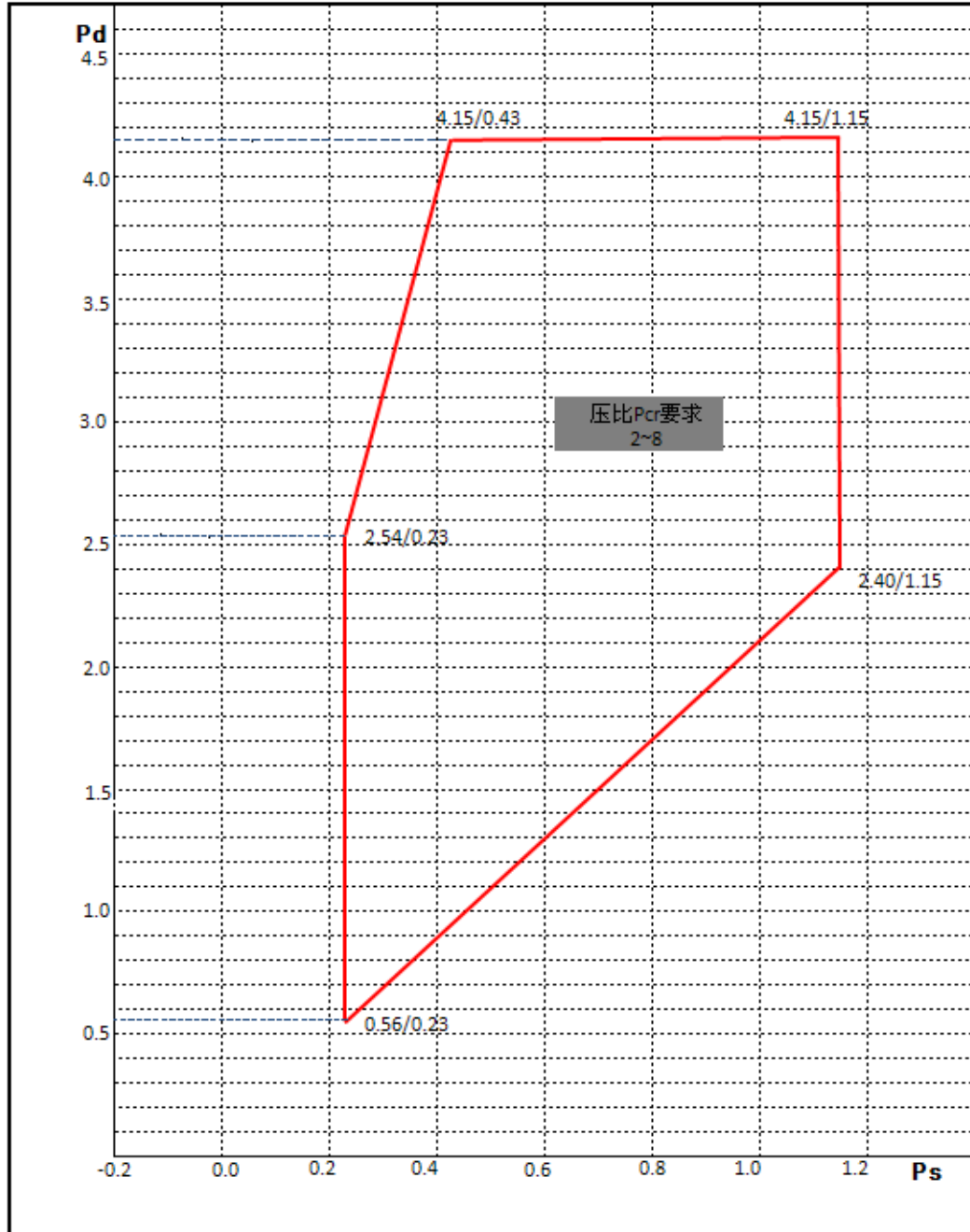

备注: 压缩机稳定运行时需满足上图运行范围 Pcr: 压缩比 Compressing Ratio
Pd: 冷凝压力 Condensing pressure Ps: 蒸发压力 Evaporating pressure

图纸/附件清单 Drawing/Accessories List

(See the Attached Pages)

| 名 称 (Parts Name) | 数量 (Pieces) | 图 号 (Drawing No.) | 备注 |
|------------------------------------|----------------|----------------------|----|
| 电装品 ELE. COMPONENTS | 1 | 1K14722114 | |
| 端子盖 TERMINAL COVER | 1 | 1K14722211 | |
| 端子垫片 TERMINAL PACKING | 1 | 1K14720132 | |
| 端子螺母 TERMINAL NUT | 1 | 1K14300711 | |
| 橡胶垫 RUBBER CUSHION | 3 | MC34910210 | |
| 接地螺钉 EARTHING HEX BOLT | 1 | 1K14300210 | |
| 接地螺钉垫片 WASHER FOR EARTHING BOLT | 1 | 1K14300310 | |
| 压缩机外形图 COMPRESSOR DRAWING | 1 | 1K159077Gr | |

ELE COMPONENTS

Drawing No. 1K14722114

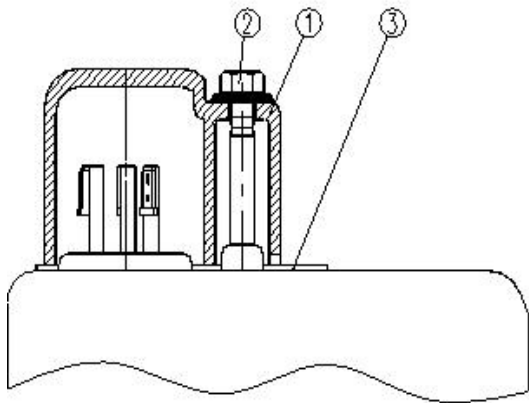
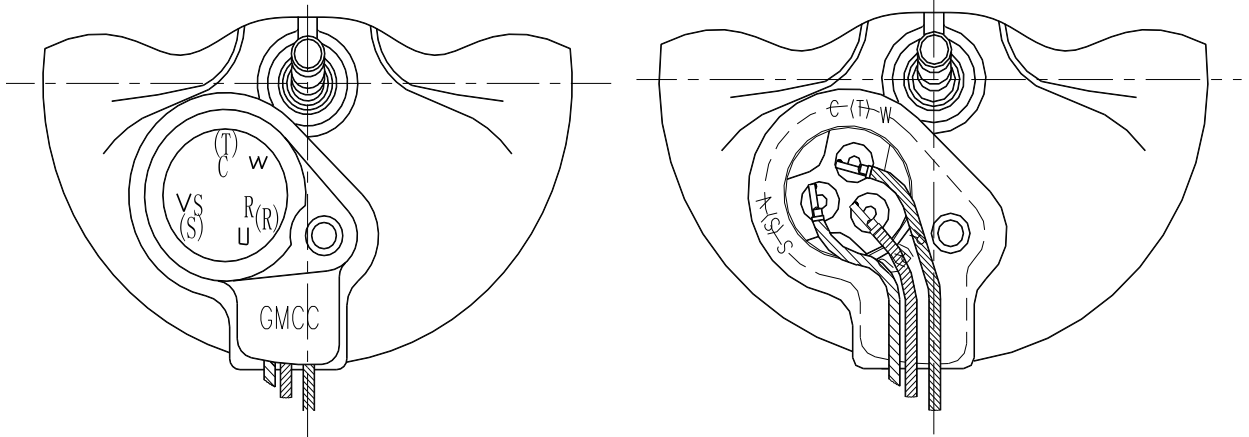

| | | |
|---------|------------------|------------|
| ③ | TERMINAL PACKING | 1K14720132 |
| ② | TERMINAL NUT | 1K14300711 |
| ① | TERMINAL COVER | 1K14722211 |
| PART NO | TITLE | DRAWN NO |

NOTES

Tightening torque of terminal nut: $1.2 \pm 0.2 \text{ Nm}$

广东美芝制冷设备有限公司
GUANGDONG MEIZHI COMPRESSOR LTD

TERMINAL COVER

Drawing No. 1K14722211

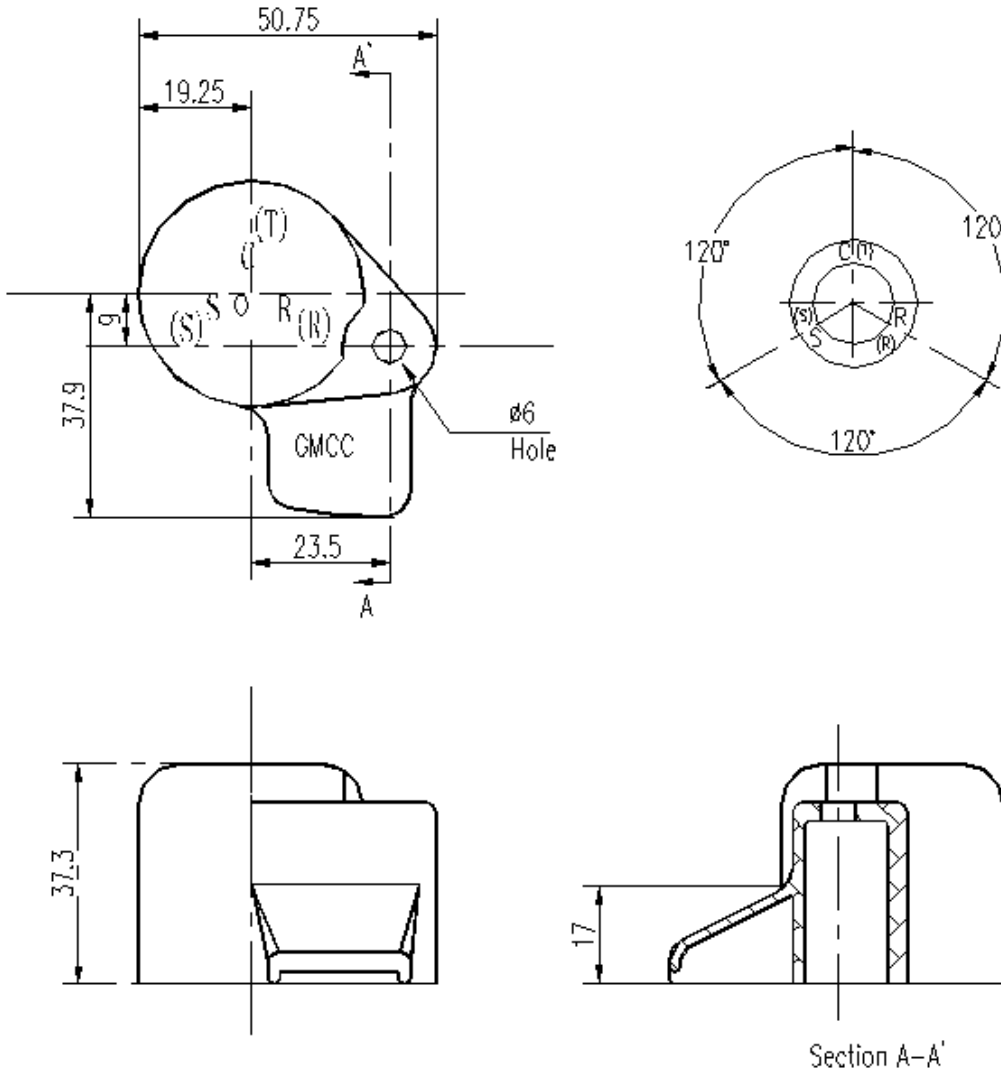

NOTES

MATERIAL:POLYBUTYLENE TEREPHTHALATE or Bulk molding compound

COLOR:BLACK

广东美芝制冷设备有限公司
GUANGDONG MEIZHI COMPRESSOR LTD

端子垫片 TERMI PACKING

Drawing No.1K14720132

厚度 $1 \pm 0.2\text{mm}$
THICKNESS $1 \pm 0.2\text{mm}$

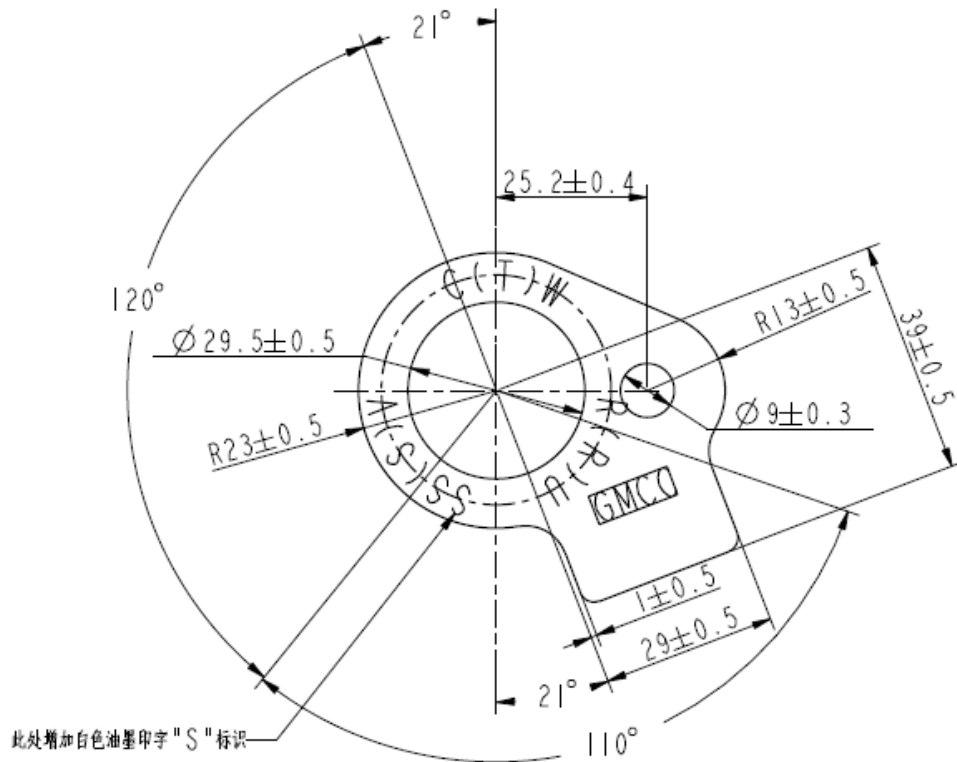

注释
NOTES
材质: 硅橡胶
MATERIAL: SI
颜色: 黑色
COLOR: BLACK

端子螺母 TERMINAL NUT

Drawing No. 1K14300711

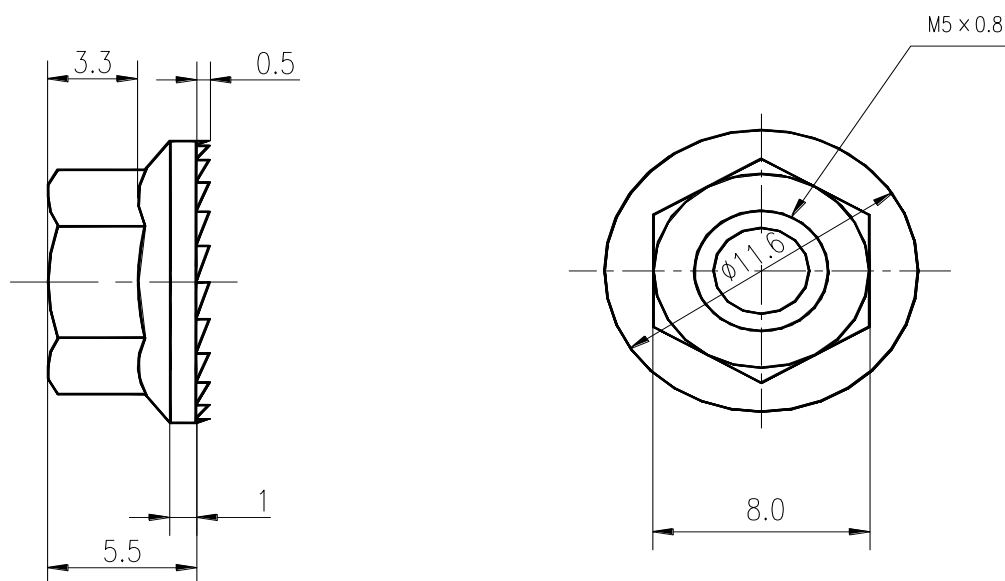

注释

NOTES

材质: SWCH12A

MATERIAL: SWCH12A

处理: 表面处理按Ep-Fe/Zn 2-CM 2镀锌处理

TREATMENT: WITHOUT HEXAVALENT CHROMIUM COMPOUNDS (Ep-Fe/Zn 2-CM 2镀锌处理)

接地螺钉 EARTHING HEX BOLT

Drawing No. 1K14300210

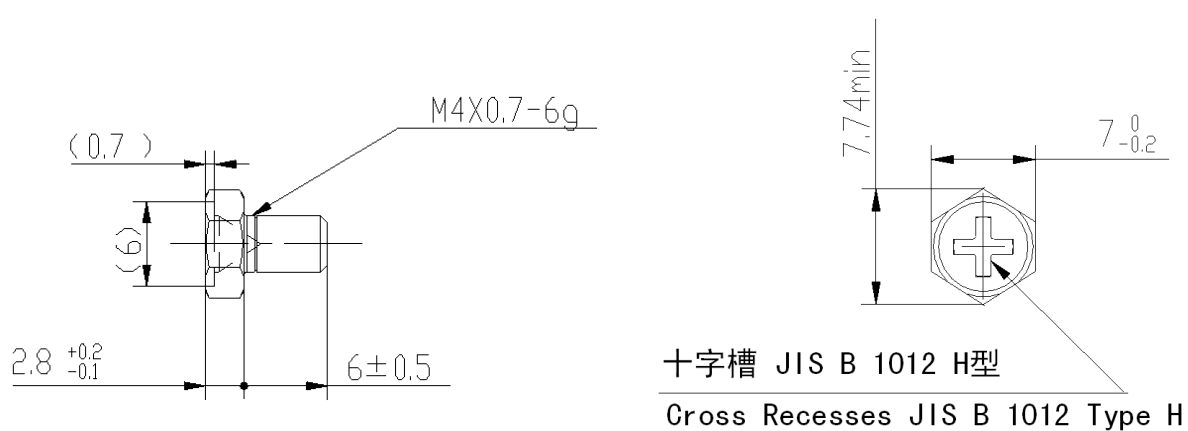

注释

NOTES

材质: C2700W-1/4H

MATERIAL: C2700W-1/4H

处理: 按 (Ep-Cu/Ni 3 b) 进行表面处理

TREATMENT: ELECTROPLATED COATINGS OF NICKEL (Ep-Cu/Ni 3 b)

接地螺钉垫片

WASHER FOR EARTHING BOLT

Drawing No. 1K14300310

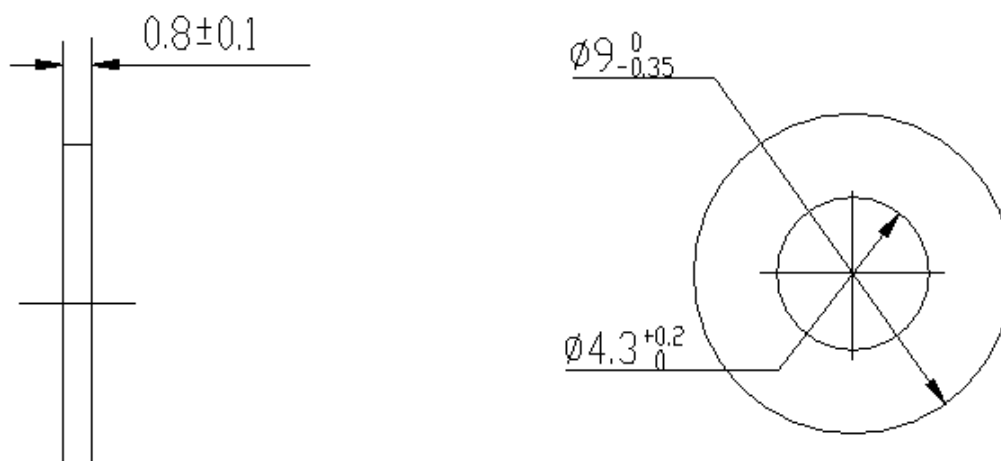

注释

NOTES

材质: C2801P

MATERIAL: C2801P

处理: 按照(Ep-Cu/Ni 3 b)进行表面处理

TREATMENT: ELECTROPLATED COATINGS OF NICKEL (Ep-Cu/Ni 3 b)

橡胶垫 RUBBER CUSHION

Drawing: MC34910210

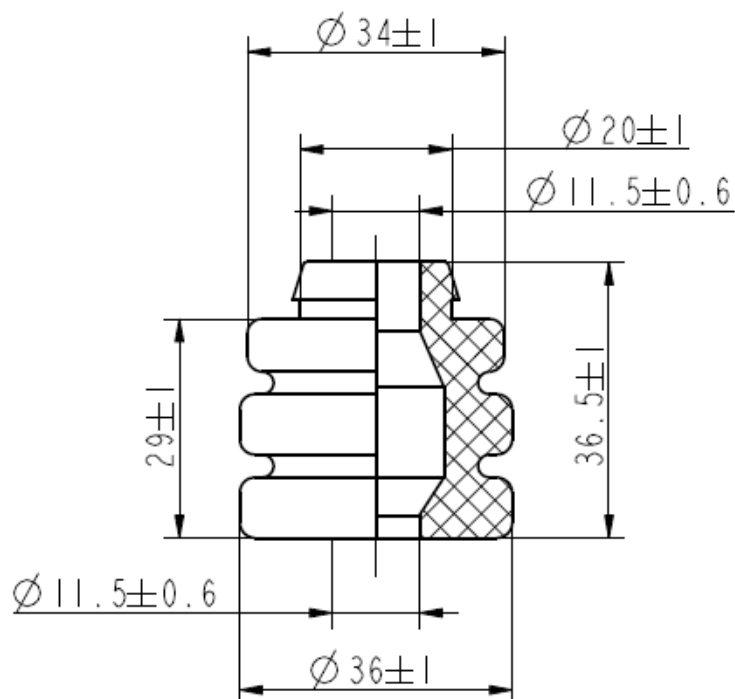

注释

NOTES

材质：三元乙丙胶

MATERIAL: EPDM

硬度：HS=40±4

HARDNESS: HS=40±4

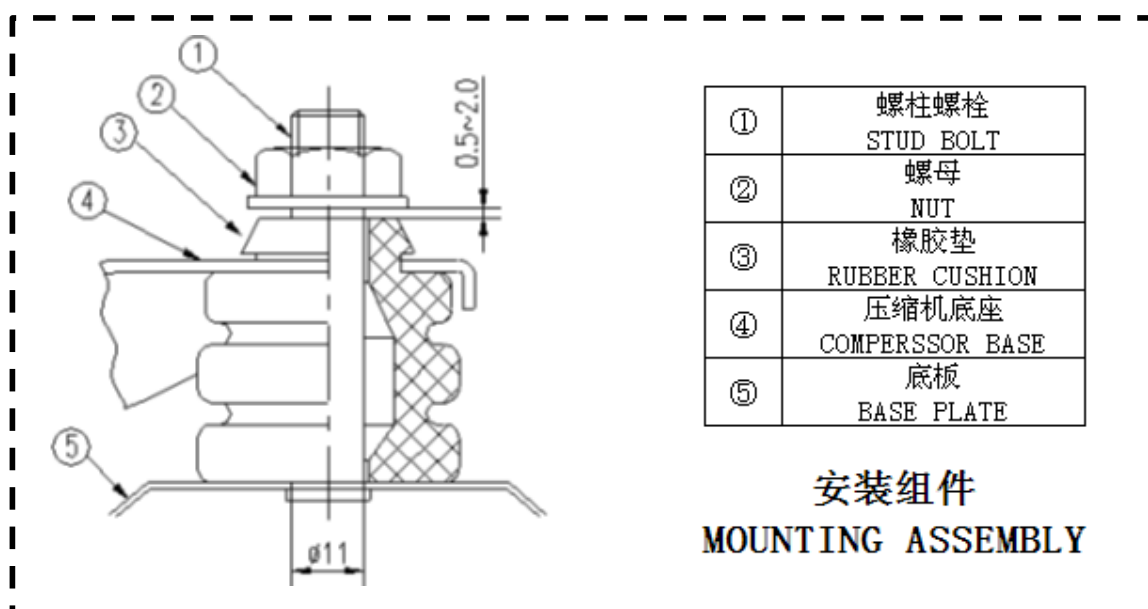

| | |
|---|--------------------------|
| ① | 螺柱螺栓 STUD BOLT |
| ② | 螺母 NUT |
| ③ | 橡胶垫 RUBBER CUSHION |
| ④ | 压缩机底座 COMPRESSOR BASE |
| ⑤ | 底板 BASE PLATE |

安装组件

MOUNTING ASSEMBLY

外形图 (COMPRESSOR DRAWING)

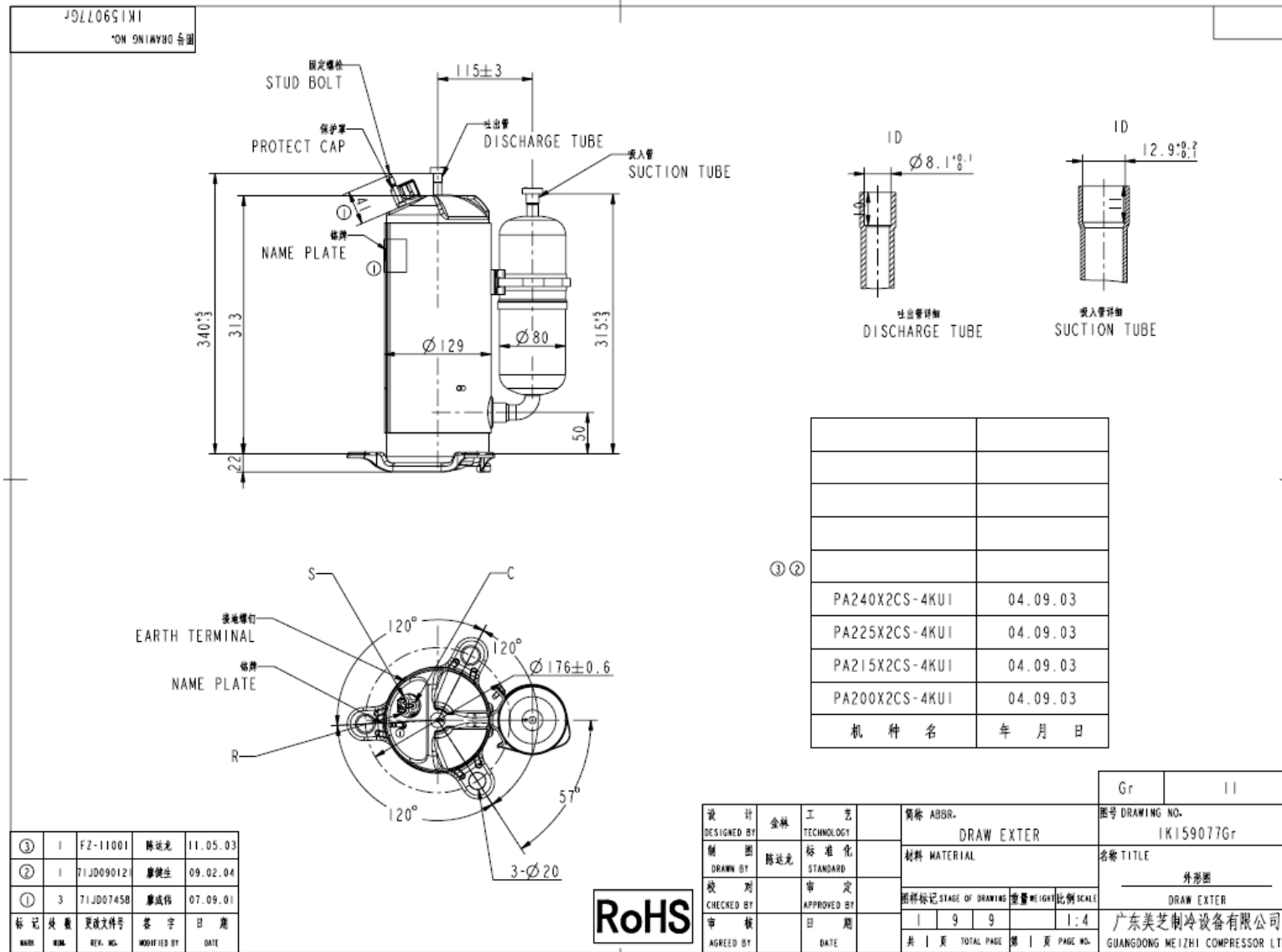

本文件含有美的集团的保密信息，禁止任何人未经授权以任何形式使用（包括但不限于全部或部分地泄露、复制、或散发）