

PERFORMANCE FOR COMPRESSOR

MODEL: GQR16K
9/10 PH, 50/60Hz, 194-242V

1、 APPLICATION

EVAPORATING TEMP RANGE	-40℃~0℃
COOLING TYPE	F
REFRIGERATION CONTROL	CAPILLARY
APPROVAL	CCC
VOLTAGE RANGE	220~240V
REFRIGERANT	R404A

2、 RATED PERFORMANCE AND TEST CONDITIONS

COOLING CAPACITY	865W)
INPUT POWER	710(W)
RATED CURRENT	4.44(A)
(EFFICIENCY) COP	1.21W/W)
ASHRAE TEST CONDITION	M/LBP
TEST POWER SOURCE	220-240V~50-60Hz 1PH
EVAPORATING TEMP	-23.3℃
CONDENSING TEMP	54.4℃
SUNCTION TEMP	32.2℃

压缩机特性规格书

PERFORMANCE FOR COMPRESSOR

MODEL: GQR16K

9/10 PH, 50/60Hz, 194-242V

SUBCOOLING TEMP	32.2°C
AMBIENT TEMP	32.2°C

3、MAIN STRUCTURE

COMPRESSOR TYPE	HERMTIC MOTOR-COMPRESSOR
PUMP TYPE	RECIPROCATING TYPE
DISPLACEMENT	16.15cm ³
OIL TYPE	RL46H
OIL CHARGE	400ml
PAINTING	BLACK PAINT,BAKED
NET WEIGHT	13.8Kg
ID OF SUCTION TUBE	Φ8.1±0.1
ID OF DISCHARGE TUBE	φ6.5±0.1
ID OF PROCESS TUBE	Φ8.1±0.1
RESIDUAL IMPURITIES	80mg MAX
RESIDUAL MOISTURE	100mg MAX

4、MOTOR

PERFORMANCE FOR COMPRESSOR

MODEL: GQR16K
9/10PH, 50/60Hz, 194-242V

STARTING TYPE	CSR
VOLTAGE RANGE	187~240V
INSULATION GRADE	B GRADE
LOCKED ROTOR	25.7A

5、 ELECTRICAL COMPONENTS

THERMAL PROTECTOR	
TYPE	GQR16K-MD/ B220-120
TRIP TEMP	120±5°C
RESET TEMP	43-61°C
(U.T.C) 75°C	6.03A
TRIP CURRENT) 25°C	22.0A
TRIP TIME	7-16S
STARTING RELAY	
TYPE	GQR16K-MD / QLZ-13.2A
RESISTANCE	/
RESET TIME	/
RUNNING CAPACITOR	
TYPE	/

CAPACITY VALUE)25°C	10uf
STARTING CAPACITOR	
TYPE	/
APACITY VALUE)25°C	80 μ F 330VAC 50/60Hz

LIST OF COMPRESSOR & ACCESSORIES

MODEL: GQR16K
9/10 PH, 50/60Hz, 194-242V

6、 ACCESSORIES LIST

NAME	DTSCRIPTION	QTY
THERMAL PROTECTOR	GQR16K-MD/ B220-120	1
STARTING RELAY	GQR16K-MD / QLZ-13.2A	1
RUNNING CAPACITOR	10uf	1
STARTING CAPACITOR	80 μ F	1
ELECTRICAL COVER		1
COVER CLAMP		1
RUBBER GROMMET		4
BUSHING		4

7、 ELECTRICAL WIRING DIAGRAM

DIMENSIONS FOR COMPRESSOR

MODEL: GQR16K
9/10PH, 50/60Hz, 194-242V

Height value of compressor: $H=220.5 \pm 2\text{mm}$

9、(MOUNTING DIAGRAM FOR COMPRESSOR

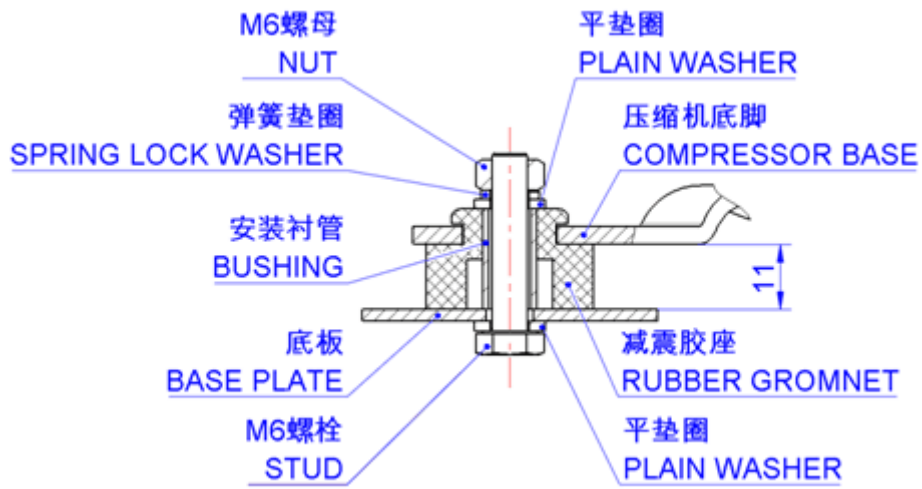

(MOUNTING TYPE) :(1)

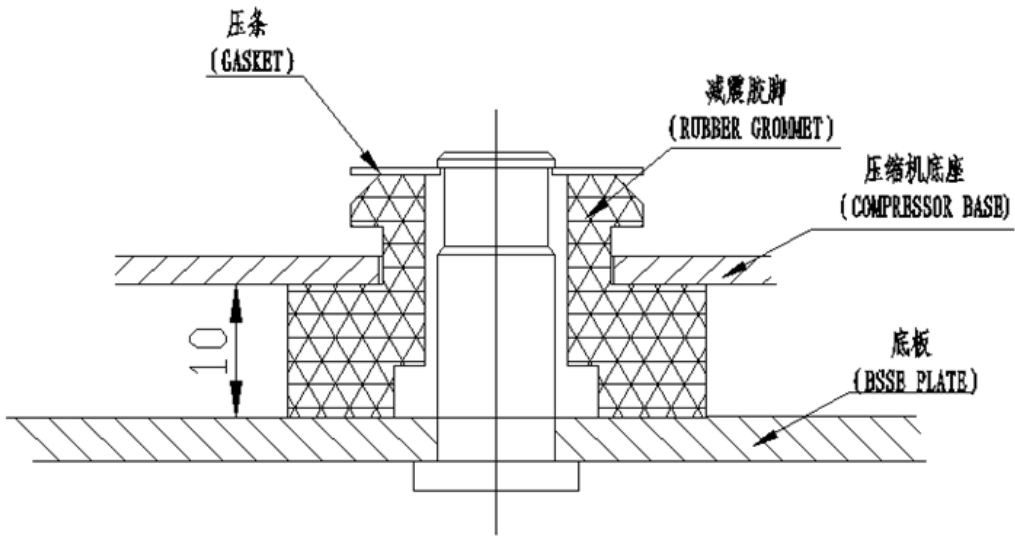

(MOUNTING TYPE) :(2)

TRANSPORTATION FOR COMPRESSOR

MODEL: GQR16K
9/10 PH, 50/60Hz, 194-242V

10、 TRANSPORTATION FOR COMPRESSOR

Packing type	Disposable
Transport	Train, bus, vessel
Stacking layers	not more than two layers
Model	GQR16K
Moving	Keep the compressor normal and vertical status