



PERFORMANCE FOR COMPRESSOR

MODEL: QDZH50G

12/24V (DC)

1、APPLICATION

EVAPORATING TEMP RANGE	-35~-15℃
COOLING TYPE	F
REFRIGERATION CONTROL	CAPILLARY
APPROVAL	CE
VOLTAGE RANGE	12/24 (DC)
REFRIGERANT	R134a

2、RATED PERFORMANCE AND TEST CONDITIONS

ROTATE SPEED	COOLING CAPACITY	EFFICIENCY: COP
2000 (rpm)	100.0 (W)	1.2 (W/W)
2500 (rpm)	130.0 (W)	1.2 (W/W)
3000 (rpm)	160.0 (W)	1.2 (W/W)
3500 (rpm)	180.0 (W)	1.2 (W/W)
ASHRAE TEST CONDITION	LBP	
TEST POWER SOURCE	12/24 (DC)	
EVAPORATING TEMP	-23.3℃	
CONDENSING TEMP	54.4℃	
SUNCTION TEMP	32.2℃	
SUBCOOLING TEMP	32.2℃	
AMBIENT TEMP	32.2℃	



PERFORMANCE FOR COMPRESSOR

MODEL: QDZH50G
12/24V (DC)

3、 MAIN STRUCTURE

COMPRESSOR TYPE	HERMTIC MOTOR-COMPRESSOR
PUMP TYPE	RECIPROCATING TYPE
OIL TYPE	22#
OIL CHARGE	180ml
PAINTING	BLACK PAINT,BAKED
NET WEIGHT	6.2Kg
ID OF SUCTION TUBE	Ø6.2±0.1
ID OF DISCHARGE TUBE	Ø5.1±0.1
ID OF PROCESS TUBE	Ø6.2±0.1
RESIDUAL IMPURITIES	80mg MAX
RESIDUAL MOISTURE	100mg MAX

4、 MOTOR

STARTING TYPE	MK-75-12/24V
VOLTAGE RANGE	12/24V
INSULATION GRADE	B GRADE



PERFORMANCE FOR COMPRESSOR

MODEL: QDZH50G
12/24V (DC)

5、 ELECTRICAL COMPONENTS

MOTOR SPEED	RESISTANCE(8)	C/T CURRENT
2000 (rpm)	0 (Ω)	0.87~1.02 (mA)
2100 (rpm)	51 (Ω)	1.02~1.17 (mA)
2200 (rpm)	100 (Ω)	1.17~1.32 (mA)
2300 (rpm)	150 (Ω)	1.32~1.48 (mA)
2400 (rpm)	200 (Ω)	1.48~1.63 (mA)
2500 (rpm)	277 (Ω)	1.63~1.78 (mA)
2600 (rpm)	330 (Ω)	1.78~1.93 (mA)
2700 (rpm)	400 (Ω)	1.93~2.08 (mA)
2800 (rpm)	490 (Ω)	2.08~2.24 (mA)
2900 (rpm)	586 (Ω)	2.24~2.39 (mA)
3000 (rpm)	692 (Ω)	2.39~2.54 (mA)
3100 (rpm)	816 (Ω)	2.54~2.69 (mA)
3200 (rpm)	963 (Ω)	2.69~2.84 (mA)
3300 (rpm)	1137 (Ω)	2.84~3.00 (mA)
3400 (rpm)	1331 (Ω)	3.00~3.15 (mA)
3500 (rpm)	1523 (Ω)	3.15~3.61 (mA)
STOP	>3000 (Ω)	3.61~5.00 (mA)

LIST OF COMPRESSOR & ACCESSORIES

MODEL: QDZH50G
12/24V (DC)

6、ACCESSORIES LIST

NAME	DESCRIPTION	QTY
CONTROLLER	MK-75-12/24V MK-QDZH75G	1
RUBBER GROMMET		4
BUSHING		4

7、ELECTRICAL WIRING DIAGRAM

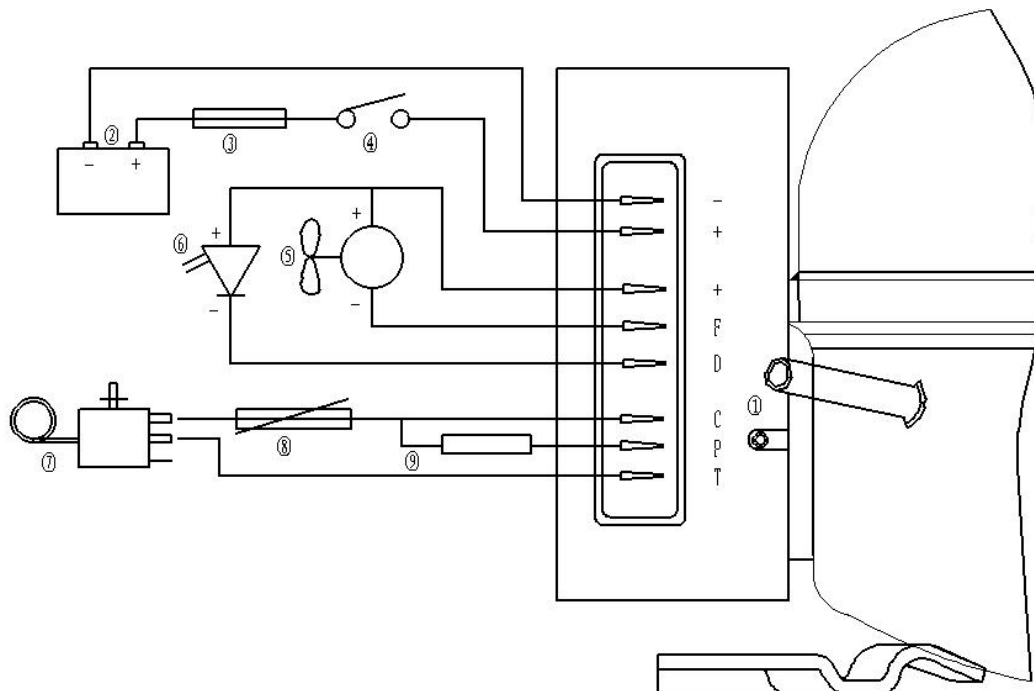



DIMENSIONS FOR COMPRESSOR

MODEL: QDZH50G
12/24V (DC)

8、 DIMENSIONS FOR COMPRESSOR:

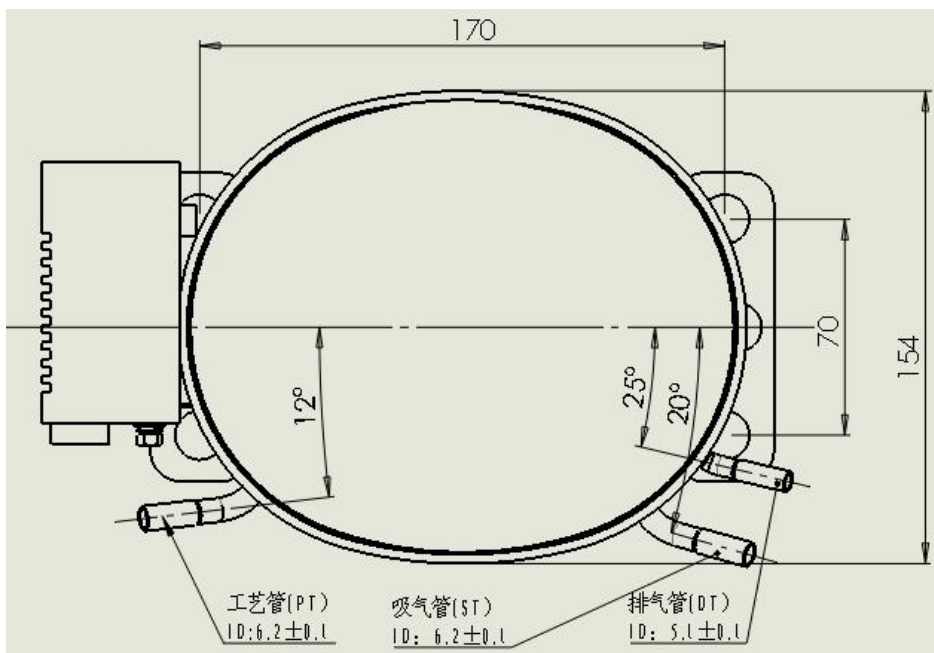
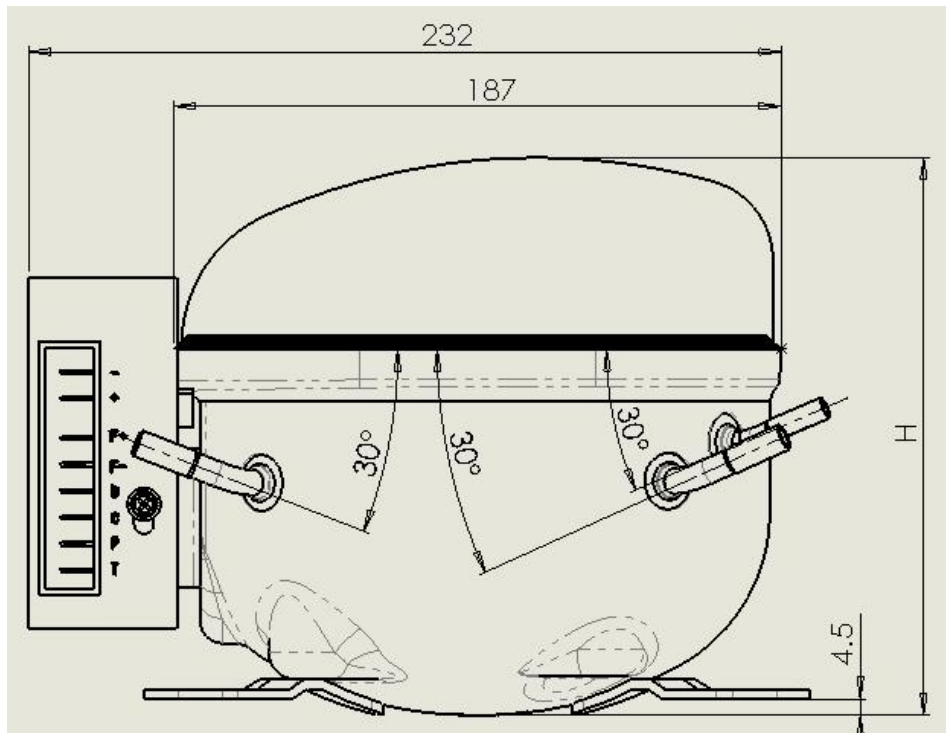

Height value of compressor: $H=162 \pm 2\text{mm}$.

MOUNTING DIAGRAM FOR COMPRESSOR

MODEL: QDZH50G

12/24V (DC)

9、MOUNTING DIAGRAM FOR COMPRESSOR

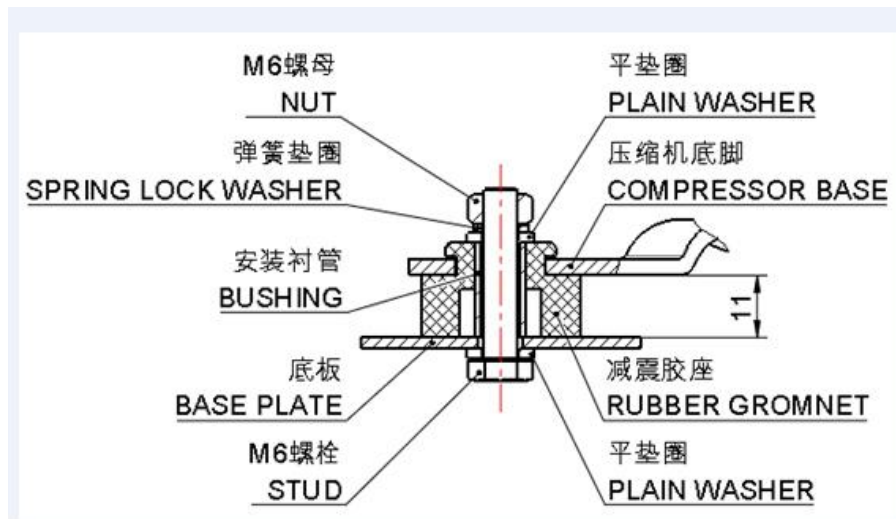

MOUNTING TYPE:(1)

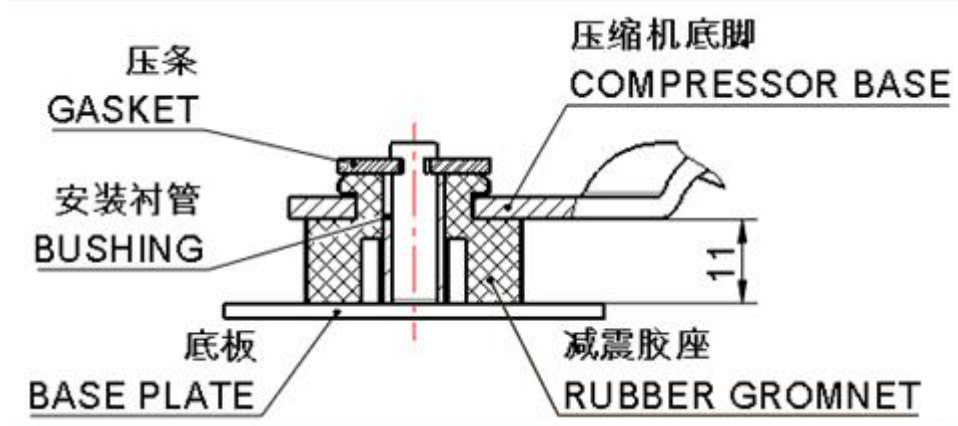

MOUNTING TYPE:(2)



TRANSPORTATION FOR COMPRESSOR

MODEL: QDZH50G

12/24V (DC)

10、TRANSPORTATION FOR COMPRESSOR

Packing type	Disposable
Transport	Train, bus, vessel
Stacking layers	not more than two layers
Model	QDZH50G
Moving	Keep the compressor normal and vertical status