



## PERFORMANCE FOR COMPRESSOR

MODEL: QDZY75G

12/24V (DC)

### 1、 APPLICATION

EVAPORATING TEMP RANGE	-35~-15℃
COOLING TYPE	F
REFRIGERATION CONTROL	CAPILLARY
APPROVAL	
VOLTAGE RANGE	12/24 (DC)
REFRIGERANT	R600a

### 2、 RATED PERFORMANCE AND TEST CONDITIONS

ROTATE SPEED	COOLING CAPACITY	EFFICIENCY: COP
2000 (rpm)	85 (W)	1.15 (W/W)
2500 (rpm)	108 (W)	1.25 (W/W)
3000 (rpm)	125 (W)	1.3 (W/W)
3500 (rpm)	145 (W)	1.3 (W/W)
ASHRAE TEST CONDITION	LBP	
TEST POWER SOURCE	12/24 (DC)	
EVAPORATING TEMP	-23.3℃	
CONDENSING TEMP	54.4℃	
SUNCTION TEMP	32.2℃	
SUBCOOLING TEMP	32.2℃	
AMBIENT TEMP	32.2℃	



## PERFORMANCE FOR COMPRESSOR

MODEL: QDZY75G

12/24V (DC)

### 3、MAIN STRUCTURE

COMPRESSOR TYPE	HERMTIC MOTOR-COMPRESSOR
PUMP TYPE	RECIPROCATING TYPE
OIL TYPE	L-DRB/A10
OIL CHARGE	130ml
PAINTING	BLACK PAINT,BAKED
NET WEIGHT	4.4Kg
ID OF SUCTION TUBE	Ø6.2±0.1
ID OF DISCHARGE TUBE	Ø5.1±0.1
ID OF PROCESS TUBE	Ø6.2±0.1
RESIDUAL IMPURITIES	80mg MAX
RESIDUAL MOISTURE	100mg MAX

### 4、MOTOR

STARTING TYPE	L-DC65-12/24
VOLTAGE RANGE	12/24V-
INSULATION GRADE	E GRADE



## PERFORMANCE FOR COMPRESSOR

MODEL: QDZY75G

12/24V (DC)

### 5、 ELECTRICAL COMPONENTS

MOTOR SPEED	RESISTANCE(8)	C/T CURRENT
2000 (rpm)	0 ( $\Omega$ )	0.87~1.02 (mA)
2100 (rpm)	51 ( $\Omega$ )	1.02~1.17 (mA)
2200 (rpm)	100 ( $\Omega$ )	1.17~1.32 (mA)
2300 (rpm)	150 ( $\Omega$ )	1.32~1.48 (mA)
2400 (rpm)	200 ( $\Omega$ )	1.48~1.63 (mA)
2500 (rpm)	277 ( $\Omega$ )	1.63~1.78 (mA)
2600 (rpm)	330 ( $\Omega$ )	1.78~1.93 (mA)
2700 (rpm)	400 ( $\Omega$ )	1.93~2.08 (mA)
2800 (rpm)	490 ( $\Omega$ )	2.08~2.24 (mA)
2900 (rpm)	586 ( $\Omega$ )	2.24~2.39 (mA)
3000 (rpm)	692 ( $\Omega$ )	2.39~2.54 (mA)
3100 (rpm)	816 ( $\Omega$ )	2.54~2.69 (mA)
3200 (rpm)	963 ( $\Omega$ )	2.69~2.84 (mA)
3300 (rpm)	1137 ( $\Omega$ )	2.84~3.00 (mA)
3400 (rpm)	1331 ( $\Omega$ )	3.00~3.15 (mA)
3500 (rpm)	1523 ( $\Omega$ )	3.15~3.61 (mA)
STOP	>3000 ( $\Omega$ )	3.61~5.00 (mA)

## LIST OF COMPRESSOR & ACCESSORIES

MODEL: QDZY75G

12/24V (DC)

### 6、ACCESSORIES LIST

NAME	DTSCRIPTION	QTY
CONTROLLER	L-DC65-12/24	1
RUBBER GROMMET		4
BUSHING		4

### 7、ELECTRICAL WIRING DIAGRAM

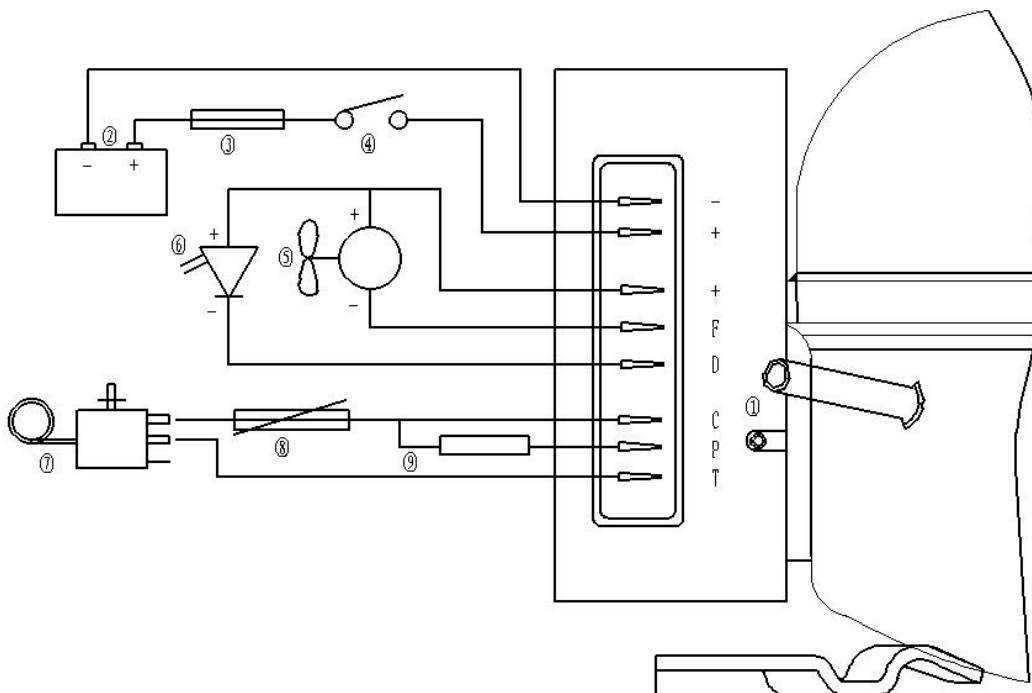

## DIMENSIONS FOR COMPRESSOR

MODEL: QDZY75G

12/24V (DC)

### 8、DIMENSIONS FOR COMPRESSOR:

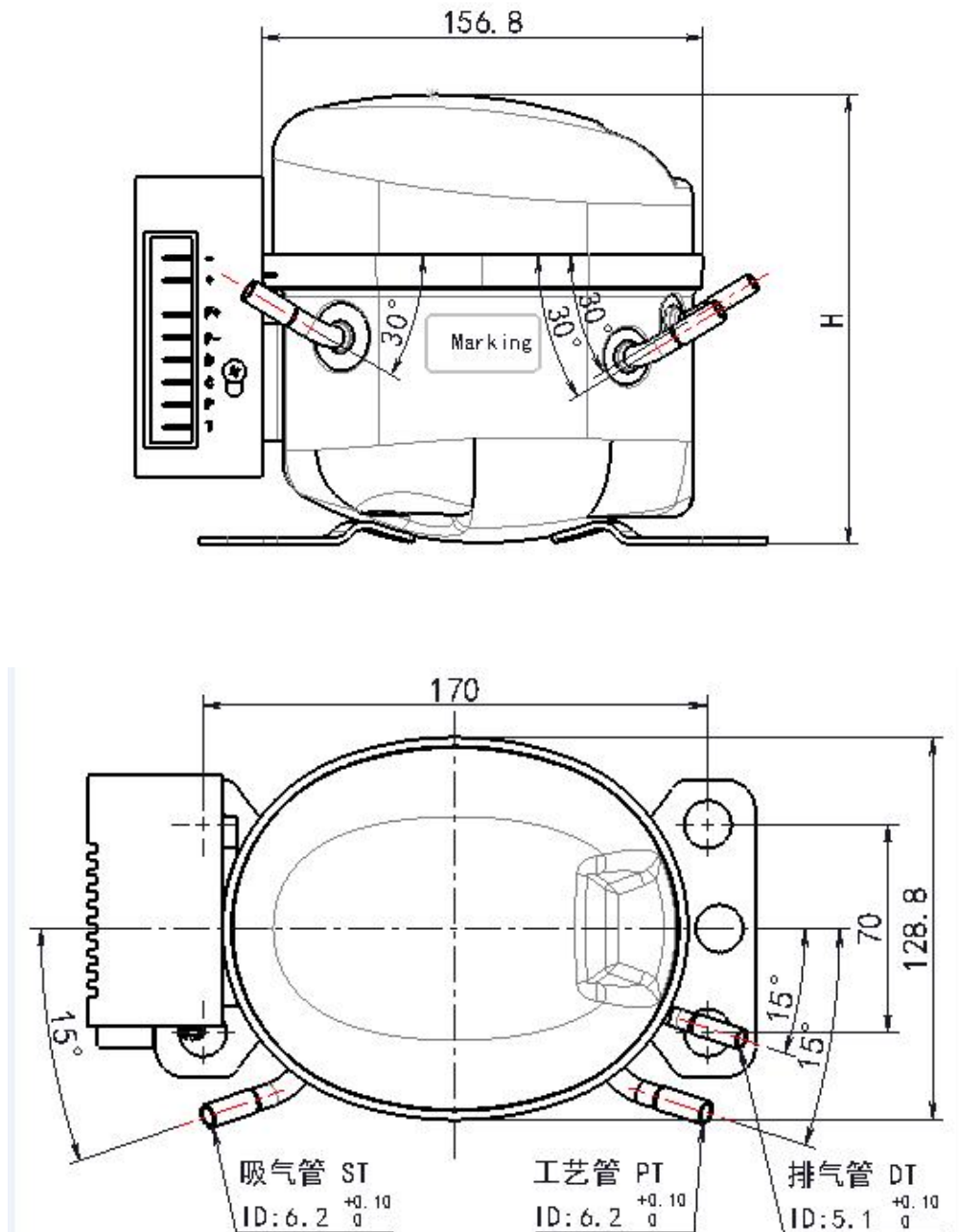

Height value of compressor:  $H=156.5 \pm 2\text{mm}$ .

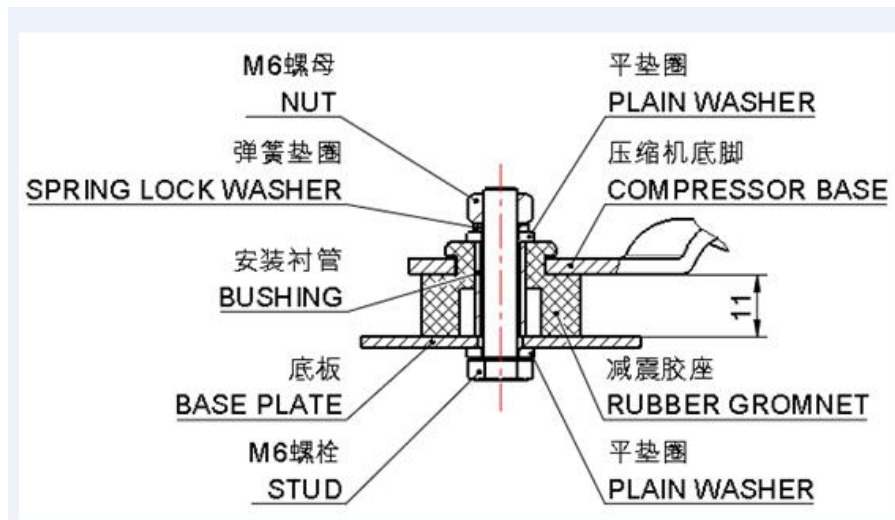
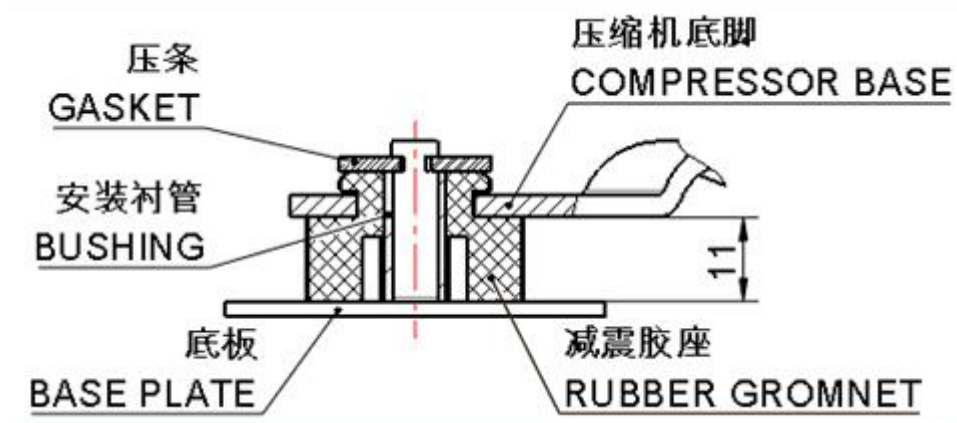
**MOUNTING DIAGRAM FOR COMPRESSOR**
**MODEL: QDZY75G**
**12/24V (DC)**
**9、MOUNTING DIAGRAM FOR COMPRESSOR**

**MOUNTING TYPE:(1)**

**MOUNTING TYPE:(2)**



TRANSPORTATION FOR COMPRESSOR

MODEL: QDZY75G

12/24V (DC)

10、TRANSPORTATION FOR COMPRESSOR

Packing type	Disposable
Transport	Train, bus, vessel
Stacking layers	not more than two layers
Model	QDZY75G
Moving	Keep the compressor normal and vertical status